



ELECTRICAL POWER

FUSES, FUSEGEAR,
& FUSE SYSTEMS

POWER DISTRIBUTION

LOW VOLTAGE
DISCONNECT SWITCHES

ENGINEERED SOLUTIONS

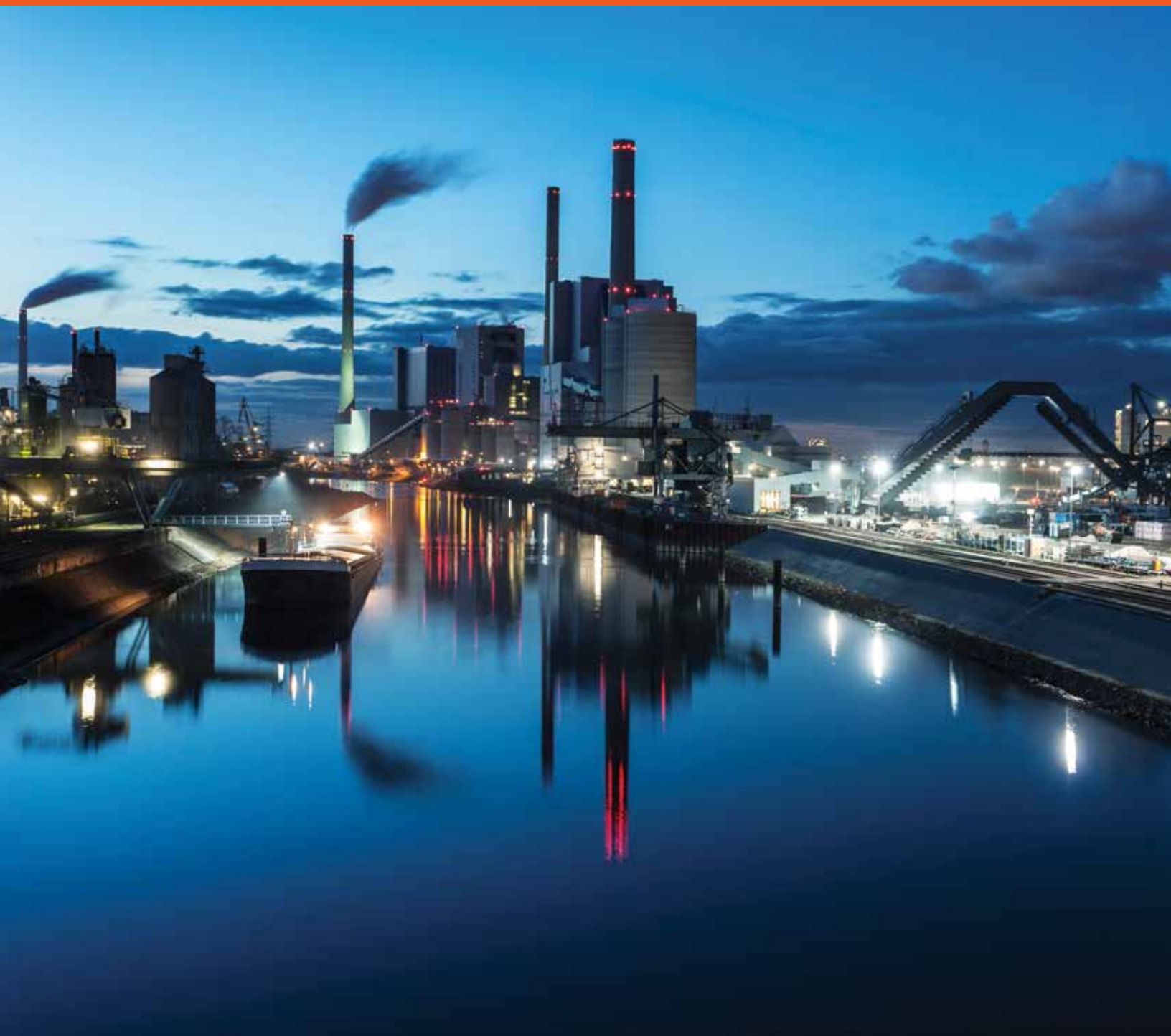



ELECTRICAL PROTECTION & CONTROL

Differentiating global platform of electrical power components for power distribution and power control applications

FIVE GLOBAL PRODUCT LINES

UL/CSA Fuses and Fusegear



Class RK1



Class RK5



High-speed Fuses



Class CC-Midget



Class J



Medium Voltage



PV/Solar Fuses

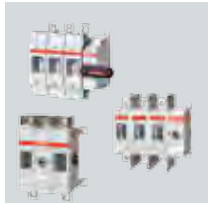

Low Voltage Disconnect Switches



Power Distribution Blocks

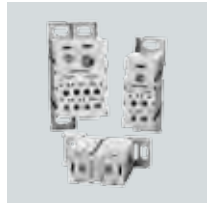

Finger Safe Power Distribution Blocks



UL/CSA Modular Fuse Holders



UL/CSA Fuse Bases

IEC Fuses and Fusegear

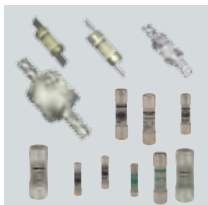

Cylindrical FR and BS88



NH PV/Solar Fuses



DIN and French Standard High Voltage Fuses

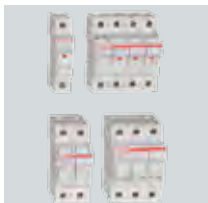

Cylindrical Fuse Holders



DIN D0 Fusegear



NH Fuse Switch Disconnectors

Surge Protection



UL SPD



Outdoor LED Lighting Protection



Modular and Pluggable UL SPD



Thermally Protected MOV (TPMOV)



SOLUTIONS FOR POWER MANAGEMENT

Advanced passive components for converter/inverter and battery storage power management

THREE GLOBAL PRODUCT LINES

Power Transfer for Rail Vehicles



Earth Return Current Units



Fuse Box



3rd Rail Current Collector Device



Surge Arresters

High Power Switches and Contactors



HAS



HSE, HSD, HSLT



Bar Contactors



NOR-R Range

Bus Bars



Concentrated package for traction drive



Power distribution system for frequency inverter



Flexible package for variable frequency drive

Cooling Solutions



Air cooling



Liquid Cooling Cold Plate



Stand-alone Heatpipes

Overcurrent Protection for Semiconductors & Batteries; High Speed Fuses & Hybrid Devices



Cylindrical



Square Body



Round Body



High-performance fuses



NH



Xp-Xs

P
F

PF: UL/CSA Listed Power Fuses

Class L
 A4BQ..... PF 2
 A4BY..... PF 4
 A4BT..... PF 6

Class RK1
 A2D-R & A6D-R..... PF 8
 A2K-R & A6K-R..... PF 10

Class RK5
 TR-R & TRS-R..... PF 12
 TRS-RDC..... PF 14

Class J
 AJT..... PF 16
 AJT Reducer Fuses..... PF 28
 HSJ..... PF 20
 A4J..... PF 22

Class CC
 ATDR..... PF 24
 ATQR..... PF 26
 ATMR..... PF 28

Class G
 AG..... PF 29

Class K-5
 OT/OTN/OTS..... PF 30

Class T
 A3T & A6T..... PF 32

Canadian Fuses
 Class C..... PF 34
 Class H NRN/NRS..... PF 36
 Class H CRN/CRS..... PF 37

Accessories
 Fuse Pullers/Clip Clamps..... PF 38

M
F

MF: Midget, PC Mount & Miniature Fuses

Midget
 ATQ Time-Delay..... MF 2
 ATM Fast-Acting..... MF 3
 TRM Time-Delay..... MF 4
 OTM Fast-Acting..... MF 5
 DCT Special Purpose..... MF 6
 FSM Multi-Meter Fuse..... MF 7
 GGU Fast-Acting..... MF 8
 GFN Indicating Time-Delay..... MF 9
 SBS Fast-Acting..... MF 10

PC Mount
 PCF, PCS, PCT..... MF 11

M
V

Miniature
 GSA/GSA-V..... MF 15
 GDL/GDL-V..... MF 16
 GGC/GGC-V, GGM/GGM-V..... MF 17
 GGA/GGA-V, GSC/GSC-V..... MF 18
 GSB/GSB-V, GDG/GDG-V..... MF 19
 GSD/GSD-V, GSF/GSF-V..... MF 20
 GGX, GAB..... MF 21
 SMG/SMG-V, STG/STG-V..... MF 22
 MRF, MRT Radial Lead Micro Fuses..... MF 23
 SFRT, SFRB, SFRG, FSFE, SFRU In-Line Fuse Holders..... MF 24
 SLR, SMF, SHR In-Line Fuses and Holders..... MF 25

S
P

MV: Medium Voltage Fuses

Transformer Protection
 Amp-Trap® CS-3 and 9F60/9F62 Series..... MV 2
 Amp-Trap® & 9F62 Bolt-In Series..... MV 12
 Amp-Trap® CL-14 Series..... MV 16

Motor Protection
 Amp-Trap® & 9F60 Series..... MV 20
 Amp-Trap® Bolt-in Series..... MV 26
 Amp-Trap® DIN-style Series..... MV 29

Potential Transformer Protection
 Amp-Trap® & 9F60 Series PT Fuses..... MV 31

Capacitor Protection
 Amp-Trap® & 9F60 Series..... MV 35

F
B

P
D

SP: Special Purpose

EV/Automotive
 M-fuse Battery Module Fuses..... SP 2
 MEV55 Battery Pack Fuses..... SP 5
 MEV70 Battery Pack Fuses..... SP 9
 MEV100 Battery Pack Fuses..... SP 12
 Xp Series..... SP 15
 Xs EV Series..... SP 17
 Automotive Fuses & Holders..... SP 21
 Forklift Truck Fuses..... SP 24

Cable Protectors
 CP 600V Cable Protectors..... SP 26
 2CL 250V Cable Protectors..... SP 34

DC Fuses
 A60C Capacitor Fuses..... SP 35
 A4BX Welder Protectors..... SP 36
 A2Y & A6Y Form 600 Fuses..... SP 37

D
S

E
S

A
P

Photovoltaic Fuses

HP6M PV Fuses SP 39
 HP10M PV Fuses SP 41
 Dual HP10M Fuses SP 43
 HP15M PV Fuses SP 44
 Dual HP15M Fuses SP 46
 HP15G PV Fuses SP 47
 HP6J PV Fuses SP 49
 HP10J PV Fuses SP 51
 HP10NH PV Fuses SP 55
 HP12NH PV Fuses SP 57
 HP15NH PV Fuses SP 59

FB: Fuse Blocks & Holders

UltraSafe™

USCC & USM FB 2
 USBB Bus Bar FB 4
 USGCC & USGM FB 6
 USFM FB 8
 US3J & US6J FB 10
 US14 & US22 FB 12

Open Style

Class J & SJ Series FB 16
 Midget/Class CC FB 20
 Class H, K & R FB 22
 Class T FB 29
 Class G FB 34
 FEB/FEC/FEX/FEY FB 36

Photovoltaic

HPJ Class J FB 40
 US15M1HEL FB 42
 HP15FHM32 FB 43
 HPBB 1000V DC Size NH FB 44

Medium Voltage

Type EK 9F61 Series Fuse Holders and Clips FB 45
 CL-14 Fuses Clip-Lock Clips FB 54

Semiconductor

P243/P266/P292 FB 55
 1SC/1MSC Modular FB 56
 703, U705, U710 Series FB 57
 PS20x127 Ferrule FB 59

Miniature/Panel Mount

Miniature Fuse Blocks FB 61
 GPM Series Panel Mount FB 62

Covers/Clips

DFC Dead Front Fuse Covers FB 69
 DFC3M/DFC3LP/DRM Fuse Block Accessories FB 71
 Ferrule Fuse Clips/PC BoardMount Fuse Clips FB 72

PD: Power Distribution Blocks

Finger-Safe / FSPDB Series PD 2
 MPDB Open-Style PDBs PD 4
 MPDB62-MPDB63 (Mini) Open-Style PDBs PD 6
 MPDB66-MPDB67 (Intermediate) Open-Style PDBs PD 7
 MPDB68-MPDB69 (Large) Open-Style PDBs PD 9
 MPDB Double-Wide Open-Style PDBs PD 11
 Dimensions PD 12

DS: Disconnect Switches

UL 508 Non-Fusible Disconnect Switches DS 2
 UL 98 Non-Fusible Disconnect Switches DS 5
 UL 98 Fusible Disconnect Switches DS 10
 PV-Rated UL and IEC Disconnect Switches DS 15
 Enclosed Disconnect Switches DS 19

ES: Engineered Solutions

Fused Coordination Panelboards ES 2
 Fusible Shunt Trip Switch ES 4

AP: Application Information

Definitions AP 2
 Fuse Descriptions AP 4
 Fuse Construction & Operation AP 4
 How to Read a Time Current Curve AP 5
 Low Voltage Motor Protection AP 6
 Transformer Protection AP 11
 General AP 11
 Low Voltage Primary Protection AP 11
 Primary/Secondary Fuses for LV Transformers AP 12
 Control Transformers AP 13
 MV Transformers AP 14
 Let-Thru Current & I²T AP 20
 Fuse Let-Thru Current Tables AP 21
 Capacitor Protection AP 27
 Cable Protection AP 29
 Motor Starter General Info AP 30
 Auxiliary Contacts AP 31
 Selectivity Between Fuses AP 32
 Short Circuit Calculations AP 33
 Short Circuit Rating AP 34
 11 Reasons for Using Current-Limiting Fuses AP 34
 Fuse Obsolescence AP 35
 Suggested Fuse Specifications AP 36

IN: Index



Keeping industry safe with electrical protection products that mitigate arc flash hazards

It's your responsibility to protect your people and equipment. The explosive energies reached during an arc flash – intense heat, thermoacoustic shock wave, molten metal, shrapnel, blinding light, toxic smoke – can cause severe, often fatal, injuries to workers even several feet away. It's imperative that your electrical systems are protected – and Mersen electrical protection components can provide the peace of mind you need to keep your employees and equipment safe.

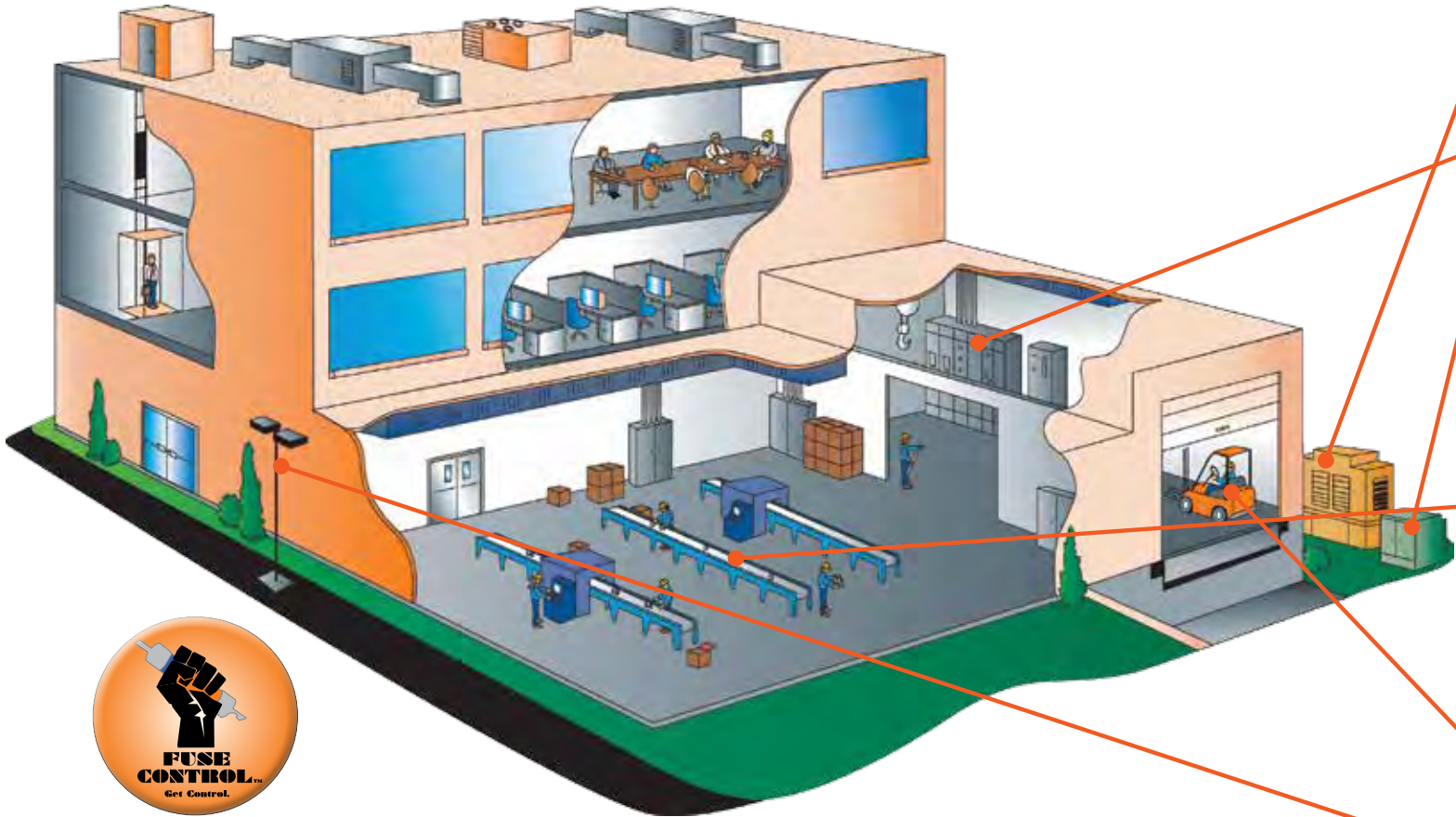

Fuse Control™

Mersen's **Fuse Control program** is a powerful combination of circuit protection products and services designed to help you **get control of your plant inventory, operating costs, code compliance, and workplace safety.**

Developed by Mersen and refined through extensive field research, Fuse Control will help you:

- Improve workplace safety

- Achieve electrical code compliance
- Reduce downtime associated with electrical failures
- Streamline inventory as much as 25% or more!
- Decrease operating costs

How can one program deliver such benefits? The key lies in consolidating your current inventory and installed overcurrent protective devices to one fuse line - Mersen's innovative Amp-Trap 2000® fuse family.

Amp-Trap 2000 fuses out-perform traditional fuses, opening in less than one-quarter cycle at fault currents up to 300kA, and minimize the let-through currents and energies that flow downstream during faults.

Order Fuse Control and receive a FREE Fuse Inventory Audit & Analysis. Take action today to get control of your inventory, contact a Mersen Sales Representative to initiate your Fuse Control program.

DISTRIBUTION NETWORK/BACK-UP GENERATOR

Class J Fuses



Medium Voltage Fuses



Cable Protectors



SWITCHGEAR/MOTOR CONTROL

Class L Fuses



Class J Fuses



Class T Fuses

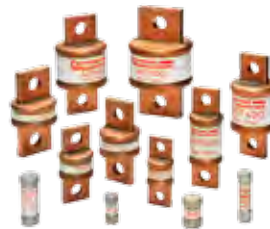

Surge Protective Devices



INDUSTRIAL CONTROLS

Class CC Fuses



UltraSafe™ Fuse Holders



Class J, RK1, T Fuses



Surge Protective Devices



SPECIALTY PRODUCTS

In-Line Fuse Holders



Forklift Truck Fuses



Surge Protective Devices



High Speed Fuses and Holders



Mersen electrical components protect your buildings from the ground up

Count on Mersen to provide the electrical protection components that are integral to safe operation of your building's electrical systems. Whether it's a Fusible Shunt Trip Switch to safely disconnect circuits during an emergency, fuses with high interrupting ratings, or surge protection to protect from overcurrent events originating inside or outside your building, Mersen has the products you need to keep your systems safe.

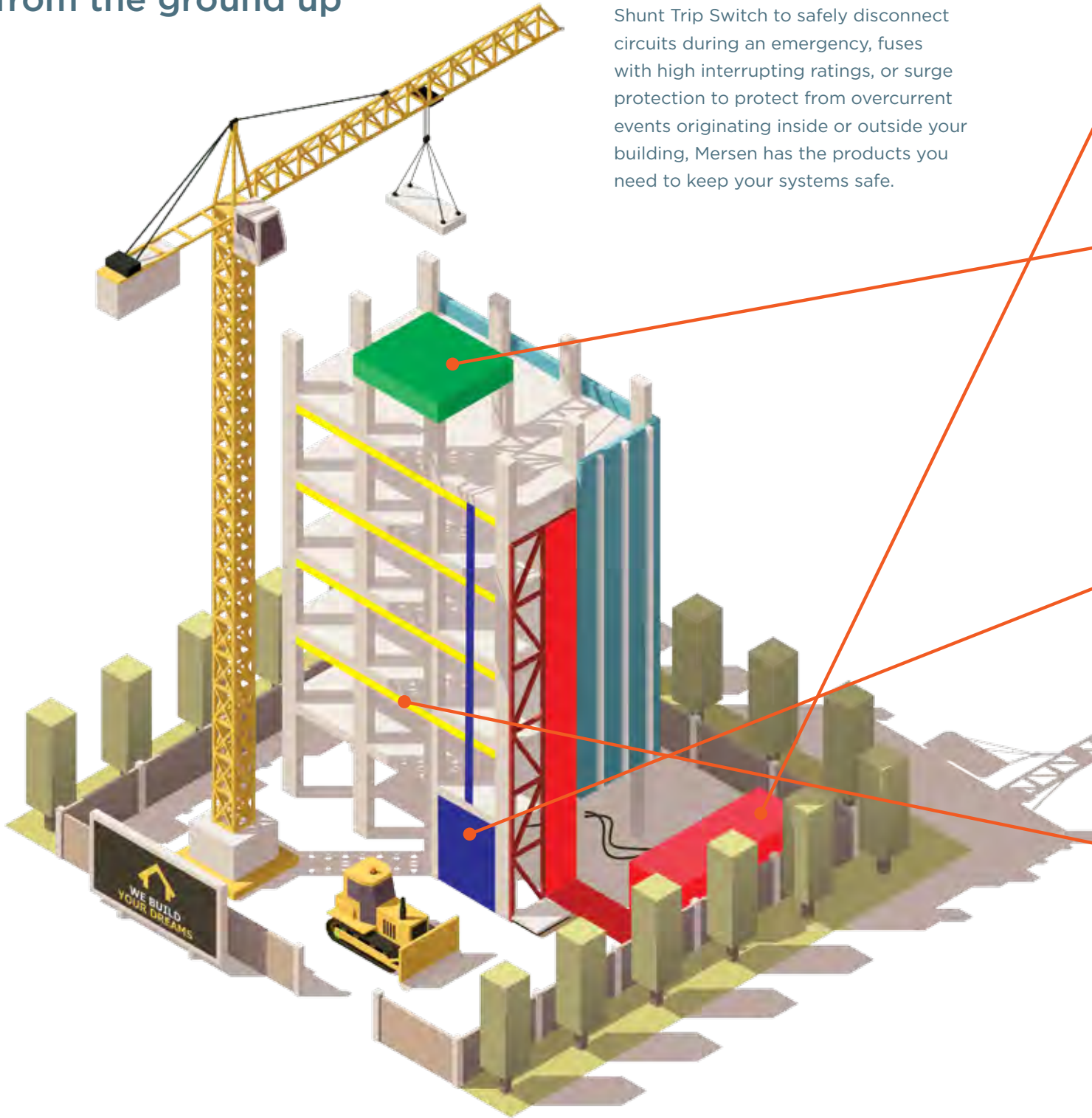

DISTRIBUTION NETWORK/BACK-UP GENERATOR

Medium Voltage Fuses



Class L Fuses



Surge Protective Devices



Fused Coordination
Panelboard



HVAC (HEATING, VENTILATION, AND AIR CONDITIONING)

Class J Fuses



Class CC Fuses



UltraSafe™ Fuse Holders



Surge Protective Devices



ELEVATOR/PEOPLE MOVER

Fusible Shunt Trip Switch



Class J Fuses



Class CC Fuses



Fused Coordination
Panelboard



DATA/LIGHTING CONTROL

Surge Protective Devices



Class CC Fuses



Class J Fuses



UltraSafe Fuse Holders



Protect your solar power investment with components specifically designed for PV applications

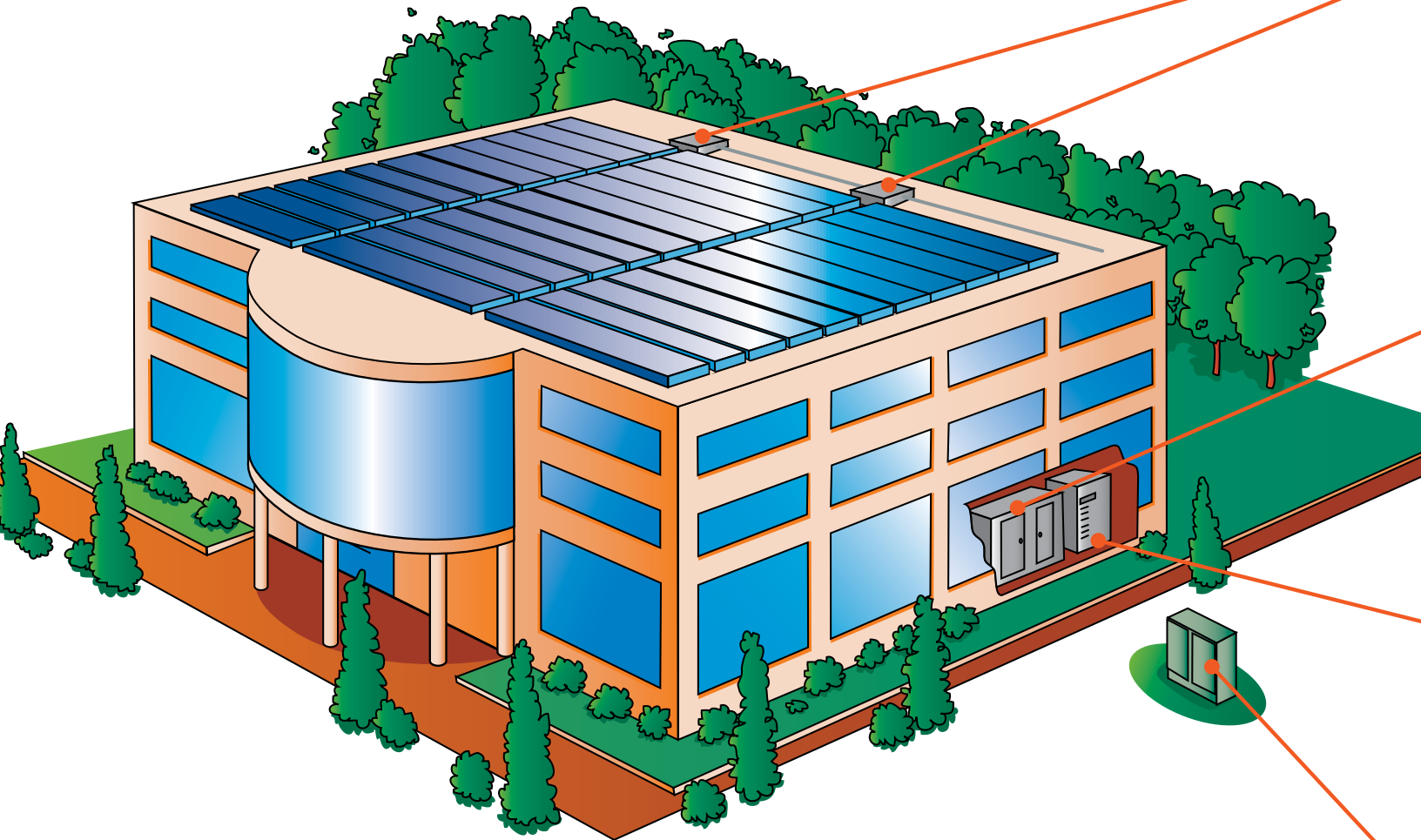

Residential 5 to 36kW

Mersen is a trusted partner of electrical equipment distributors and played a leadership role in solar power circuit protection long before the boom reached the residential market, i.e. for private homes, small apartment buildings and farm buildings.



Commercial and Industrial 36 to 250kW

The walls and roofs of buildings - office towers, factories, malls and warehouses - are among the preferred supports for solar power systems. Architects and developers have grasped the importance of this energy revolution, and more of them are recommending "green" solutions.

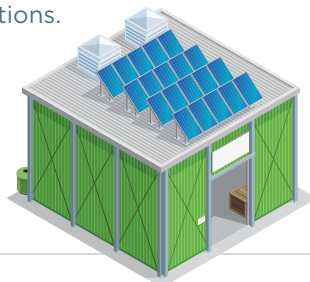

Utility and Solar Farm Over 250kW

In this type of application, the architecture is centered on an automatic monitoring and control system. Mersen caters to this critical market with electrical protection that safely and reliably protects the solar power investment.



STRING COMBINER BOX/ARRAY COMBINER BOX

Power Distribution Blocks



PV Fuses



Surge Protective Devices



Disconnect Switches



INVERTER

High-Speed Fuses & Fuse Holders



Power Distribution Blocks



Surge Protective Devices



Disconnect Switches



AC ELECTRICAL PANELBOARD

AJT Class J Fuses



Fuse Blocks



Surge Protective Devices



Disconnect Switches



UTILITY DISTRIBUTION NETWORK

Power Distribution Blocks



Surge Protective Devices



DC Protection



Surge Protective Devices



Components designed to protect your e-mobility power applications

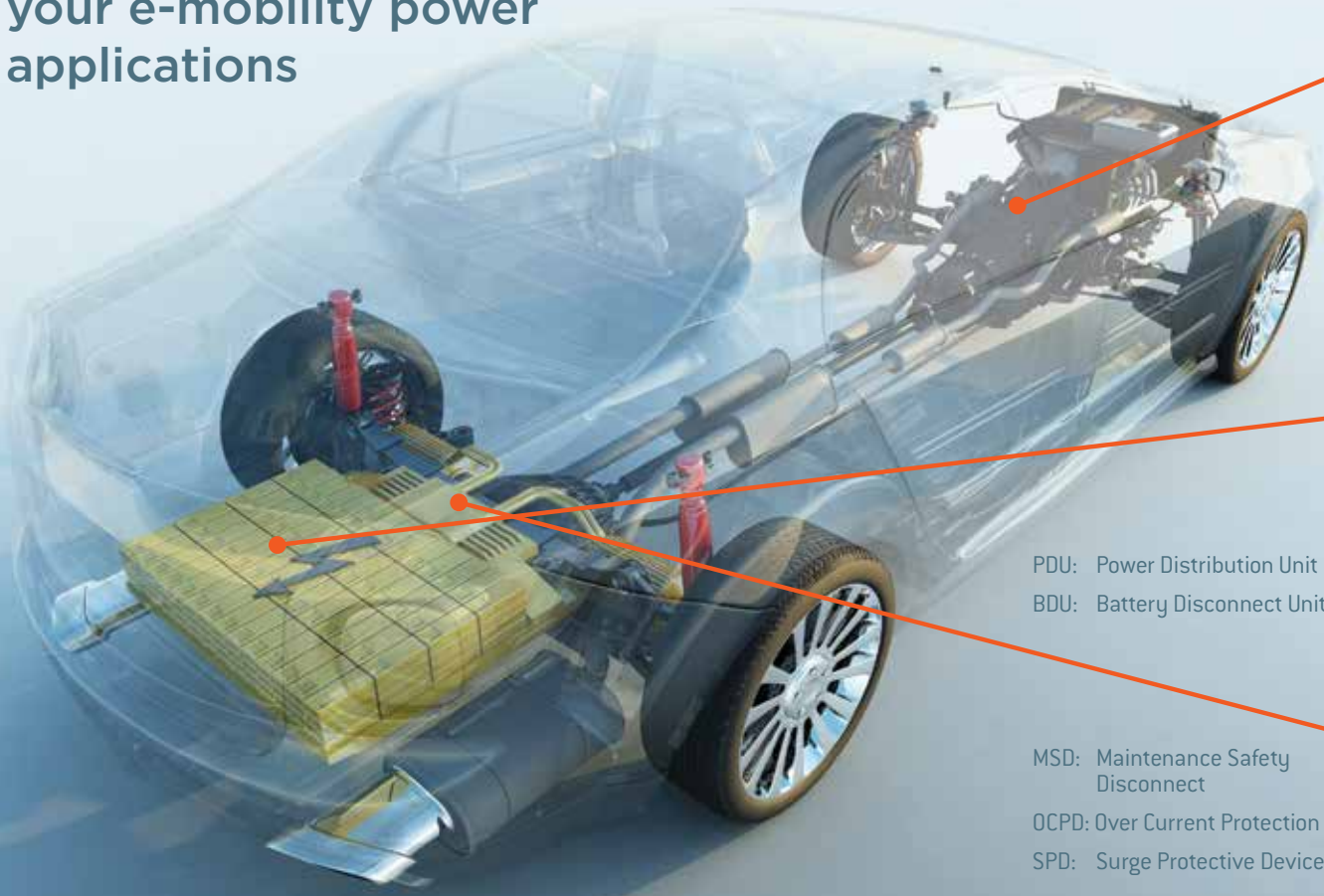

PDU: Power Distribution Unit
BDU: Battery Disconnect Unit

MSD: Maintenance Safety
Disconnect
OCPD: Over Current Protection Device
SPD: Surge Protective Device

With the continuous growth of DC battery-related applications on mobile platforms such as Electric Vehicles, comes the need for better operation, management, and protection of such loads.

Protection and Operation: Mersen has developed a broad range of DC Over Current Protection (OCP) devices, based upon incumbent DC fuse technology as well as disruptive hybrid approach (pyrotechnique and semiconductor based) designed to safely clear both high and low DC fault currents to help protect the vehicle electronics and occupants. Mersen Surge Protective Devices bring an additional layer of protection in case of overvoltage faults within the electrical systems. Hybrid DC Power Relays by Mersen can safely switch high DC voltage loads with superior cycling capability.

Management: Electric vehicle battery monitoring laminated bus bars from Mersen incorporate power and monitoring signals into a single compact and reliable platform, improving the safe operation of onboard batteries. Custom designed robust, reliable, and compact vacuum brazed cold plates are a must for cooling batteries as well as inverters in e-mobility power applications.



INVERTER/PDU

Cooling



Bus Bar



BATTERY MODULE

Cooling Plate



Monitoring Bus Bar



Module Fuse



BATTERY PACK/BDU/MSD

DC Battery Fuses



Hybrid Pyrotechnic OCPD



Hybrid DC Power Relay



CHARGING STATION

Surge Protective Devices
(SPDs)



AC and DC Fuses



Cooling



Bus Bar





Your problem: Today, you need a time-delay power fuse that can handle normal surges. Tomorrow, it's a power fuse with a high interrupting rating and the added security of rejection dimensions. The day after that, one of those economical one-time power fuses will do the trick. And what if you need to provide fuses for a global solution? Where do you turn?

Our solution: Mersen's comprehensive power fuse offering covers a complete range of applications and a complete range of circuit-protection needs. Whether it's the characteristics of our Tri-Onic® Time-delay fuses, the high current-limiting capacity of our original Amp-Trap® power fuses, the cost-efficient protection of our One-Time fuses, or any of our complete line of North American and European fuses, Mersen has the fuse you need.

Want more information fast? For more technical or application-specific information, please call our power fuse experts at 978-465-4853 or visit our website at ep.mersen.com.

UL/CSA Listed Power Fuses

THE MOST POPULAR
UL/CSA LISTED
POWER FUSES TO
MEET THE MOST
POPULAR PROTECTION
PRIORITIES

Class L

- A4BQ PF 2
- A4BY PF 4
- A4BT PF 6

Class RK1

- A2D-R & A6D-R PF 8
- A2K-R & A6K-R PF 10

Class RK5

- TR-R & TRS-R PF 12
- TRS-RDC PF 14

Class J

- AJT PF 16
- AJT Reducer Fuses PF 18
- HSJ PF 20
- A4J PF 22

Class CC

- ATDR PF 24
- ATQR PF 26
- ATMR PF 28

Class G

- AG PF 29

Class K-5

- OT/OTN/OTS PF 30

Class T

- A3T & A6T PF 32

Canadian Fuses

- Class C PF 34
- Class H NRN/NRS PF 36
- Class H CRN/CRS PF 37

Accessories

- Fuse Pullers/Clip Clamps... PF 38

A4BQ

Time Delay/Class L

UL/CSA LISTED POWER FUSES

PUT THE HIGHEST CURRENT-LIMITATION...
AT YOUR SERVICE



Amp-Trap 2000® A4BQ fuses are 20% more current-limiting than any other Class L fuse on the market. When correctly coordinated, they bring a superior level of protection to service entrance equipment. Downstream circuit components have maximum protection against short circuit let-thru current. A4BQ's built-in, 4-second time-delay characteristic (at 500% of rated current) accommodates harmless inrush currents without nuisance opening.

FEATURES/BENEFITS:

- Fastest operation under short circuit conditions: Let-thru currents are typically 20% lower, with a corresponding let-thru energy (clearing I^2t) up to 40% lower than the next fastest Class L fuse
- Time-delay for high inrush loads such as motors and transformers, without nuisance opening
- 300kA interrupting rating - self-certified, UL witnessed tests
- Most current-limiting for lowest peak let-thru current; even at fault currents up to 300kA
- Recommended for Arc Flash energy reduction
- Pure silver links ensure lowest let-thru current and longer fuse life
- Easy 2-to-1 selectivity for prevention of nuisance shutdowns and "blackouts"
- Rejection-style design prevents replacement errors
- High-visibility orange label gives instant brand recognition
- Reduced inventory because A4BQ can replace all older types of Class L fuses now in-service (continued on next page)

RATINGS:

Volts: 600VAC, 500VDC

Amps: AC - 100 to 6000A,
DC - 100 to 3000A

IR: 200kA I.R. AC, 100kA
I.R. DC (Self-certified for
600VAC, 300kA I.R., UL
witnessed).

APPLICATIONS:

- Mains
- Feeders
- Large motors
- Lighting, heating & general loads
- Circuit breaker back-up
- DC rated: UPS DC links, battery disconnects, other DC applications

APPROVALS:

A4BQ (100-6000)

- UL listed to standard 248-10
File E2137
- DC listed to UL standard 248 (100-2000A)
- CSA certified to standard C22.2 No. 248.10 (601-6000A)

A4BQ (100-6000) - TA

- UL listed



FEATURES/BENEFITS (CONTINUED):

- Metal-embossed date and catalog number for traceability and lasting identification
- Fiberglass body provides dimensional stability in harsh industrial settings
- High-grade silica filler ensures fast arc quenching
- Optional mechanical TA indicator (100-6000A). Please contact factory for special trigger actuator

CATALOG NUMBERS (AMPS) RECOMMENDED FUSE BLOCKS FOR AMP-TRAP® CLASS L FUSES

A4BQ100	A4BQ500	A4BQ1000	A4BQ2000
A4BQ150	A4BQ600	A4BQ1200	A4BQ2500
A4BQ200	A4BQ601	A4BQ1350	A4BQ2501
A4BQ250	A4BQ650	A4BQ1400	A4BQ3000
A4BQ300	A4BQ700	A4BQ1500	A4BQ3500
A4BQ350	A4BQ750	A4BQ1600	A4BQ3800
A4BQ400	A4BQ800	A4BQ1800	A4BQ4000
A4BQ450	A4BQ900	A4BQ1900	A4BQ5000
			A4BQ6000

Fuse Ampere Rating	Catalog Number 600V or Less 3 Pole
100-800	P48F
801-1200	P412F

Catalog number P48F is UL recognized
Catalog number P412F is self-certified

Note: For remote blown fuse trigger actuator option add "-TA" to end of catalog number. Example: A4BQ1600-TA

DIMENSIONS

Ampere Rating	A		B		C		D		E	
	in	mm	in	mm	in	mm	in	mm	in	mm
100-600	8-5/8	219	2	51	5/16	8	1-5/8	41	2-13/32	61
601-800	8-5/8	219	2-1/2	63	3/8	9	2	51	2-13/32	61
801-1200	10-3/4	273	2-1/2	63	3/8	9	2	51	3-15/32	88
1201-1600	10-3/4	273	3	76	7/16	11	2-3/8	60	3-15/32	88
1601-2000	10-3/4	273	3-1/2	89	1/2	12	2-3/4	70	3-15/32	88
2001-2500	10-3/4	273	4-1/2	114	3/4	19	3-1/2	89	3-15/32	88
2501-3000	10-3/4	273	5	127	3/4	19	4	102	3-15/32	88
3001-4000	10-3/4	273	5-3/4	146	3/4	19	4-3/4	121	3-15/32	88
4001-5000	10-3/4	273	6-1/4	159	1	25	5-1/4	133	3-15/32	88
5001-6000	10-3/4	273	7-1/8	181	1	25	5-3/4	146	3-15/32	88

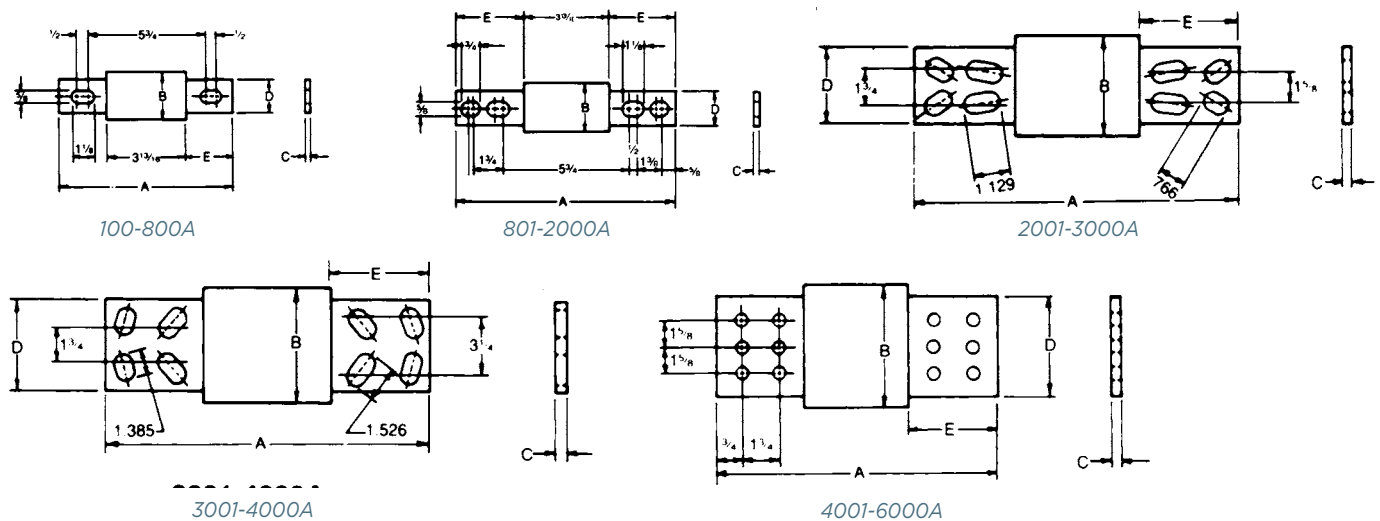

Safety Note: Class L fuses are dimensioned for one-way interchangeability.
A Class L fuse of any lower ampere rating can be substituted for a given Class L fuse.

A4BY

Class L

UL/CSA LISTED POWER FUSES

COUNT ON THE HIGH INTERRUPTING RATING
OF OUR MOST WIDELY USED CLASS L FUSE



When it comes to protecting service entrance equipment, feeder circuits, and circuit breakers, A4BY fuses are the industry's favorite. The A4BY is a 100% rated device and may be applied at continuous currents up to its ampere rating. A 4-second minimum time-delay at 500% rating allows the A4BY to pass normal current surges and to coordinate with ground fault relays.

FEATURES/BENEFITS:

- Unique dimensions prevent replacement by other fuse classes
- Blade stamped catalog numbers for permanent identification
- Glass melamine body and plated terminals provide superior reliability in harsh environments

RATINGS:

- **Volts:** 600VAC, 300VDC
- **Amps:** 200 to 6,000A (AC), 200 to 2,500A (DC)
- **IR:** 200kA.I.R. AC, 100kA I.R. DC

HIGHLIGHTS:

- Current-limiting
- 4-second time-delay
- DC ratings
- Uniform characteristics in all ampere ratings

APPLICATIONS:

- Mains, feeders
- Circuit breakers
- Load centers
- Panelboards
- Switchboards
- Metering centers

APPROVALS:

- UL listed to standard 248-10 (601-6000A) File E2137
- CSA certified to standard C22.2 No. 248.10 (601-6000A)
- Self-certified for DC per UL248 (601-6000A)



CATALOG NUMBERS (AMPS)

A4BY200	A4BY700	A4BY1350	A4BY2500
A4BY250	A4BY750	A4BY1400	A4BY3000
A4BY300	A4BY800	A4BY1500	A4BY3001
A4BY350	A4BY801	A4BY1600	A4BY3500
A4BY400	A4BY900	A4BY1601	A4BY4000
A4BY450	A4BY1000	A4BY1800	A4BY4001
A4BY500	A4BY1100	A4BY2000	A4BY4500
A4BY600	A4BY1200	A4BY2001	A4BY5000
A4BY601	A4BY1201	A4BY2200	A4BY6000
A4BY650			

Note: For optional blown fuse trigger indicator add "-TI" to the end of part number.
Example: A4BY1600-TI. Consult factory for availability.

RECOMMENDED FUSE BLOCKS
FOR AMP-TRAP® CLASS L FUSES

Fuse Ampere Rating	Catalog Number 600V or Less 3-Pole
100-800	P48F
801-1200	P412F

Catalog number P48F is UL recognized
Catalog number P412F is self-certified

A variety of pole configurations and termination provisions are available. Refer to Section FB for details.

DIMENSIONS

Ampere Rating	A		B		C		D		E	
	in	mm	in	mm	in	mm	in	mm	in	mm
200-600	8-5/8	219	2	51	5/16	8	1-5/8	41	2-13/32	61
601-800	8-5/8	219	2-1/2	63	3/8	9	2	51	2-13/32	61
801-1200	10-3/4	273	2-1/2	63	3/8	9	2	51	3-15/32	88
1201-1600	10-3/4	273	3	76	7/16	11	2-3/8	60	3-15/32	88
1601-2000	10-3/4	273	3-1/2	89	1/2	13	2-3/4	70	3-15/32	88
2001-2500	10-3/4	273	4-1/2	114	3/4	19	3-1/2	89	3-15/32	88
2501-3000	10-3/4	273	5	127	3/4	19	4	102	3-15/32	88
3001-4000	10-3/4	273	5-3/4	146	3/4	19	4-3/4	121	3-15/32	88
4001-5000	10-3/4	273	6-1/4	159	1	25	5-1/4	133	3-15/32	88
5001-6000	10-3/4	273	7-1/8	181	1	25	5-3/4	146	3-15/32	88

Safety Note: Class L fuses are dimensioned for one-way interchangeability.
A Class L fuse of any lower ampere rating can be substituted for a given Class L fuse.

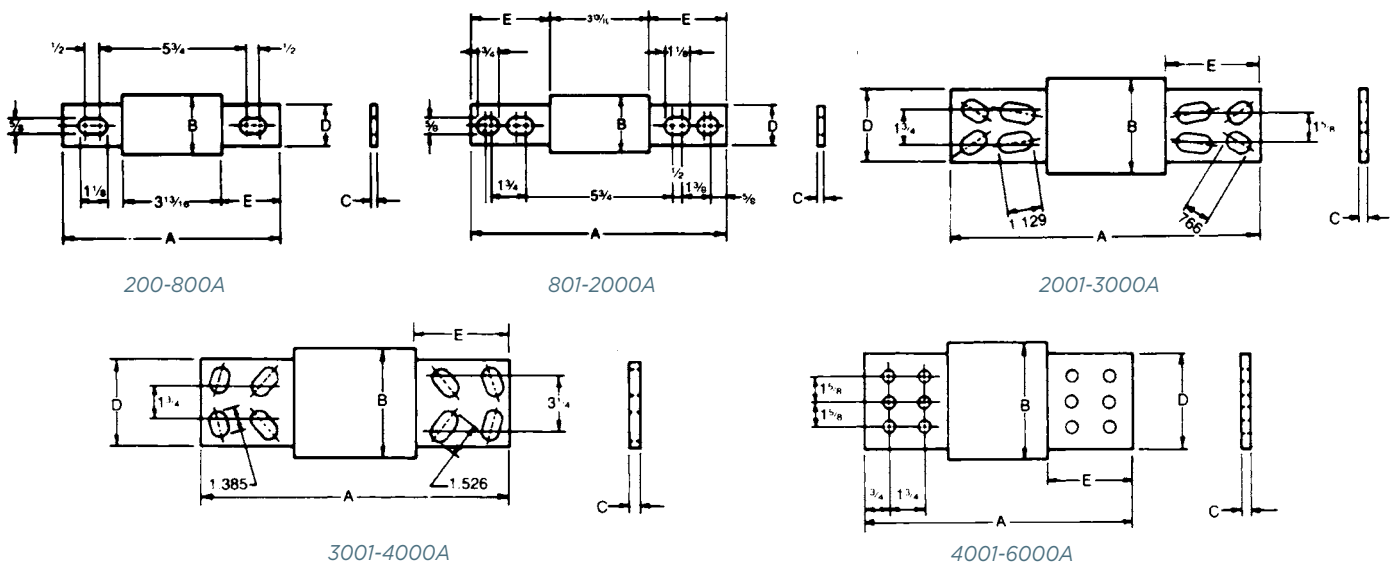

A4BT

Time Delay/Class L

UL/CSA LISTED POWER FUSES

WHEN YOUR HEAVIER LOADS NEED PROTECTION,
A4BT FUSES WON'T LET YOU DOWN



The high interrupting rating of A4BT current-limiting fuses is ideally suited for protecting mains, feeders, and general circuits. The 10-second time-delay at 500% of fuse rating is ideal for large motors and other loads with a high inrush. A4BT fuses are suitable for DC applications up to 500VDC. An A4BT fuse can be applied to normal loads up to its full ampere rating to allow 100% rating of equipment, while also providing superior current-limiting ability.

FEATURES/BENEFITS:

- Unique dimensions prevent replacement by other fuse classes.
- Blade-stamped catalog numbers for permanent identification
- Glass melamine body and plated terminals provide superior reliability in harsh environments

RATINGS:

- **Volts:** 600VAC, 500VDC
- **Amps:** 200 to 2,000A
- **IR:** 200kA I.R. AC, 100kA I.R. DC

HIGHLIGHTS:

- Current-limiting
- Full 10-second delay
- DC ratings
- Uniform characteristics in all ampere ratings

APPLICATIONS:

- Motors
- Motor controllers
- Transformers
- Mains
- Feeders

APPROVALS:

- UL Listed to standard 248-10 (601-2000A) File E2137
- CSA Certified to standard C22.2 No. 248.10 (601-2000A)
- Self-certified for DC per UL248 (601-2000)



CATALOG NUMBERS (AMPS)

A4BT200	A4BT500	A4BT800	A4BT1400
A4BT250	A4BT600	A4BT900	A4BT1500
A4BT300	A4BT601	A4BT1000	A4BT1600
A4BT350	A4BT650	A4BT1100	A4BT1800
A4BT400	A4BT700	A4BT1200	A4BT2000
A4BT450	A4BT750		

RECOMMENDED FUSE BLOCKS
FOR AMP-TRAP® CLASS L FUSES

Fuse Ampere Rating	Catalog Number 600V or Less 3-Pole
100-800	P48F
801-1200	P412F

Catalog number P48F is UL recognized
Catalog number P412F is self-certified

A variety of pole configurations and termination provisions are available. Refer to Section FB for details.

DIMENSIONS

Ampere Rating	A		B		C		D		E	
	in	mm	in	mm	in	mm	in	mm	in	mm
200-600	8-5/8	219	2	51	5/16	8	1-5/8	41	2-13/32	61
601-800	8-5/8	219	2-1/2	63	3/8	9	2	51	2-13/32	61
801-1200	10-3/4	273	2-1/2	63	3/8	9	2	51	3-15/32	88
1201-1600	10-3/4	273	3	76	7/16	11	2-3/8	60	3-15/32	88
1601-2000	10-3/4	273	3-1/2	89	1/2	13	2-3/4	70	3-15/32	88

Safety Note: Class L fuses are dimensioned for one-way interchangeability.
A Class L fuse of any lower ampere rating can be substituted for a given Class L fuse.

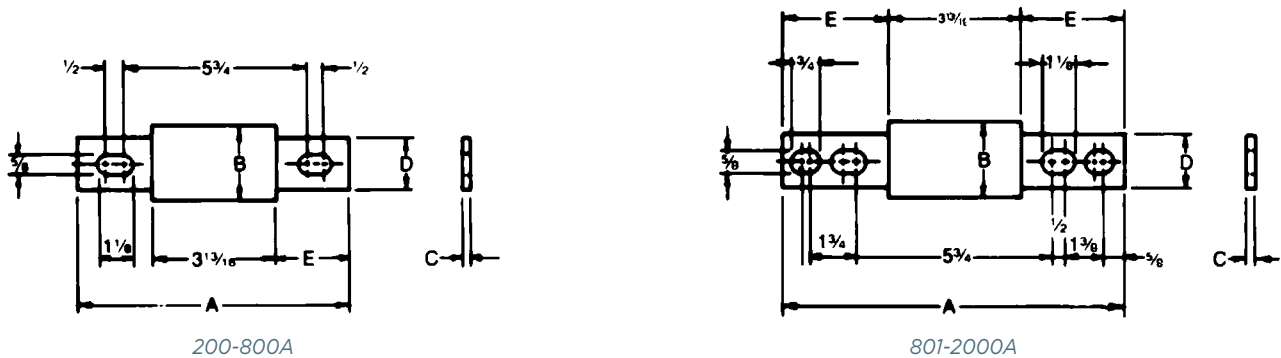

A2D-R & A6D-R

Time Delay/Class RK1

UL/CSA LISTED POWER FUSES

UPGRADE YESTERDAY'S CIRCUITS TO
TODAY'S TYPE 2 PROTECTION



The Amp-Trap 2000® SmartSpot® A2D-R and A6D-R fuses feature a visual open fuse indicator and provide IEC Type 2 No Damage protection to main, feeder, and branch circuits for all types of loads. With time-delay characteristics for handling harmless inrush currents, current-limiting ability and a wide range of ratings (from 1 to 600 Amperes), A2D-R and A6D-R fuses give excellent protection for all your applications.

FEATURES/BENEFITS:

- Solid state SmartSpot visual blown fuse indicator
- Time-delay for motor starting and transformer inrush currents without nuisance opening
- 600VAC & 600VDC dual rated
- 300kA interrupting rating - self-certified, UL witnessed tests
- Extremely current-limiting for low peak let-thru current
- Recommended for Arc Flash energy reduction
- Easy 2-to-1 selectivity for prevention of nuisance shut downs and “black outs”
- Rejection-style design prevents replacement errors (when used with recommended fuse blocks)
- High-visibility orange label gives instant brand recognition
- Reduced inventory by taking the place of class RK5, K, and H fuses
- Metal-embossed date and catalog number for easier traceability and lasting identification
- Fiberglass body provides dimensional stability in harsh industrial settings

RATINGS:

A2D-R

Volts: 250VAC/DC

Amps: 1/10 to 600A (AC),
15 to 600A (DC)

IR: 200kA I.R. AC,
100kA I.R. DC

A6D-R

Volts: 600VAC/DC

Amps: 1/10 to 600A

IR: 200kA I.R. AC, 100kA I.R.
DC (Self-certified for 300kA
I.R., UL witnessed.)

APPLICATIONS:

- Motors
- Safety switches
- Transformers
- Branch circuit protection
- Disconnects
- Control panels
- All general-purpose circuits

Note: See motor fuse applications tables on page P7

APPROVALS:

- UL listed to standard 248-12 File E2137
- DC listed to UL standard 248
- CSA certified to standard C22.2 No. 248.12



CATALOG NUMBERS (AMPS)

250V			600V		
A2D1/10R	A2D3-1/2R	A2D50R	A6D1/10R	A6D3-1/2R	A6D50R
A2D15/100R	A2D4R	A2D60R	A6D15/100R	A6D4R	A6D60R
A2D2/10R	A2D4-1/2R	A2D70R	A6D2/10R	A6D4-1/2R	A6D70R
A2D3/10R	A2D5R	A2D75R	A6D3/10R	A6D5R	-
A2D4/10R	A2D5-6/10R	A2D80R	A6D4/10R	A6D5-6/10R	A6D80R
A2D1/2R	A2D6R	A2D90R	A6D1/2R	A6D6R	A6D90R
A2D6/10R	A2D6-1/4R	A2D100R	A6D6/10R	A6D6-1/4R	A6D100R
A2D8/10R	A2D7R	A2D110R	A6D8/10R	A6D7R	A6D110R
A2D1R	A2D8R	A2D125R	A6D1R	A6D8R	A6D125R
A2D1-1/8R	A2D9R	A2D150R	A6D1-1/8R	A6D9R	A6D150R
A2D1-1/4R	A2D10R	A2D175R	A6D1-1/4R	A6D10R	A6D175R
A2D1-4/10R	A2D12R	A2D200R	A6D1-4/10R	A6D12R	A6D200R
A2D1-6/10R	A2D15R	A2D225R	A6D1-6/10R	A6D15R	A6D225R
A2D1-8/10R	A2D17-1/2R	A2D250R	A6D1-8/10R	A6D17-1/2R	A6D250R
A2D2R	A2D20R	A2D300R	A6D2R	A6D20R	A6D300R
A2D2-1/4R	A2D25R	A2D350R	A6D2-1/4R	A6D25R	A6D350R
A2D2-1/2R	A2D30R	A2D400R	A6D2-1/2R	A6D30R	A6D400R
A2D2-8/10R	A2D35R	A2D450R	A6D2-8/10R	A6D35R	A6D450R
A2D3R	A2D40R	A2D500R	A6D3R	A6D40R	A6D500R
A2D3-2/10R	A2D45R	A2D600R	A6D3-2/10R	A6D45R	A6D600R

Note: SmartSpot visual indicator is not available (1/10-7A)

RECOMMENDED
FUSE BLOCKS WITH
BOX CONNECTORS FOR
AMP-TRAP® CLASS RK1
FUSES

Fuse Ampere Rating	Catalog Number			
	250V or Less		600V or Less	
	1 Pole	3 Pole	1 Pole	3 Pole
0-30	20306R	20308R	60306R	60308R
31-60	20606R	20608R	60606R	60608R
61-100	21036R	21038R	61036R	61038R
101-200	22001R	22003R	62001R	62003R
201-400	24001R	24003R	64001R	64003R
401-600	2631R	2633R	6631R	6633R

A variety of pole configurations and termination provisions are available. Refer to Section FB for details.

DIMENSIONS

Ampere Rating	A		B		C		D		E	
	In	mm	In	mm	In	mm	In	mm	In	mm
250V-A2D										
0-30	2	51	9/16	14	-	-	-	-	-	-
31-60	3	76	13/16	21	-	-	-	-	-	-
61-100	5-7/8	149	1-1/16	27	1/8	3	3/4	19	1	25
101-200	7-1/8	181	1-9/16	40	3/16	5	1-1/8	28	1-3/8	35
201-400	8-5/8	219	2-1/16	53	1/4	6	1-5/8	41	1-7/8	48
401-600	10-3/8	264	2-9/16	66	1/4	6	2	51	2-1/4	57
600V-A6D										
0-30	5	127	13/16	21	-	-	-	-	-	-
31-60	5-1/2	139	1-1/16	27	-	-	-	-	-	-
61-100	7-7/8	200	1-5/16	34	1/8	3	3/4	19	1	25
101-200	9-5/8	244	1-13/16	46	3/16	5	1-1/8	28	1-3/8	35
201-400	11-5/8	295	2-9/16	66	1/4	6	1-5/8	41	1-7/8	48
401-600	13-3/8	340	3-1/8	80	1/4	6	2	51	2-1/4	57

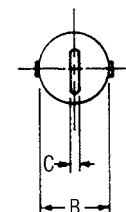
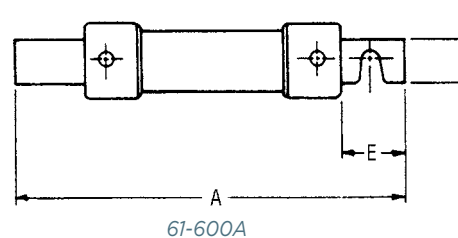
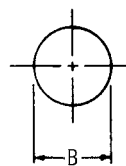
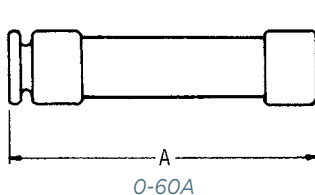

A2K-R & A6K-R

Fast Acting/Class RK1

UL/CSA LISTED POWER FUSES

THESE FAST-ACTING FUSES DELIVER A HIGH DEGREE OF CURRENT LIMITATION WHERE YOU NEED IT MOST



Current-limiting A2K and A6K fuses provide excellent protection where high available short circuit currents exist. These fast-acting fuses are particularly good for branch/feeder circuits and back-up protection.

FEATURES/BENEFITS:

- Rejection style design prevents replacement by other fuse classes
- Fiberglass body provides dimensional stability in harsh industrial environments
- Easy-to-read imprint label for quick recognition and replacement
- High degree of current limitation for low peak let-thru current

RATINGS:

A2K

- **Volts:** 250VAC / DC
- **Amps:** 1 to 600A
- **IR:** 200kA I.R. AC, 20kA I.R. DC

A6K

- **Volts:** 600VAC / 300VDC
- **Amps:** 1 to 600A
- **IR:** 200kA I.R. AC, 20kA I.R. DC

HIGHLIGHTS

- Highly current-limiting
- Fast-acting
- Rejection style

APPLICATIONS:

- Loadcenters
- Panelboards
- Switchboards
- Bus duct
- Feeder circuits
- Non-inductive loads
- Lighting circuits

APPROVALS:

- UL listed to standard 248-12 File E2137
- CSA certified to standard C22.2 No. 248.12
- Self-certified for DC per UL248



CATALOG NUMBERS (AMPS)

250V			600V		
A2K1R	A2K35R	A2K175R	A6K1R	A6K35R	A6K175R
A2K3R	A2K40R	A2K200R	A6K3R	A6K40R	A6K200R
-	A2K45R	A2K225R	A6K4R	A6K45R	A6K225R
A2K5R	A2K50R	A2K250R	A6K5R	A6K50R	A6K250R
A2K6R	A2K60R	A2K300R	A6K6R	A6K60R	A6K300R
-	A2K70R	A2K350R	A6K8R	A6K70R	A6K350R
A2K10R	A2K80R	A2K400R	A6K10R	A6K80R	A6K400R
A2K15R	A2K100R	A2K500R	A6K15R	A6K100R	A6K500R
A2K20R	A2K110R	A2K600R	A6K20R	A6K110R	A6K600R
A2K25R	A2K125R		A6K25R	A6K125R	
A2K30R	A2K150R		A6K30R	A6K150R	

RECOMMENDED FUSE BLOCKS
WITH BOX CONNECTORS FOR
AMP-TRAP® CLASS RK1 FUSES

Fuse Ampere Rating	Catalog Number			
	250V		600V	
	1-Pole	3-Pole	1-Pole	3-Pole
0-30	20306R	20308R	60306R	60308R
31-60	20606R	20608R	60606R	60608R
61-100	21036R	21038R	61036R	61038R
101-200	22001R	22003R	62001R	62003R
201-400	24001R	24003R	64001R	64003R
401-600	2631R	2633R	6631R	6633R

A variety of pole configurations and termination provisions are available. Refer to Section FB for details.

DIMENSIONS

Ampere Rating	A		B		C		D		E	
	in	mm	in	mm	in	mm	in	mm	in	mm
250V-A2K Fuses										
0-30	2	51	9/16	14	-	-	-	-	-	-
31-60	3	76	13/16	21	-	-	-	-	-	-
61-100	5-7/8	149	1-1/16	27	1/8	3	3/4	19	1	25
101-200	7-1/8	181	1-9/16	40	3/16	5	1-1/8	28	1-3/8	35
201-400	8-5/8	219	2-1/16	53	1/4	6	1-5/8	41	1-7/8	48
401-600	10-3/8	264	2-9/16	66	1/4	6	2	51	2-1/4	57
600V-A6K Fuses										
0-30	5	127	13/16	21	-	-	-	-	-	-
31-60	5-1/2	139	1-1/16	27	-	-	-	-	-	-
61-100	7-7/8	200	1-5/16	34	1/8	3	3/4	19	1	25
101-200	9-5/8	244	1-13/16	46	3/16	5	1-1/8	28	1-3/8	35
201-400	11-5/8	295	2-9/16	66	1/4	6	1-5/8	41	1-7/8	48
401-600	13-3/8	340	3-1/8	80	1/4	6	2	51	2-1/4	57

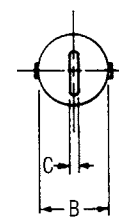
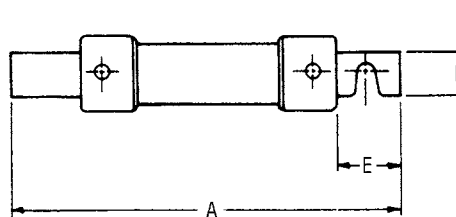
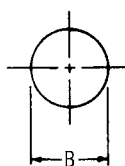
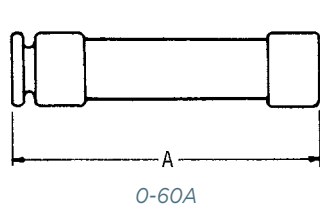

TR-R & TRS-R

Time Delay/Class RK5

UL/CSA LISTED POWER FUSES

THE INDUSTRY'S MOST POPULAR FUSE
FOR MOTOR CIRCUIT PROTECTION



With advanced material technology added to the existing product, the Tri-Onic® TR and TRS current-limiting time-delay fuses are engineered for overcurrent protection of motors and transformers, service entrance equipment, feeder and branch circuits. Tri-Onic fuse's proven time-delay characteristic safely handles harmless starting currents and inrush currents associated with today's motors and transformers. Now available with optional SmartSpot® blown fuse indication technology.

FEATURES/BENEFITS:

- Time-delay
- Current-limiting
- AC & DC rated
- Optional solid state SmartSpot blown fuse indicator
- Time-delay for motor start-ups and transformer inrush currents without nuisance opening
- Current-limiting for low peak let-thru current
- Rejection-style design prevents replacement errors (when used with recommended fuse blocks)
- Easy-to-read label for quick brand recognition and replacement
- Metal-embossed date and catalog number for traceability and lasting identification
- Fiberglass body provides dimensional stability in harsh industrial settings
- High-grade silica filler ensures fast arc quenching and high current limitation

RATINGS:

TR-R

- **Volts:** 250VAC; 250VDC (.1-2.8A; 35-400A); 160VDC (3-30A; 450-600A)
- **Amps:** 1/10 to 600A
- **IR:** 200kA I.R. AC / 20kA I.R. DC

TRS-R

- **Volts:** 600VAC; 600VDC (.1-12A; 70-600A); 300VDC (15-60A)
- **Amps:** 1/10 to 600A
- **IR:** 200kA I.R. AC; 1/10A to 60A -> 20kA I.R. DC; 70A to 600A -> 100kA I.R. DC

APPLICATIONS:

- Motor circuits
- Mains
- Feeders
- Branch circuits
- Transformers
- Service entrance equipment
- General-purpose equipment

APPROVALS:

- UL listed to standard 248-12 File E2137
- CSA certified to standard C22.2 no. 248.12
- DC listed to UL standard 248 TRS only



CATALOG NUMBERS (AMPS)

250V			600V		
TR1/10R*	TR3-1/2R*	TR50R	TRS1/10R*	TRS3-1/2R*	TRS50R
TR15/100R*	TR4R*	TR60R	TRS15/100R*	TRS4R*	TRS60R
TR2/10R*	TR4-1/2R*	TR70R	TRS2/10R*	TRS4-1/2R*	TRS70R
TR3/10R*	TR5R*	TR75R*	TRS3/10R*	TRS5R*	TRS75R*
TR4/10R*	TR5-6/10R*	TR80R	TRS4/10R*	TRS5-6/10R*	TRS80R
TR1/2R*	TR6R*	TR90R	TRS1/2R*	TRS6R*	TRS90R
TR6/10R*	TR6-1/4R*	TR100R	TRS6/10R*	TRS6-1/4R*	TRS100R
TR8/10R*	TR7R*	TR110R	TRS8/10R*	TRS7R*	TRS110R
TR1R*	TR8R	TR125R	TRS1R*	TRS8R	TRS125R
TR1-1/8R*	TR9R	TR150R	TRS1-1/8R*	TRS9R	TRS150R
TR1-1/4R*	TR10R	TR175R	TRS1-1/4R*	TRS10R	TRS175R
TR1-4/10R*	TR12R	TR200R	TRS1-4/10R*	TRS12R	TRS200R
TR1-6/10R*	TR15R	TR225R	TRS1-6/10R*	TRS15R	TRS225R
TR1-8/10R*	TR17-1/2R	TR250R	TRS1-8/10R*	TRS17-1/2R	TRS250R
TR2R*	TR20R	TR300R	TRS2R*	TRS20R	TRS300R
TR2-1/4R*	TR25R	TR350R	TRS2-1/4R*	TRS25R	TRS350R
TR2-1/2R*	TR30R	TR400R	TRS2-1/2R*	TRS30R	TRS400R
TR2-8/10R*	TR35R	TR450R	TRS2-8/10R*	TRS35R	TRS450R
TR3R*	TR40R	TR500R	TRS3R*	TRS40R	TRS500R
TR3-2/10R*	TR45R	TR600R	TRS3-2/10R*	TRS45R	TRS600R

RECOMMENDED
FUSE BLOCKS WITH
BOX CONNECTORS FOR
TRI-ONIC® CLASS RK5 FUSES

Fuse Ampere Rating	Catalog Number			
	250V		600V	
	1-Pole	3-Pole	1-Pole	3-Pole
0-30	20306R	20308R	60306R	60308R
31-60	20606R	20608R	60606R	60608R
61-100	21036R	21038R	61036R	61038R
101-200	22001R	22003R	62001R	62003R
201-400	24001R	24003R	64001R	64003R
401-600	2631R	2633R	6631R	6633R

A variety of pole configurations and termination provisions are available. Refer to Section FB for details.

Note: Optional blown fuse visual indication available. To order, place "ID" at the end of the catalog number. Example: #TRS30RID

* Not available with optional blow fuse indicator.

Tin plated end caps are available on Non-ID fuses less than 60A. Example Part # TRP30R, TRSP30R

DIMENSIONS

Ampere Rating	A		B		C		D		E	
	In.	mm	In.	mm	In.	mm	In.	mm	In.	mm
250V-TR Fuses										
0-30	2	51	9/16	14	-	-	-	-	-	-
31-60	3	76	13/16	21	-	-	-	-	-	-
61-100	5-7/8	149	1-1/16	27	1/8	3	3/4	19	1	25
101-200	7-1/8	181	1-9/16	40	3/16	5	1-1/8	28	1-3/8	35
201-400	8-5/8	219	2-1/16	53	1/4	6	1-5/8	41	1-7/8	48
401-600	10-3/8	264	2-9/16	66	1/4	6	2	51	2-1/4	57
600V-TRS Fuses										
0-30	5	127	13/16	21	-	-	-	-	-	-
31-60	5-1/2	139	1-1/16	27	-	-	-	-	-	-
61-100	7-7/8	200	1-5/16	34	1/8	3	3/4	19	1	25
101-200	9-5/8	244	1-13/16	46	3/16	5	1-1/8	28	1-3/8	35
201-400	11-5/8	295	2-9/16	66	1/4	6	1-5/8	41	1-7/8	48
401-600	13-3/8	340	3-1/8	80	1/4	6	2	51	2-1/4	57

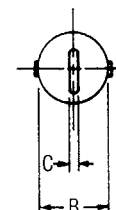
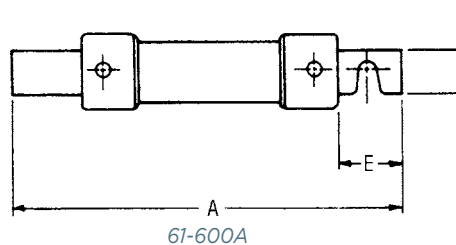
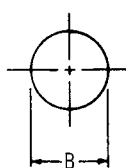
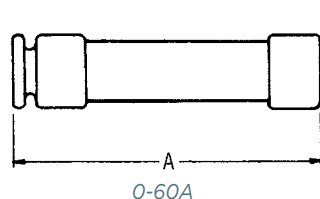

TRS-RDC

Time Delay/Class RK5

UL/CSA LISTED POWER FUSES

DC RATED FOR TOUGH DC APPLICATIONS



The Tri-Onic® DC fuse series is designed for DC circuit protection in surface and underground mines. The TRS-RDC is MSHA approved and meets the industry's most severe third party requirements for 600VDC rated fuses. The TRS-RDC is a time-delay fuse with essentially the same time-current characteristics as the standard Tri-Onic fuse.

FEATURES/BENEFITS:

- DC rated for mine duty and other long time-constant applications
- Time-delay for motor start-ups and high inrush loads without nuisance opening
- Rugged glass melamine body for superior reliability in harsh environments

RATINGS:

- **Volts:** 300VDC (0.1 to 30A); 600VDC (35 to 400A)
- **Amps:** 1/10 to 400A
- **IR:** 20kA I.R. DC

HIGHLIGHTS:

- Time-delay
- DC rated

APPLICATIONS:

- Mine circuits
- Trailing cables
- Pump motors
- Rail heaters

APPROVALS:

- MSHA approval no. 28-26-0

CATALOG NUMBERS (AMPS)

TRS1/10RDC	TRS1-8/10RDC	TRS6-1/4RDC	TRS60RDC
TRS15/100RDC	TRS2RDC	TRS8RDC	TRS70RDC
TRS2/10RDC	TRS2-1/4RDC	TRS9RDC	TRS80RDC
TRS3/10RDC	TRS2-1/2RDC	TRS10RDC	TRS90RDC
TRS4/10RDC	TRS2-8/10RDC	TRS12RDC	TRS100RDC
TRS1/2RDC	TRS3RDC	TRS15RDC	TRS125RDC
TRS6/10RDC	TRS3-2/10RDC	TRS17-1/2RDC	TRS150RDC
TRS8/10RDC	TRS3-1/2RDC	TRS20RDC	TRS175RDC
TRS1RDC	TRS4RDC	TRS30RDC	TRS200RDC
TRS1-1/8RDC	TRS4-1/2RDC	TRS35RDC	TRS250RDC
TRS1-1/4RDC	TRS5RDC	TRS40RDC	TRS300RDC
TRS1-4/10RDC	TRS5-6/10RDC	TRS45RDC	TRS400RDC
TRS1-6/10RDC	TRS6RDC	TRS50RDC	

RECOMMENDED
FUSE BLOCKS WITH
BOX CONNECTORS FOR
TRI-ONIC® CLASS RK5 FUSES

Fuse Ampere Rating	Catalog Number			
	250V		600V	
	1-Pole	3-Pole	1-Pole	3-Pole
0-30	20306R	20308R	60306R	60308R
31-60	20606R	20608R	60606R	60608R
61-100	21036R	21038R	61036R	61038R
101-200	22001R	22003R	62001R	62003R
201-400	24001R	24003R	64001R	64003R

A variety of pole configurations and termination provisions are available. Refer to Section FB for details.

DIMENSIONS

Ampere Rating	A		B		C		D		E	
	In.	mm	In.	mm	In.	mm	In.	mm	In.	mm
0-30	5	127	13/16	21	-	-	-	-	-	-
31-60	5-1/2	139	1-1/16	27	-	-	-	-	-	-
61-100	7-7/8	200	1-5/16	34	1/8	3	3/4	19	1	25
101-200	9-5/8	244	1-13/16	46	3/16	5	1-1/8	28	1-3/8	35
201-400	11-5/8	295	2-9/16	66	1/4	6	1-5/8	41	1-7/8	48

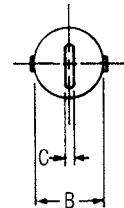
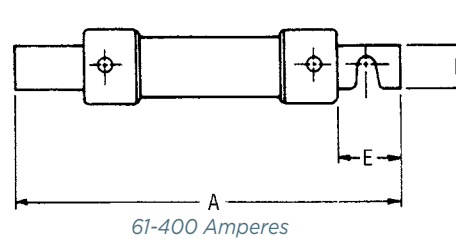
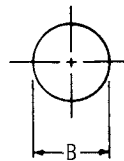
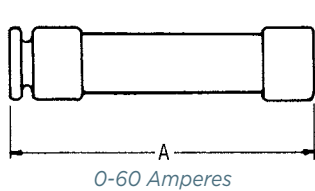

AJT

Time Delay/Class J

UL/CSA LISTED POWER FUSES

SMARTSPOT® WITH MAXIMUM CIRCUIT PROTECTION



Amp-Trap 2000® SmartSpot AJT fuses now provide a visual open fuse indicator. With advanced material technology the AJT fuse provides IEC Type 2 No Damage protection to main, feeder, and branch circuits, for all types of loads – yet, they require only half the mounting space needed for 600VAC Class RK fuses. AJT's time-delay characteristics are ideal for handling typical motor and transformer inrush currents, while also providing superior current-limiting ability.

FEATURES/BENEFITS:

- Solid state SmartSpot visual blown fuse indicator
- Time-delay for motor starting and transformer inrush
- 300kA interrupting rating - self-certified, UL witnessed tests
- Extremely current-limiting for low peak let-thru current
- Most current-limiting UL class fuse
- Recommended for Arc Flash energy reduction
- Small footprint requires less mounting space and allows smaller, more economical fuse blocks
- Easy 2-to-1 selectivity for prevention of nuisance shutdowns
- Unique Class J dimensions prevent replacement errors
- High-visibility orange label gives instant brand recognition
- Metal-embossed date and catalog number for traceability and lasting identification
- Fiberglass body provides dimensional stability in harsh industrial settings
- High-grade silica filler ensures fast arc quenching
- Optional EI indicator/switch mount for AJT70 to 600 open fuse indication

RATINGS:

- **Volts:** 600VAC or less, 500VDC or less
- **Amps:** 1 to 600A
- **IR:** 200kA I.R. AC, 100kA I.R. DC (Self-certified for 600VAC, 300kA I.R., UL witnessed).

APPLICATIONS:

- Motor circuits
- Mains
- Feeders
- Branch circuits
- Lighting, heating & general loads
- Transformers
- Control panels
- Circuit breaker back-up
- Bus duct
- Load centers

APPROVALS:

AJT (1-600):

- UL listed to standard 248-8 File E2137
- DC listed to UL standard 248
- CSA certified to standard C22.2 No. 248.8
- IEC 269-2-1

AJT (70-600) EI:

- UL listed
- DC tested to UL standard 248



CATALOG NUMBERS (AMPS)

AJT1	AJT4-1/2	AJT25	AJT125
AJT1-1/4	AJT5	AJT30	AJT150
AJT1-1/2	AJT5-6/10	AJT35	AJT175
AJT1-6/10	AJT6	AJT40	AJT200
AJT1-8/10	AJT6-1/4	AJT45	AJT225
AJT2	AJT7	AJT50	AJT250
AJT2-1/4	AJT8	AJT60	AJT300
AJT2-1/2	AJT9	AJT70	AJT350
AJT2-8/10	AJT10	AJT80	AJT400
AJT3	AJT12	AJT90	AJT450
AJT3-2/10	AJT15	AJT100	AJT500
AJT3-1/2	AJT17-1/2	AJT110	AJT600
AJT4	AJT20		

Note: SmartSpot visual indicator is not available (1-7A)

RECOMMENDED FUSE BLOCKS
WITH BOX CONNECTORS FOR
AMP-TRAP® CLASS J FUSES

Fuse Ampere Rating	Catalog Number 600V or Less	
	1 Pole	3 Pole
0-30	US3J1I	US3J3I
31-60	US6J1I	US6J3I
61-100	61036J	61038J
101-200	62001J	62003J
201-400	64031J	64033J
401-600	6631J	6633J

A variety of pole configurations and termination provisions are available. Refer to Section FB for details.

DIMENSIONS

Ampere Rating	A		B		C		D		E		F		G		H	
	in	mm	in	mm	in	mm	in	mm	in	mm	in	mm	in	mm	in	mm
1-30	2-1/4	57	13/16	21	-	-	-	-	-	-	-	-	-	-	-	-
31-60	2-3/8	60	1-1/16	27	-	-	-	-	-	-	-	-	-	-	-	-
61-100	4-5/8	117	1-1/16	27	1/8	3.2	3/4	19	1	25	3-5/8	92	3/8	10	9/32	7
101-200	5-3/4	146	1-5/8	41	3/16	4.8	1-1/8	29	1-3/8	35	4-3/8	111	3/8	10	9/32	7
201-400	7-1/8	181	2-1/8	54	1/4	6.3	1-5/8	41	1-7/8	48	5-1/4	133	17/32	14	13/32	10
401-600	8	203	2-1/2	64	3/8	9.5	2	51	2-1/8	54	6	152	11/16	18	17/32	13

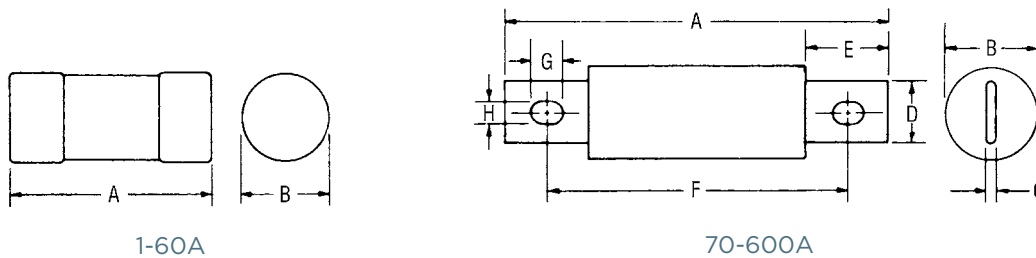

OPTIONAL INDICATOR/MICROSWITCH MOUNT (EI) DIMENSIONS:

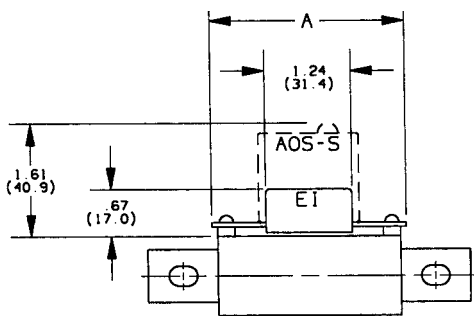

Note: Fuses with the EI option are designed to work with the AOS-S or AOS-Q add-on switch (ordered separately).



Catalog Number	A
AJT (70-100)-EI	2.8 in (71.0 mm)
AJT (110-200)-EI	3.22 in (81.8 mm)
AJT (225-400)-EI	3.24 in (82.2 mm)
AJT (450-600)-EI	3.61 in (91.8 mm)

AJT Reducer Fuses

Time Delay/Class J

UL/CSA LISTED POWER FUSES

DECREASE YOUR CURRENT RATING WITHOUT USING A FUSE REDUCER



AJT Reducer Fuses are a safe permanent solution for decreasing your current rating without using a Fuse Reducer accessory, which is designed for temporary use only. These special purpose UL Listed reduced rating Class J fuses provide the same trusted protection levels as a traditional AJT fuses, but in a larger body.

FEATURES/BENEFITS:

- Replaces traditional temporary-use only Fuse Reducer accessories
- Recommended for Arc Flash energy reduction
- Extremely current-limiting for low peak let-thru current
- Most current-limiting UL class fuse
- Time-delay for motor starting and transformer inrush
- High-visibility orange label gives instant brand recognition
- Metal-embossed date and catalog number for traceability and lasting identification
- Fiberglass body provides dimensional stability in harsh industrial settings
- High-grade silica filler ensures fast arc quenching
- Optional EI indicator/switch

HIGHLIGHTS:

- Class J Reduced Rating
- Arc Flash mitigating
- Highly current-limiting
- Time-delay
- DC ratings
- Optional mechanical indicator

RATINGS:

Volts: 600VAC, 500VDC

Amps: 125 to 200A (in 400A body), 250 to 400A (in 600A body)

IR: 200kA I.R. AC, 100kA I.R. DC (Self-certified for 600VAC, 300kA I.R., UL witnessed).

APPLICATIONS:

- Motor circuits
- Mains
- Feeders
- Branch circuits
- Lighting, heating & general loads
- Transformers
- Control panels
- Circuit breaker back-up
- Bus duct
- Load centers

Note: See motor fuse applications tables for additional information

APPROVALS:

AJT (1-600):

- UL Listed to standard 248-8 File E2137
- IEC 269-2-1



CATALOG NUMBERS (AMPS) RECOMMENDED FUSE BLOCKS WITH BOX CONNECTORS FOR AMP-TRAP® CLASS J FUSES

Catalog Numbers	Amp Rating	Body Size
AJT125/400	125A	400A
AJT150/400	150A	
AJT175/400	175A	
AJT200/400	200A	
AJT250/600	250A	600A
AJT300/600	300A	
AJT350/600	350A	
AJT400/600	400A	

Amp Rating/ Body Size	Catalog Number	
	600V or Less	
	1 Pole	3 Pole
125/400-200/400	64031J	64033J
250/600-400/600	6631J	6633J

A variety of pole configurations and termination provisions are available. Refer to Section FB for details.

DIMENSIONS

Ampere Rating	A		B		C		D		E		F		G		H	
	in	mm	in	mm	in	mm	in	mm	in	mm	in	mm	in	mm	in	mm
125-200	7-1/8	181	2-1/8	54	1/4	6.3	1-5/8	41	1-7/8	48	5-1/4	133	17/32	14	13/32	10
250-400	8	203	2-1/2	64	3/8	9.5	2	51	2-1/8	54	6	152	11/16	18	17/32	13

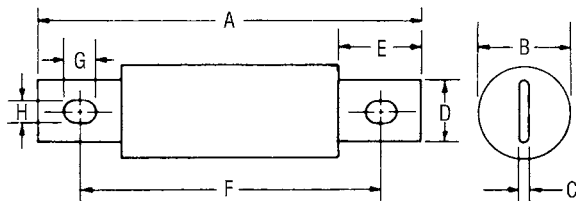

70-600A

HSJ

High Speed/Class J

UL/CSA LISTED POWER FUSES

PROTECT YOUR WIRING AND POWER
SEMICONDUCTORS WITH A SINGLE FUSE



The High Speed J (HSJ) fuse combines the low I^2t of a semiconductor fuse and the branch circuit performance of a Class J UL listed fuse. This fuse was designed for the starting characteristics of solid state motor controllers. The HSJ can provide branch circuit protection per NEC requirements, as well as very low I^2t for protection of power semiconductors such as Diodes, SCRs, GTOs and SSRs.

FEATURES/BENEFITS:

- Optimized over-load capability for withstanding elevated levels of current during electronic motor controller starts
- Low I^2t (low thermal energy)
- Excellent cycling ability for frequent starts/stops without nuisance opening

RATINGS:

- **Volts:** 600VAC, 500VDC
- **Amps:** 1 to 600A (AC), 15 to 600A (DC)
- **IR:** 200kA I.R. AC, 100kA I.R. DC, L/R =10mS or less (Self Certified for 600VAC, 300kA I.R., UL witnessed.)

HIGHLIGHTS:

- Current-limiting
- AC & DC ratings
- Low I^2t
- Compact size

APPLICATIONS:

- Branch circuits
- Control panels
- Electronic motor controllers
- Phase controllers
- Drives
- Soft-starters
- Solid state relays

APPROVALS:

- UL listed to standard 248-8 File E2137
- CSA certified to standard C22.2 no. 248.8
- DC listed to UL 248



CATALOG NUMBERS (AMPS)

HSJ1	HSJ30	HSJ90	HSJ250
HSJ3	HSJ35	HSJ100	HSJ300
HSJ6	HSJ40	HSJ110	HSJ350
HSJ10	HSJ45	HSJ125	HSJ400
HSJ15	HSJ50	HSJ150	HSJ450
HSJ17-1/2	HSJ60	HSJ175	HSJ500
HSJ20	HSJ70	HSJ200	HSJ600
HSJ25	HSJ80	HSJ225	

RECOMMENDED FUSE BLOCKS
WITH BOX CONNECTORS FOR
AMP-TRAP® CLASS J FUSES

Fuse Ampere Rating	Catalog Number 600V or Less	
	1-Pole	3-Pole
0-30	US3J1I	US3J3I
31-60	US6J1I	US6J3I
61-100	61036J	61038J
101-200	62001J	62003J
201-400	64031J	64033J
401-600	6631J	6633J

A variety of pole configurations and termination provisions are available. Refer to Section FB for details.

DIMENSIONS

Ampere Rating	A		B		C		D		E		F		G		H	
	in	mm	in	mm	in	mm	in	mm	in	mm	in	mm	in	mm	in	mm
1-30	2-1/4	57	13/16	21	-	-	-	-	-	-	-	-	-	-	-	-
31-60	2-3/8	60	1-1/16	27	-	-	-	-	-	-	-	-	-	-	-	-
61-100	4-4/8	117	1-1/8	29	1/8	3.2	3/4	19	1	25	3-5/8	92	3/8	10	9/32	7
101-200	5-3/4	146	1-5/8	41	3/16	4.8	1-1/8	29	1-3/8	35	4-3/8	111	3/8	10	9/32	7
201-400	7-1/8	181	2-1/8	54	1/4	6.3	1-5/8	41	1-7/8	48	5-1/4	133	17/32	13	13/32	10
401-600	8	203	2-1/2	64	3/8	9.5	2	51	2-1/8	54	6	152	11/16	18	17/32	13

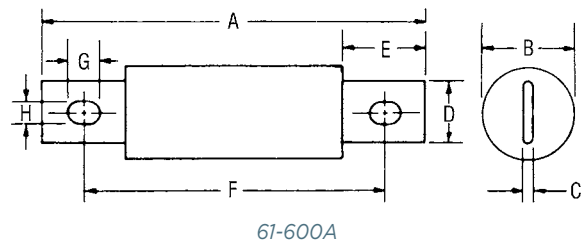
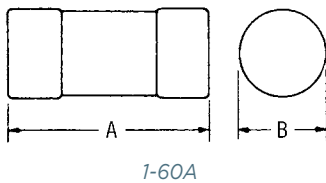

A4J

Fast Acting/Class J

UL/CSA LISTED POWER FUSES

FOR EXCELLENT CURRENT-LIMITING PROTECTION



A4J Class J fuses deliver excellent current-limiting protection to a wide variety of applications. Their unique dimensions prevent the substitution of other fuses with lower voltage ratings, interrupting ratings, or current-limiting capability.

FEATURES/BENEFITS:

- High current limitation for low peak let-thru current
- Unique dimensions prevent replacement by other fuse classes
- Fiberglass body provides dimensional stability in harsh industrial environments
- Easy-to-read imprint label for quick recognition and replacement

RATINGS:

- **Volts:** 600VAC, 300VDC
- **Amps:** 1 to 600A
- **IR:** 200kA I.R. AC, 100kA I.R. DC

HIGHLIGHTS:

- Fast-acting
- Very current-limiting
- DC ratings

APPLICATIONS:

- Capacitors
- Load centers
- Panelboards
- Switchboards
- Bus duct
- Feeder circuits
- Circuit breakers
- Lighting, heating, and general loads

APPROVALS:

- UL listed to standard 248-8 File E2137
- CSA certified to standard C22.2 no. 248.8
- DC listed to UL 248
- IEC 269-2-1



CATALOG NUMBERS (AMPS)

A4J1	A4J35	A4J90	A4J250
A4J3	A4J40	A4J100	A4J300
A4J6	A4J45	A4J110	A4J350
A4J10	A4J50	A4J125	A4J400
A4J15	A4J60	A4J150	A4J450
A4J20	A4J70	A4J175	A4J500
A4J25	A4J75	A4J200	A4J600
A4J30	A4J80	A4J225	

RECOMMENDED FUSE BLOCKS
WITH BOX CONNECTORS FOR
AMP-TRAP® CLASS J FUSES

Fuse Ampere Rating	Catalog Number 600V or Less	
	1-Pole	3-Pole
0-30	US3J1I	US3J3I
31-60	US6J1I	US6J3I
61-100	61036J	61038J
101-200	62001J	62003J
201-400	64031J	64033J
401-600	6631J	

A variety of pole configurations and termination provisions are available. Refer to Section FB for details.

DIMENSIONS

Ampere Rating	A		B		C		D		E		F		G		H	
	in	mm	in	mm	in	mm	in	mm	in	mm	in	mm	in	mm	in	mm
1-30	2-1/4	57	13/16	21	-	-	-	-	-	-	-	-	-	-	-	-
31-60	2-3/8	60	1-1/16	27	-	-	-	-	-	-	-	-	-	-	-	-
61-100	4-4/8	117	1-1/8	29	1/8	3.2	3/4	19	1	25	3-5/8	92	3/8	10	9/32	7
101-200	5-3/4	146	1-5/8	41	3/16	4.8	1-1/8	29	1-3/8	35	4-3/8	111	3/8	10	9/32	7
201-400	7-1/8	181	2-1/8	54	1/4	6.3	1-5/8	41	1-7/8	48	5-1/4	133	17/32	13	13/32	10
401-600	8	203	2-1/2	64	3/8	9.5	2	51	2-1/8	54	6	152	11/16	18	17/32	13

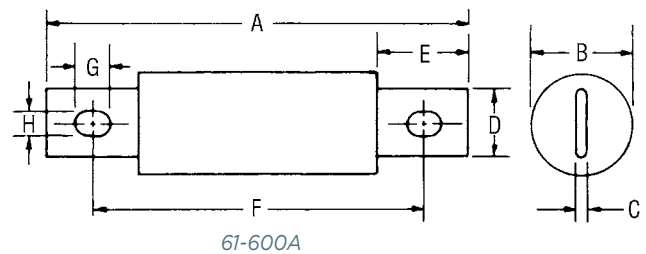
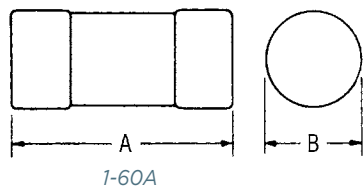

ATDR

Time Delay/Class CC

UL/CSA LISTED POWER FUSES

THE BEST PROTECTION FOR TODAY'S SMALL MOTORS



Amp-Trap 2000® ATDR small-dimension fuses can provide IEC Type 2 No Damage protection to your facility's increasingly sensitive branch circuit components and small motors - minimizing the risk of fault-related damage. ATDR Class CC fuses deliver the best time-delay characteristics in their class with excellent cycling ability for small motor loads.

FEATURES/BENEFITS:

- Time-delay for motor starting inrush currents without nuisance opening
- Highly current-limiting for low peak let-thru current
- Improved cycling ability for frequent motor starts/stops without nuisance fuse opening
- Rejection-style design prevents replacement errors (when used with recommended fuse blocks)
- High-visibility orange label ensures instant brand recognition, simplifies replacement
- Metal-embossed date and catalog number for traceability and lasting identification
- Fiberglass body provides dimensional stability in harsh industrial settings
- High-grade silica filler ensures fast arc quenching and optimum current-limitation

RATINGS:

Volts: 600VAC, 300VDC

Amps: 1/4 to 30A

IR: 200kA I.R. AC,
100kA I.R. DC

APPLICATIONS:

- Small motors
- Contactors
- Lighting, heating & general loads
- Branch circuit protection

Note: See motor fuse applications tables for more information

APPROVALS:

- UL listed to standard 248-4 File E2137
- CSA certified to standard C22.2 No. 248.4
- DC listed to UL standard 248



HIGHLIGHTS:

- Time-delay
- Best choice for small motor protection
- Highly current-limiting
- AC & DC rated

CATALOG NUMBERS (AMPS)

ATDR1/4	ATDR1-1/2	ATDR3	ATDR6	ATDR12
ATDR1/2	ATDR1-6/10	ATDR3-2/10	ATDR6-1/4	ATDR15
ATDR8/10	ATDR1-8/10	ATDR3-1/2	ATDR7	ATDR17-1/2
ATDR1	ATDR2	ATDR4	ATDR7-1/2	ATDR20
ATDR1-1/8	ATDR2-1/4	ATDR4-1/2	ATDR8	ATDR25
ATDR1-1/4	ATDR2-1/2	ATDR5	ATDR9	ATDR30
ATDR1-4/10	ATDR2-8/10	ATDR5-6/10	ATDR10	

RECOMMENDED FUSE BLOCKS FOR
CLASS CC FUSES

Number of Poles	Catalog Numbers			
	UltraSafe™ Indicating Fuse Holder	Screw Connector w/ Double Quick Connects	Pressure Plate Connector w/ Double Quick Connects	Copper Box Connector
ADDER		30310R	30320R	30350R
1	USCC1I	30311R	30321R	30351R
2	USCC2I	30312R	30322R	30352R
3	USCC3I	30313R	30323R	30353R
3	USFMCCI			

DIMENSIONS

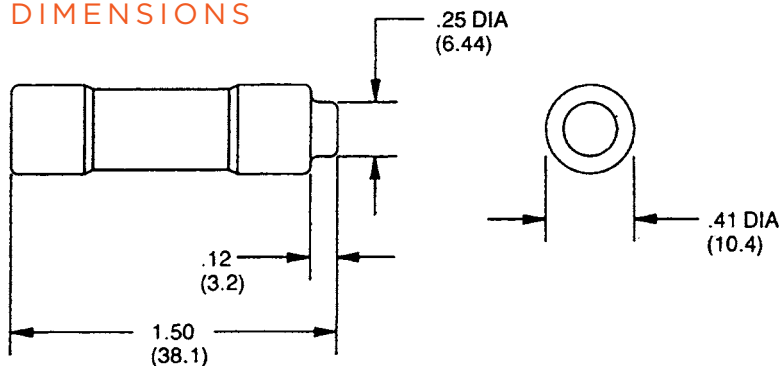

ATQR

Time Delay/Class CC

UL/CSA LISTED POWER FUSES

TAKE CONTROL OF FAULT CURRENTS HEADED FOR YOUR CONTROL TRANSFORMER



ATQR small-dimension fuses feature time-delay characteristics ideally suited for the high inrush currents of control transformers, solenoids, and similar inductive loads. Mersen's ATQR fuses provide superior protection for the branch circuits of electrical distribution systems.

FEATURES/BENEFITS:

- Time-delay for control transformer inrush loads without nuisance opening
- Highly current-limiting for low peak let-thru current
- Rejection-style design prevents replacement errors (when used with recommended fuse blocks)
- High visibility orange label ensures instant brand recognition, and simplifies replacement
- Metal-embossed date and catalog number for traceability and lasting identification
- Fiberglass body provides dimensional stability in harsh industrial settings
- High-grade silica filler ensures fast arc quenching and high current limitation

HIGHLIGHTS:

- Time-delay
- Best choice for small transformer protection
- Current-limiting

RATINGS:

Volts: 600VAC (1/10-30A),
300VDC (3-2/10 - 30A)

Amps: 1/10 to 30A

IR: 200kA I.R. AC, 100kA I.R. DC

APPLICATIONS:

- Control transformers
- Solenoids
- Inductive loads
- Lighting, heating & general-purpose loads

Note: See motor fuse applications tables for more information

APPROVALS:

- UL listed to standard 248-4 File E2137
- DC listed to UL standard 248
- CSA certified to standard C22.2 No. 248.4



CATALOG NUMBERS (AMPS)

ATOR1/10	ATOR8/10	ATOR2-8/10	ATOR7-1/2
ATOR1/8	ATOR1	ATOR3	ATOR8
ATOR3/16	ATOR1-1/8	ATOR3-2/10	ATOR9
ATOR2/10	ATOR1-1/4	ATOR3-1/2	ATOR10
ATOR1/4	ATOR1-4/10	ATOR4	ATOR12
ATOR3/10	ATOR1-1/2	ATOR4-1/2	ATOR15
ATOR4/10	ATOR1-6/10	ATOR5	ATOR17-1/2
ATOR1/2	ATOR1-8/10	ATOR5-6/10	ATOR20
ATOR6/10	ATOR2	ATOR6	ATOR25
ATOR3/4	ATOR2-1/4	ATOR6-1/4	ATOR30
	ATOR2-1/2	ATOR7	

RECOMMENDED FUSE BLOCKS
FOR CLASS CC FUSES

Number of Poles	Catalog Numbers			
	UltraSafe™ Indicating Fuse Holder	Screw Connector w/ Double Quick Connects	Pressure Plate Connector w/ Double Quick Connects	Copper Box Connector
ADDER		30310R	30320R	30350R
1	USCC1I	30311R	30321R	30351R
2	USCC2I	30312R	30322R	30352R
3	USCC3I	30313R	30323R	30353R
3	USFMCCI			

DIMENSIONS

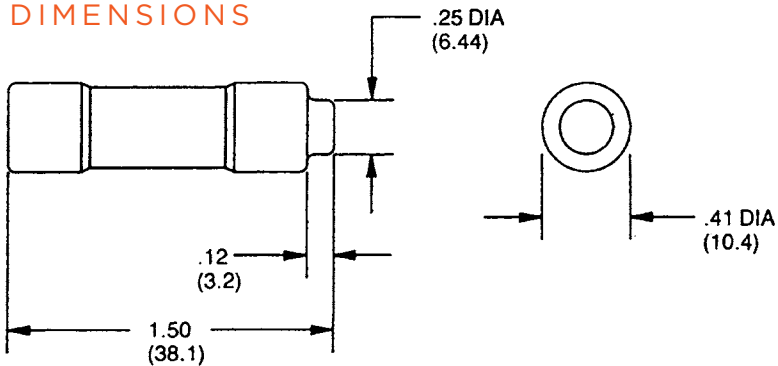

ATMR

Fast Acting/Class CC

UL/CSA LISTED POWER FUSES

SMALL FUSE - BIG PROTECTION
FOR GENERAL CIRCUITS



Amp-Trap® ATMR fuses, in the Class CC family, are the smallest dimension 600VAC/DC fuses suitable for branch circuit protection. The ATMR is a popular choice for economical protection of control circuits and control circuit transformers where available short circuit currents exceed 10,000 amperes. ATMR's rejection dimensions prevent substitution by lesser rated fuses. These fast acting fuses give current-limiting protection to general circuits.

CATALOG NUMBERS (AMPS) DIMENSIONS

ATMR1/10	ATMR1	ATMR4	ATMR10
ATMR1/8	ATMR1-1/4	ATMR5	ATMR12
ATMR2/10	ATMR1-1/2	ATMR6	ATMR15
ATMR1/4	ATMR2	ATMR7	ATMR20
ATMR3/10	ATMR2-1/2	ATMR8	ATMR25
ATMR1/2	ATMR3	ATMR9	ATMR30
ATMR3/4	ATMR3-1/2		

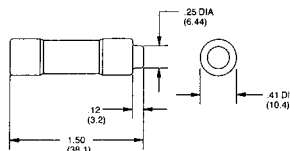

RECOMMENDED FUSE BLOCKS FOR AMP-TRAP® CLASS CC FUSES

Number of Poles	UltraSafe™ Indicating Fuse Holders	Screw Connector with Double Quick Connects	Pressure Plate Connector with Double Quick Connects	Cooper Box Connector
Adder	—	30310R	30320R	30350R
1	USCC1I	30311R	30321R	30351R
2	USCC2I	30312R	30322R	30352R
3	USCC3I	30313R	30323R	30353R
3	USFMCCI	—	—	—

A variety of pole configurations and termination provisions are available. Refer to Section FB for details.

RATINGS:

- **Volts:** 600VAC / DC
- **Amps:** 1/10 to 30A
- **IR:** 200kA I.R. AC, 100kA I.R. DC

HIGHLIGHTS:

- Fast-acting
- Very current-limiting

FEATURES/ BENEFITS:

- Rejection-style design prevents replacement errors when used with recommended fuse blocks
- Versatile design for individual component and branch circuit protection

APPLICATIONS:

- Control circuits
- Lighting
- General loads
- Branch circuit protection

APPROVALS:

- UL Listed to Standard 248-4 File E2137
- CSA Certified to Standard C22.2 No. 248.4
- DC listed to UL Standard 248



AG

Class G

UL/CSA LISTED POWER FUSES

AMP-TRAP® AG FUSES FIT RIGHT INTO A WIDE VARIETY OF INDUSTRIAL APPLICATIONS



The Mersen Amp-Trap AG fuse series is a complete line of Class G fuses. AG fuses safely fit a wide variety of applications. Class G fuses are made in four physical sizes and provide superior branch-circuit protection for lighting, heating, and appliance circuits.

FEATURES/BENEFITS:

- Four unique sizes from 1/2-60 amperes do not allow inter-changeability with other fuse classes
- Fiberglass bodies provide dimensional stability in harsh industrial settings

CATALOG NUMBERS (AMPS)

AG1/2	AG2	AG5	AG10	AG25	AG40	AG50
AG1	AG3	AG6	AG15	AG30	AG45	AG60
AG1-1/2	AG4	AG8	AG20	AG35		

DIMENSIONS

Ampere Rating	A		B		C	
	in	mm	in	mm	in	mm
1/2-15A	1.31	33.3	.406	10.3	.28	7.1
20A	1.41	35.8	.406	10.3	.28	7.1
25, 30A	1.62	41.2	.406	10.3	.28	7.1
35-60A	2.25	57.2	.406	10.3	.50	

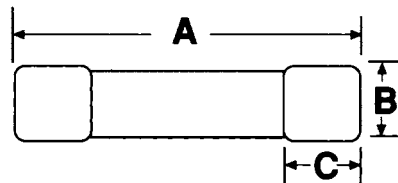

Cross Reference: AG will replace the following fuses: Bussmann SC, Littelfuse SLC

RATINGS:

- **Volts:** 600VAC (1/2 to 20A), 480VAC (25 to 60A)
- **Amps:** 1/2 to 60A
- **IR:** 100kA I.R. AC

HIGHLIGHTS:

- Current-limiting
- Time-delay (above 5A)

APPLICATIONS:

- Lighting
- Heating*
- Appliances

*except in Canada where fuses must be "P" or "D" type.

APPROVALS:

- UL listed to standard 248-5 File E2137
- CSA certified to standard C22.2 No. 248.5



OT/OTN/OTS

Class K-5

UL/CSA LISTED POWER FUSES

FOR VERSATILITY AND ECONOMY, THESE GENERAL PURPOSE FUSES ARE HARD TO BEAT



OT, OTN and OTS general purpose fuses provide low cost protection for feeder and branch circuits serving lighting, heating, and other non-motor loads. OT, OTN and OTS fuses will safely interrupt available short circuit currents up to 50,000 amperes in all ratings. OT, OTN and OTS fuses are not rejection fuses – care should be taken to ensure that replacement fuses do not have lower interrupting ratings than original fuses. OTN 15 through 60 satisfy the Canadian electrical code requirement for Type “P,” low melting-point, non-time-delay fuses.

FEATURES/BENEFITS:

- Easy to read imprint label for quick recognition and replacement
- Low cost for high protection value

APPLICATIONS:

- Feeders
- Branch circuits
- Resistive heating
- Residential and small commercial installations

RATINGS:

OT

- **Volts:** 250VAC / DC
- **Amps:** 1 to 600A
- **IR:** 50kA I.R. AC, 20kA I.R. DC

OTN (Canada)*

- **Volts:** 250VAC
- **Amps:** 15 to 60A
- **IR:** 50kA I.R. AC

OTS

- **Volts:** 600VAC / 300VDC
- **Amps:** 1 to 600A
- **IR:** 50kA I.R. AC, 20kA I.R. DC

HIGHLIGHTS:

- Versatile
- Lowest cost protection for circuits serving non-inductive loads

APPROVALS:

- UL Listed to Standard 248-9 File E2137
- CSA Certified to Standard C22.2 No. 248.9*
- Self-certified for DC per UL248



*The Canadian Electrical Code requires these fuses in ratings 15 through 60A to be of the low melting point design; use OTN 15-60.

CATALOG NUMBERS (AMPS)

250V			600V		
OT1	OT30, OTN30*	OT125	OTS1	OTS30	OTS125
OT2	OT35, OTN35*	OT150	OTS2	OTS35	OTS150
OT3	OT40, OTN40*	OT175	OTS3	OTS40	OTS175
OT4	OT45, OTN45*	OT200	OTS4	OTS45	OTS200
OT5	OT50, OTN50*	OT225	OTS5	OTS50	OTS225
OT6	OT60, OTN60*	OT250	OTS6	OTS60	OTS250
OT7	OT65	OT300	-	-	OTS300
OT8	OT70	OT350	OTS8	OTS70	OTS350
OT10	OT75	OT400	OTS10	OTS75	OTS400
OT12	OT80	OT450	OTS12	OTS80	OTS450
OT15, OTN15*	OT90	OT500	OTS15	OTS90	OTS500
OT20, OTN20*	OT100	OT600	OTS20	OTS100	OTS600
OT25, OTN25*	OT110		OTS25	OTS110	

* In Canada

RECOMMENDED FUSE BLOCKS
WITH BOX CONNECTORS FOR
ONE-TIME CLASS K-5 FUSES

Ampere Fuse Rating	Catalog Number			
	250V		600V	
	1-Pole	3-Pole	1-Pole	3-Pole
0-30	20306	20308	60306	60308
31-60	20606	20608	60606	60608
61-100	21036	21038	61036	61038
101-200	22001	22003	62001	62003
201-400	24001	24003	64001	64003
401-600	2631	2633	6631	6633

A variety of pole configurations and termination provisions are available. Refer to Section FB for details.

DIMENSIONS

Ampere Rating	A		B		C		D		E	
	in	mm	in	mm	in	mm	in	mm	in	mm
250V-OT, OTN Fuses										
0-30	2	51	9/16	14	-	-	-	-	-	-
31-60	3	76	13/16	21	-	-	-	-	-	-
61-100	5-7/8	149	1-1/16	27	1/8	3	3/4	19	1	25
101-200	7-1/8	181	1-9/16	40	3/16	5	1-1/8	28	1-3/8	35
201-400	8-5/8	219	2-1/16	53	1/4	6	1-5/8	41	1-7/8	48
401-600	10-3/8	264	2-9/16	66	1/4	6	2	51	2-1/4	57
600V-OTS Fuses										
0-30	5	127	13/16	21	-	-	-	-	-	-
31-60	5-1/2	139	1-1/16	27	-	-	-	-	-	-
61-100	7-7/8	200	1-5/16	34	1/8	3	3/4	19	1	25
101-200	9-5/8	244	1-13/16	46	3/16	5	1-1/8	28	1-3/8	35
201-400	11-5/8	295	2-9/16	66	1/4	6	1-5/8	41	1-7/8	48
401-600	13-3/8	340	3-1/8	80	1/4	6	2	51	2-1/4	57

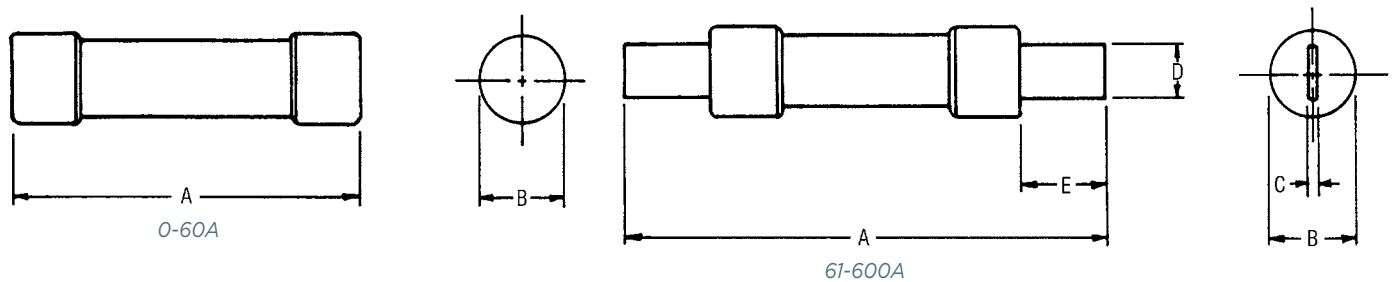

A3T & A6T

Fast Acting/Class T

UL/CSA LISTED POWER FUSES

THESE SMALL DIMENSION FUSES ARE
THE RIGHT FIT... FOR A TIGHT FIT



Fast-acting A3T and A6T Class T fuses combine two highly desirable features - high current limitation and a small physical size. Their unique dimensions prevent the substitution of other fuses with lower voltage ratings or current-limiting capability.

These fuses have glass melamine bodies for superior dimensional stability and catalog numbers stamped into the blades for permanent identification.

FEATURES/BENEFITS:

- Extremely current-limiting for low peak let-thru current
- Unique dimensions prevent replacement by other fuse classes
- Blade-stamped catalog numbers for permanent identification
- Small physical size for greater design flexibility

RATINGS:

A3T

- **Volts:** 300VAC / 160VDC
- **Amps:** 1 to 1200A
- **IR:** 200kA I.R. AC, 50kA I.R. DC

A6T

- **Volts:** 600VAC / 300VDC
- **Amps:** 1 to 800A
- **IR:** 200kA I.R. AC, 100kA I.R. DC

HIGHLIGHTS:

- Fast-acting
- Extremely current-limiting
- Small physical size
- DC ratings

APPLICATIONS:

- Loadcenters
- Panelboards
- Switchboards
- Circuit breakers
- Metering centers

APPROVALS:

- UL listed to standard 248-15 File E2137
- CSA certified to standard C22.2 no. 248.15
- DC listed to UL standard 248



CATALOG NUMBERS (AMPS)

300V			600V		
A3T1	A3T60	A3T300	A6T1	A6T60	A6T300
A3T3	A3T70	A3T350	A6T3	A6T70	A6T350
A3T6	A3T80	A3T400	A6T6	A6T80	A6T400
A3T10	A3T90	A3T450	A6T10	A6T90	A6T450
A3T15	A3T100	A3T500	A6T15	A6T100	A6T500
A3T20	A3T110	A3T600	A6T20	A6T110	A6T600
A3T25	A3T125	A3T700	A6T25	A6T125	A6T700
A3T30	A3T150	A3T800	A6T30	A6T150	A6T800
A3T35	A3T175	A3T1000	A6T35	A6T175	
A3T40	A3T200	A3T1200	A6T40	A6T200	
A3T45	A3T225		A6T45	A6T225	
A3T50	A3T250		A6T50	A6T250	

RECOMMENDED FUSE BLOCKS
WITH BOX CONNECTORS FOR
AMP-TRAP® CLASS T FUSES

Ampere Rating	Catalog Number			
	300V		600V	
	1-Pole	3-Pole	1-Pole	3-Pole
1-30	30306T	30308T	60306T	60308T
31-60	30606T	30608T	60606T	60608T
61-100	31001T	31003T	61031T	61033T
101-200	32031T	32033T	62031T	62033T
201-400	34031T	34033T	64031T	-
401-600	36031T	-	66031T	-

A variety of pole configurations and termination provisions are available. Refer to Section FB for details.

DIMENSIONS

Ampere Rating	A		B		C		D		E		F		G	
	in	mm	in	mm	in	mm	in	mm	in	mm	in	mm	in	mm
300V-A3T Fuses														
1-30	.88	22.4	.41	10.3	-	-	-	-	-	-	-	-	-	-
31-60	.88	22.4	.56	14.1	-	-	-	-	-	-	-	-	-	-
61-100	2.16	54.9	.81	20.6	.12	3.2	.75	19.0	1.56	39.6	.28	7.1	.82	20.8
101-200	2.44	62.0	1.06	26.9	.19	4.8	.88	22.4	1.70	43.2	.34	8.6	.83	21.1
201-400	2.75	69.8	1.33	33.8	.25	6.4	1.00	25.4	1.84	46.7	.41	10.4	.84	21.3
401-600	3.06	77.7	1.62	41.1	.31	7.8	1.25	31.8	2.03	51.6	.48	12.2	.84	21.3
601-800	3.38	85.8	2.08	52.8	.38	9.7	1.75	44.4	2.22	56.4	.55	14.0	.88	22.4
801-1200	4.00	102	2.52	64.0	.44	11.2	2.00	50.8	2.53	64.3	.61	15.5	1.03	26.2
600V-A6T Fuses														
1-30	1.50	38.1	.57	14.5	-	-	-	-	-	-	-	-	-	-
31-60	1.57	39.9	.81	20.6	1.51	38.4	1.00	25.4	-	-	-	-	-	-
61-100	2.95	75.0	.82	20.8	.12	3.2	.75	19.0	2.35	59.7	.28	7.1	1.58	40.1
101-200	3.26	82.8	1.07	27.2	.19	4.8	.88	22.4	2.51	63.7	.34	8.6	1.61	41.0
201-400	3.62	92.1	1.62	41.3	.25	6.4	1.00	25.4	2.72	69.1	.41	10.4	1.70	43.2
401-600	3.98	101.2	2.06	52.4	.31	7.9	1.25	31.8	2.95	75.0	.48	12.2	1.70	43.2
601-800	4.33	110.0	2.50	63.5	.37	9.5	1.75	44.4	3.17	80.5	.56	14.1	1.70	43.2

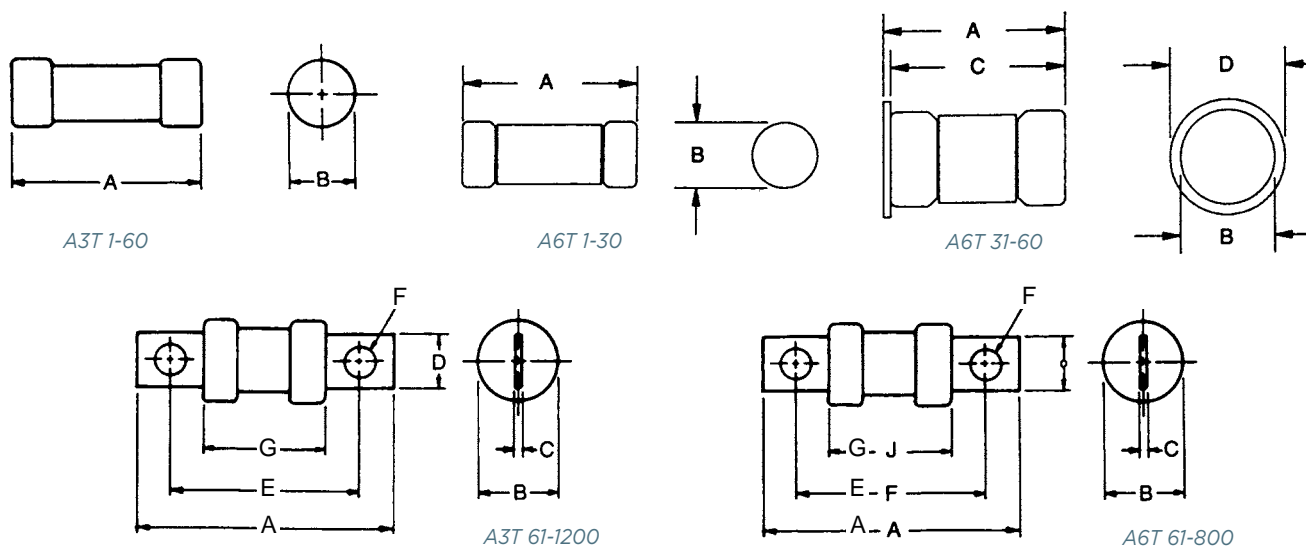

Class C

Canadian Fuses

UL/CSA LISTED POWER FUSES



Mersen Class C fuses have British standard (BS88) dimensions and are exact replacements for the British fuses and older HRCII-C fuses. Class C fuses are not dimensionally or electrically interchangeable with other North American fuses. They feature ceramic bodies and bolt-in mounting. They are for short-circuit protection only, in motor controllers, for example, where overload protection is provided by an overload relay.

* Ceramic version available upon request

HIGHLIGHTS:

- BS88 dimensions
- Fast-acting

APPLICATIONS:

- Short circuit and back-up protection of motor controllers and components

CATALOG NUMBERS (AMPS)

FES2	FES25	FES100	FESC100	FESF300	FESC350
FES4	FES30	FES125	FESC125	FESF350	FESC400
FES6	FES40	FES150	FESC150	FESF400	FESC450
FES10	FES50	FES200	FESC200	FESC250	FESC500
FES15	FES60	FESC80	FESF250	FESC300	FESC600
FES20	FES80				

RATINGS:

- **Volts:** 600VAC, 460VDC, 450VDC, 350VDC
- **Amps:** 2 to 600A
- **I.R.:** 200kA I.R. AC (2-600A), 40kA I.R. DC
- **460VDC:** FES (2-60A), FESF (250-400A), FESC (250-400A)
- **450VDC:** FESC (450-600A)
- **350VDC:** FES (80-100A), FESC (80-200A)

APPROVALS:

- CSA Certified HRCII-MISC IEC 269-2-1



CLASS C DIMENSIONS INCHES (MM)

Catalog No.	A	B	D	E	F	G	H	K
FES 2-30	2.06 (52.3)	0.81 (20.6)	3.31 (84.1)	0.35 (8.9)	0.06 (1.6)	2.83 (71.9)	0.20 (5.2)	0.84 (21.3)
FES 40-60	2.19 (55.6)	1.06 (26.9)	3.44 (87.4)	0.50 (12.7)	0.06 (1.6)	2.77 (70.4)	0.20 (5.2)	1.07 (27.2)
FES 80-100	2.69 (68.3)	1.34 (34.0)	4.31 (109.5)	0.75 (19.1)	0.13 (3.2)	3.64 (92.5)	0.34 (8.7)	1.43 (36.3)
FES 125-200	2.69 (68.3)	1.58 (40.1)	4.31 (109.5)	0.75 (19.1)	0.13 (3.2)	3.64 (92.5)	0.34 (8.7)	1.69 (42.9)
FESC 80-100	2.44 (61.9)	1.34 (33.9)	5.31 (134.9)	0.75 (19.1)	0.13 (3.2)	4.28 (108.7)		
FESC 125-200	2.44 (61.9)	1.59 (40.3)	5.31 (134.9)	0.75 (19.1)	0.13 (3.2)	4.28 (108.7)		
FESF 250-400	3.00 (76.2)	2.00 (50.8)	5.38 (136.7)	1.00 (25.4)	0.25 (6.4)	4.25 (108.0)	0.41 (10.4)	
FESC 250-400	3.00 (76.2)	2.00 (50.8)	8.25 (209.6)	1.00 (25.4)	0.25 (6.4)	5.16 (131.0)		
FESC 450-600	3.00 (76.2)	2.88 (73.0)	8.25 (209.6)	1.00 (25.4)	0.38 (9.5)	5.06 (128.6)		

FES2-30
FES40-60
FES80-100
FES125-200

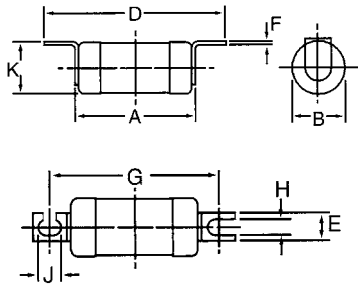

FESC80-100
FESC125-200
FESF250-400

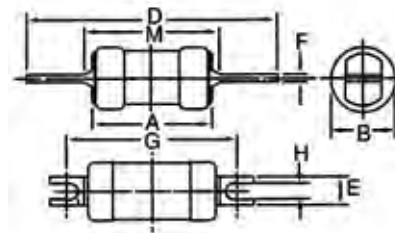

FESC250-400
FESC450-600

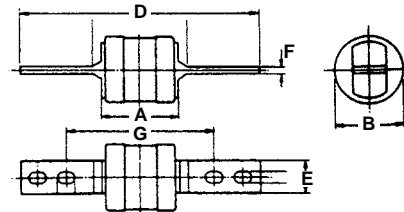

NRN/NRS Class H

Canadian Fuses

UL/CSA LISTED POWER FUSES

NON-TIME DELAY FUSES



Mersen NRN (250V) and NRS (600V) fuses are standard non-time delay fuses, with a 10kA short circuit rating. 250 Volt NRN15 through NRN60 fuses are certified as Type “P” fuses, satisfying the Canadian Electrical Code for low melting-point non-time delay fuses. Also qualifying for Type “P” are OTN15 through OTN60, which are Class K-5 fuses with a 50kA short circuit rating (found in the OT/OTS section of this catalog).

DIMENSIONS - INCHES (MM)

250V NRN Fuses					
Ampere Rating	A	B	C	D	E
1-30	2.00 (50.8)	0.56 (14.2)			0.50 (12.7)
35-60	3.00 (76.2)	0.81 (20.6)			0.63 (16.0)
70-100	5.88 (149)	1.06 (26.9)	0.13 (3.18)	0.75 (19.1)	1.00 (25.4)
110-200	7.13 (181)	1.63 (41.4)	0.19 (4.76)	1.13 (28.7)	1.38 (35.1)
225-400	8.63 (219)	2.13 (54.1)	0.25 (6.35)	1.63 (41.4)	1.88 (47.8)
450-600	10.4 (264)	2.63 (66.8)	0.25 (6.35)	2.00 (50.8)	2.25 (57.2)
600V NRS Fuses					
1-30	5.00 (127)	0.81 (20.6)			0.63 (16.0)
35-60	5.50 (139)	1.06 (26.9)			0.63 (16.0)
70-100	7.88 (200)	1.38 (35.1)	0.13 (3.18)	0.75 (19.1)	1.00 (25.4)
110-200	9.63 (244)	1.88 (47.8)	0.19 (4.76)	1.13 (28.7)	1.38 (35.1)
225-400	11.6 (295)	2.63 (66.8)	0.25 (6.35)	1.63 (41.4)	1.88 (47.8)
450-600	13.4 (340)	3.13 (79.5)	0.25 (6.35)	2.00 (50.8)	2.25 (57.2)

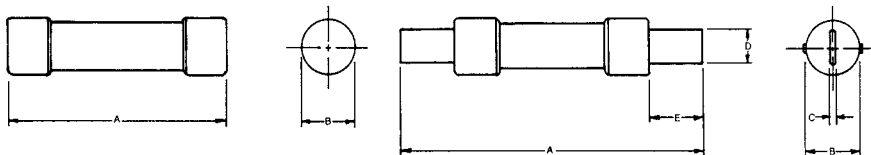

CATALOG NUMBERS

250V Fuse Ampere Ratings	
NRN1	NRN80
NRN2	NRN90
NRN3	NRN100
NRN4	NRN110
NRN5	NRN125
NRN6	NRN150
NRN10	NRN175
NRN15*	NRN200
NRN20*	NRN250
NRN25*	NRN250
NRN30*	NRN300
NRN35*	NRN350
NRN40*	NRN400
NRN45*	NRN450
NRN50*	NRN500
NRN60*	NRN600
NRN70	* CSA Type “P”
600V Fuse Ampere Ratings	
NRS1	NRS80
NRS2	NRS90
NRS3	NRS100
NRS4	NRS110
NRS5	NRS125
NRS6	NRS150
NRS10	NRS175
NRS15	NRS200
NRS20	NRS250
NRS25	NRS250
NRS30	NRS300
NRS35	NRS350
NRS40	NRS400
NRS45	NRS450
NRS50	NRS500
NRS60	NRS600
NRS70	

CRN/CRS Class H

Canadian Fuses

UL/CSA LISTED POWER FUSES

TIME DELAY FUSES



CRN & CRS TIME DELAY FUSES

Mersen CRN and CRS fuses are standard fuses, Type “D”, with 10kA short circuit rating. Type “D” fuses satisfy the Canadian Electrical Code requirement for low melting-point fuses.

DIMENSIONS - INCHES (MM)

250V CRN Fuses					
Ampere Rating	A	B	C	D	E
15-30	2.00 [50.8]	0.56 [14.2]			0.50 [12.7]
35-60	3.00 [76.2]	0.81 [20.6]			0.63 [16.0]
70-100	5.88 [149]	1.06 [26.9]	0.13 [3.18]	0.75 [19.1]	1.00 [25.4]
110-200	7.13 [181]	1.63 [41.4]	0.19 [4.76]	1.13 [28.7]	1.38 [35.1]
225-400	8.63 [219]	2.13 [54.1]	0.25 [6.35]	1.63 [41.4]	1.88 [47.8]
450-600	10.4 [264]	2.63 [66.8]	0.25 [6.35]	2.00 [50.8]	2.25 [57.2]
600V CRS Fuses					
15-30	5.00 [127]	0.81 [20.6]			0.63 [16.0]
35-60	5.50 [139]	1.06 [26.9]			0.63 [16.0]
70-100	7.88 [200]	1.38 [35.1]	0.13 [3.18]	0.75 [19.1]	1.00 [25.4]
110-200	9.63 [244]	1.88 [47.8]	0.19 [4.76]	1.13 [28.7]	1.38 [35.1]
225-400	11.6 [295]	2.63 [66.8]	0.25 [6.35]	1.63 [41.4]	1.88 [47.8]
450-600	13.4 [340]	3.13 [79.5]	0.25 [6.35]	2.00 [50.8]	2.25 [57.2]

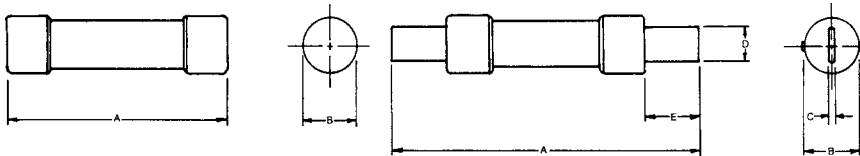

RATINGS:

CRN

- **Volts:** 250VAC
- **Amps:** 15 to 600A
- **I.R.:** 10kA I.R. AC

CRS

- **Volts:** 600VAC
- **Amps:** 15 to 600A
- **I.R.:** 10kA I.R. AC

APPROVALS:

- CSA Certified Type “D” 

CATALOG NUMBERS

250V Fuse Ampere Ratings*		
CRN15	CRN60	CRN200
CRN17-1/2	CRN70	CRN225
CRN20	CRN80	CRN250
CRN25	CRN90	CRN300
CRN30	CRN100	CRN350
CRN35	CRN110	CRN400
CRN40	CRN125	CRN450
CRN45	CRN150	CRN500
CRN50	CRN175	CRN600
* For 1/10 - 12A ratings use Tri-onic TR-R.		
600V Fuse Ampere Ratings**		
CRS15	CRS60	CRS200
CRS17-1/2	CRS70	CRS225
CRS20	CRS80	CRS250
CRS25	CRS90	CRS300
CRS30	CRS100	CRS350
CRS35	CRS110	CRS400
CRS40	CRS125	CRS450
CRS45	CRS150	CRS500
CRS50	CRS175	CRS600
** For 1/10 - 12 ratings use Tri-onic TRS-R.		

Fuse Pullers/Clip Clamps

CIRCUIT PROTECTION ACCESSORIES

PLASTIC FUSE PULLERS

Mersen plastic fuse pullers are fully insulated, made of high-dielectric, reinforced plastic with notched handles to provide a safe grip. Stronger and more durable than fiber pullers, they are permanently marked with the recommended fuse ampere range. Yellow color for safety.

Catalog No.	Description		Use with Fuses		
	Size	Length (in)	Ampere	Volts	Diameter (in)
34-001G	small	5	0-30	32-250	9/32-1/2
34-002G	pocket	7-1/2	0-100	250 600	-
34-003G	large	11-3/4	31-600 31-400	250 600	-

PLASTIC FUSE CLAMPS

Mersen fuse clip clamps are used to clamp fuse clips together onto a fuse ferrule or blade. An easy twist of the cap tightens the jaws against the clip, preventing heating by reducing resistance at the point where fuse and clip make contact. This helps prevent loss of spring tension due to annealing from overheating.

Catalog No.	Use with Fuse Clips			Weight (ounces)
	Type	Ampere	Volts	
32-001G	Ferrule	30	250	2
32-002G	Ferrule	60	250	
32-002G	Ferrule	30	600	
32-003G	Ferrule	60	600	
32-004G	knife blade	100	250	2
32-005G		200	or	2
32-006G*		400	600	8
32-007G		600		8

* Wide jaws permit clamping split clips.

NYLON FUSE PULLERS

Mersen nylon fuse pullers are fully insulated, made of high-dielectric, high impact nylon with no-slip handles and protective finger stops for greater safety when inserting fuses. Yellow color for safety.

Catalog No.	Description		Use with Fuses	
	Size	Length (in)	Ampere	Volts
34-015G	small	5	0-30	250
34-016G	medium	7-1/4	0-100 0-60	250 600

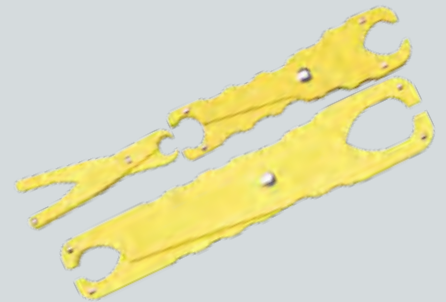



Your problem: As different as their job descriptions are on paper — today’s maintenance crews, specifying engineers, and OEM designers have one thing in common: They’re all working with smaller electrical system components. Be it motor starters, transformers, or circuit-control equipment. So, where do you turn for small dimension fuses without a reduction in protective capacity?

Our solution: Our international range of midget and miniature dimension and new PC mount fuses offers you all the protection you require. A wide range of ratings. Special characteristics like time-delay and low I^2t . All within a footprint of 1-1/2" x 13/32" or less.

Want more information fast? For more technical or application-specific information, please call our Midget and Miniature Dimension fuse experts at 978-465-4853 or visit our website at ep.mersen.com.

Midget, PC Mount & Miniature Fuses

**MAXIMUM
PROTECTION -
MINIMUM SPACE**

M
F

Midget

- ATQ Time-Delay MF 2
- ATM Fast-Acting MF 3
- TRM Time-Delay MF 4
- OTM Fast-Acting MF 5
- DCT Special Purpose MF 6
- FSM Multi-Meter Fuse MF 7
- GGU Fast-Acting MF 8
- GFN Indicating Time-Delay . . MF 9
- SBS Fast-Acting MF 10

PC Mount

- PCF, PCS, PCT MF 11

Miniature

- GSA/GSA-V MF 15
- GDL/GDL-V MF 16
- GGC/GGC-V, GGM/GGM-V . MF 17
- GGA/GGA-V, GSC/GSC-V . . MF 18
- GSB/GSB-V, GDG/GDG-V . . MF 19
- GSD/GSD-V, GSF/GSF-V . . MF 20
- GGX, GAB MF 21
- SMG/SMG-V, STG/STG-V . . MF 22
- MRF, MRT Radial Lead
Micro Fuses MF 23
- SFRT, SFRB, SFRG, FSFE,
SFRU In-Line Fuse Holders MF 24
- SLR, SMF, SHR In-Line Fuses
and Holders MF 25

MERSEN
Expertise, our source of energy

ATQ

Time-Delay Midget Fuses

MIDGET, PC MOUNT & MINIATURE FUSES

MF



Amp-Trap® ATQ midget time-delay fuses are rated a full 500 volts AC with 42 ampere ratings from 1/10 to 30A. They are an excellent choice for supplemental protection of circuits up to 30A where the available short circuit current does not exceed 10,000A. (Not for Branch Circuit Protection).

FEATURES/BENEFITS:

- Numerous ratings for a wide variety of applications up to 500VAC
- Time-delay (12 seconds at 200% rating) for circuits with high inrush current
- Can be used with UltraSafe™ Fuse holders
- 1 1/2" x 13/32" (10 mm x 38 mm) dimensions

CATALOG NUMBERS (AMPS)

ATQ1/10	ATQ3/10	ATQ1-1/8	ATQ2	ATQ3-2/10	ATQ6	ATQ12
ATQ1/8	ATQ4/10	ATQ1-1/4	ATQ2-1/8	ATQ3-1/2	ATQ6-1/4	ATQ14
ATQ15/100	ATQ1/2	ATQ1-4/10	ATQ2-1/4	ATQ4	ATQ7	ATQ15
ATQ3/16	ATQ6/10	ATQ1-1/2	ATQ2-1/2	ATQ4-1/2	ATQ8	ATQ20
ATQ2/10	ATQ8/10	ATQ1-6/10	ATQ2-8/10	ATQ5	ATQ9	ATQ25
ATQ1/4	ATQ1	ATQ1-8/10	ATQ3	ATQ5-6/10	ATQ10	ATQ30

RECOMMENDED FUSE BLOCKS for Midget (10x38mm) Fuses

Number of Poles	Catalog Number			
	UltraSafe™ Indicating Fuse Holder	Screw Connector	Pressure Plate Connector	Copper Box Connector
Adder		30310	30320	30350
1	USM1I	30311	30321	30351
2	USM2I	30312	30322	30352
3	USM3I	30313	30323	30353
3	USFM10I			

RATINGS:

- **Volts:** 500VAC
- **Amps:** 1/10 to 30A
- **I.R.:** 10kA I.R.

HIGHLIGHTS:

- Time-delay

APPLICATIONS:

- Supplemental protection of lighting, solenoid, motor and transformer circuits

APPROVALS:

- UL listed to standard 248-14 File E33925
- CSA Certified to Standard C22.2 No. 248.14



ATM

Fast-Acting Midget Fuses

MIDGET, PC MOUNT & MINIATURE FUSES

M
F



Amp-Trap® midget fast-acting ATM fuses are rated 600 volts AC and DC, with a 100kA interrupting rating. These ratings give the ATM a wide range of applications not covered by other midget fuses. In addition, ratings of 30/35, 30/40 and 30/50 amperes are offered for specific applications such as capacitor protection. These ATM fuses must still be considered 30A fuses because of their dimensions, but are able to withstand much higher inrush currents and tougher duty cycles. (Not for Branch Circuit Protection).

FEATURES/BENEFITS:

- For supplemental protection of small motors and transformers
- Extended ratings for special protection of capacitors and circuits with high inrush currents
- 600VDC ratings for a wide variety of applications including photovoltaic and solar applications.
- Can be used with UltraSafe™ fuse holders
- 1 1/2" x 13/32" (10mm x 38mm) dimensions

RECOMMENDED FUSE BLOCKS for Midget (10x38mm) Fuses

Number of Poles	Catalog Number			
	UltraSafe™ Indicating Fuse Holder	Screw Connector	Pressure Plate Connector	Copper Box Connector
Adder		30310	30320	30350
1	USM1I	30311	30321	30351
2	USM2I	30312	30322	30352
3	USM3I	30313	30323	30353
3	USFM10I			

RATINGS:

- **Volts:** 600VAC / DC
- **Amps:** 1/10 to 30A (35 to 50A AC only)
- **I.R.:** 100kA I.R.; 10kA I.R. AC (35 to 50A)

HIGHLIGHTS:

- Fast-acting
- Special Ratings (Above 30A)

APPLICATIONS:

- Supplemental protection of circuits up to 600VAC and 600VDC with 100kA I.R.

CATALOG NUMBERS (AMPS)

ATM1/10	ATM2	ATM12
ATM1/8	ATM3	ATM15
ATM2/10	ATM4	ATM20
ATM1/4	ATM5	ATM25
ATM1/2	ATM6	ATM30
ATM3/4	ATM7	ATM30/35*
ATM1	ATM8	ATM30/40*
ATM1-1/2	ATM10	ATM30/50*

* are not continuous current rated devices

APPROVALS:

- UL listed to standard 248-14 (1/10 to 30A) File E33925
- DC Listed to UL Standard 248-14 (1/10 to 30A)
- CSA Certified to Standard C22.2 No. 248.14 (1/10 to 30A)



TRM

Time-Delay Midget Fuses

MIDGET, PC MOUNT & MINIATURE FUSES

MF



Tri-Onic® TRM time-delay midget fuses are rated 250 volts AC and are offered in ampere ratings from 1/10 to 30A. They have 12 seconds time-delay at 200% rating to provide supplemental protection of small motors, small transformers and other high inrush loads, plus many other 250 volt applications. (Not for Branch Circuit Protection).

FEATURES/BENEFITS:

- Numerous ratings for a wide variety of applications
- 250VAC rating in all sizes up to 30A
- Time-delay for circuits with high inrush current
- Can be used with UltraSafe™ fuse holders
- 1 1/2" x 13/32" (10mm x 38mm) dimensions

CATALOG NUMBERS (AMPS)

TRM1/10	TRM4/10	TRM1-1/8	TRM2	TRM3-2/10	TRM5-6/10	TRM8	TRM15
TRM15/100	TRM1/2	TRM1-1/4	TRM2-1/4	TRM3-1/2	TRM6	TRM9	TRM20
TRM2/10	TRM6/10	TRM1-4/10	TRM2-1/2	TRM4	TRM6-1/4	TRM10	TRM25
TRM1/4	TRM8/10	TRM1-6/10	TRM2-8/10	TRM4-1/2	TRM7	TRM12	TRM30
TRM3/10	TRM1	TRM1-8/10	TRM3	TRM5			

RECOMMENDED FUSE BLOCKS for Midget (10x38mm) Fuses

Number of Poles	Catalog Number			
	UltraSafe™ Indicating Fuse Holder	Screw Connector	Pressure Plate Connector	Copper Box Connector
Adder		30310	30320	30350
1	USM1I	30311	30321	30351
2	USM2I	30312	30322	30352
3	USM3I	30313	30323	30353
3	USFM10I			

RATINGS:

- **Volts:** 250VAC
- **Amps:** 1/10 to 30A
- **I.R.:** 10kA I.R.

HIGHLIGHTS:

- Time-delay

APPLICATIONS:

- Small motors
- Small transformers
- Lighting circuits
- Control circuits

APPROVALS:

- UL listed to standard 248-14 File E33925
- CSA Certified to Standard C22.2 No. 248.14



OTM

Fast-Acting Midget Fuses

MIDGET, PC MOUNT & MINIATURE FUSES

M
F



One-time OTM midget fuses provide low-cost protection for 250 volt AC general purpose lighting, heating, control circuits, etc. where time-delay is not required. (Not for Branch Circuit Protection).

FEATURES/BENEFITS:

- Low cost and fully rated for economy without compromise
- Can be used with UltraSafe™ fuse holders
- 1 1/2" x 13/32" (10 mm x 38 mm) dimensions

CATALOG NUMBERS (AMPS)

OTM1	OTM3	OTM5	OTM8	OTM15	OTM25
OTM2	OTM4	OTM6	OTM10	OTM20	OTM30

RECOMMENDED FUSE BLOCKS for Midget (10x38mm) Fuses

Number of Poles	UltraSafe™ Indicating Fuse Holder	Catalog Number		
		Screw Connector	Pressure Plate Connector	Copper Box Connector
Adder		30310	30320	30350
1	USM1I	30311	30321	30351
2	USM2I	30312	30322	30352
3	USM3I	30313	30323	30353
3	USFM10I			

RATINGS:

- **Volts:** 250VAC
- **Amps:** 1 to 30A
- **I.R.:** 10kA I.R.

HIGHLIGHTS:

- Fast-acting

APPLICATIONS:

- Supplemental protection of circuits up to 250VAC and 10kA

APPROVALS:

- UL Listed to standard 248-14, File E33925
- CSA Certified to Standard C22.2 No. 248.14



DCT

Special Purpose Midget Fuses

MIDGET, PC MOUNT & MINIATURE FUSES



Mersen DCT fuses were developed to meet requirements coming from new applications such as protection of photovoltaic cells, multi meters and compact on board traction equipment for auxiliary circuits. This high performance DC fuse in its compact size offers multiple competitive advantages particularly for international applications where DC voltage requirements are above 600V DC.

FEATURES/BENEFITS:

- Low minimum breaking capacity (MBC)
- Compact size: 10 x 38 mm (13/32" x 1-1/2") size internationally accepted.
- Ferrule mount 1 to 30A for design versatility
- Can be used with UltraSafe™ fuse holders USM series
- 1 1/2" x 13/32" (10 mm x 38 mm) dimensions

APPLICATIONS:

- DC traction equipment
- Photovoltaic systems
- Multi-meters
- Semiconductor protection

RECOMMENDED FUSE BLOCKS for Midget (10x38mm) Fuses

Number of Poles	Catalog Number			
	UltraSafe™ Indicating Fuse Holder	Screw Connector	Pressure Plate Connector	Copper Box Connector
Adder		30310	30320	30350
1	USM1	30311	30321	30351
2	USM2	30312	30322	30352
3	USM3	30313	30323	30353

RATINGS:

- **Volts:** 750VAC, 1000VDC
- **Amps:** 1 to 30A
- **I.R.:** 100kA I.R. AC, 50kA I.R. DC
- **MBC:** 2.0 x I_n (AC); 1.3 x I_n (DC : 1 - 7A); 2.0 x I_n (DC : 8 - 30A)
- **L/R:** 1mS

HIGHLIGHTS:

- 750VAC / 1000VDC
- DC : L/R = 1mS

CATALOG NUMBERS

I²t (at 50,000 Amps -1000VDC
L/R = 1ms)

Catalog Number	Clearing I ² t (A ² s)	Watts Loss @ 80% Rating (W)	Watts Loss @ 100% Rating (W)
DCT1-2	-	0.2	0.32
DCT2-2	-	0.27	0.43
DCT3-2	-	0.9	1.4
DCT4-2	-	0.8	1.3
DCT5-2	-	0.9	1.4
DCT6-2	-	1.0	1.5
DCT7-2	-	1.1	1.5
DCT8-2	83	0.7	1.1
DCT10-2	127	0.9	1.5
DCT12-2	215	1.3	2.0
DCT15-2	495	1.9	3.0
DCT20-2	755	2.6	4.4
DCT25-2	970	2.9	5.3
DCT30-2	1650	3.0	5.8

APPROVALS:

- UL Recognized component File E60314



FSM

Multi-Meter Fuse

MIDGET, PC MOUNT & MINIATURE FUSES

MF



Mersen has developed a true 1000V AC/DC fuse designed to protect both analog and digital multi-meters. These fuses cover all the industry's multi-meter requirements in three easy to use amperage ratings. Good for 1000V AC and DC, the FSM line of Mersen fuses are designed for the power electronics metering and controls market.

FEATURES/BENEFITS:

- For the protection of multi-meters
- 1000V AC/DC for full range protection
- 100% Current rated for continuous current with L/R = 10mS carrying capability
- Glass melamine body and plated terminals provide superior reliability and performance

CATALOG NUMBERS (AMPS)

FSM44/100	FSM11	FSM15
-----------	-------	-------

DIMENSIONS

Catalog No.	A	B
FSM44/100	1.375"	0.406"
FSM11	1.500"	0.406"
FSM15	1.500"	0.406"

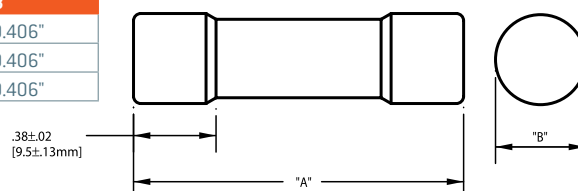

RATINGS:

- **Volts:** 1000VAC / DC
- **Amps:** 44/100A, 11A, 15A
- **I.R.:** 20kA I.R.

HIGHLIGHTS:

- Fast-acting
- Current-limiting

APPLICATIONS

- Multi-meters

CROSS REFERENCE

Mersen FSM replaces the:

- Bussmann: DMM-B
- Littelfuse: FLU

APPROVALS:

- UL Recognized component File E60314



GGU

Fast-Acting Midget Fuses

MIDGET, PC MOUNT & MINIATURE FUSES

MF



125 volt AC rated GGU fuses have midget fuse dimensions (1-1/2" long x 13/32" diameter). 20A-30A ratings have ceramic bodies, allowing use in higher ambient temperature conditions than other similar fuses. (Not for Branch Circuit Protection).

FEATURES/BENEFITS:

- Glass body on 1-15A makes status of fusible element clearly visible
- Ceramic body on 20-30A allows use in higher temperature applications
- Medium lag for protection of circuits up to 30A and 125VAC
- Can be used with UltraSafe™ fuse holders (1-30A)
- 1 1/2" x 13/32" (10 mm x 38 mm) dimensions

CATALOG NUMBERS (AMPS)

GGU1	GGU3	GGU5	GGU10	GGU30
GGU2	GGU4	GGU8	GGU20	

RECOMMENDED FUSE BLOCKS for Midget (10x38mm) Fuses

Number of Poles	Catalog Number			
	UltraSafe™ Indicating Fuse Holder	Screw Connector	Pressure Plate Connector	Copper Box Connector
Adder		30310	30320	30350
1	USM1I	30311	30321	30351
2	USM2I	30312	30322	30352
3	USM3I	30313	30323	30353
3	USFM10I			

RATINGS:

- **Volts:** 125VAC
- **Amps:** 1 to 30A
- **I.R.:** 10kA I.R.

HIGHLIGHTS:

- Fast-acting

APPROVALS:

- UL Listed 1-15A
- UL Recognized 20-30A



GFN

Time-Delay Midget Fuses

MIDGET, PC MOUNT & MINIATURE FUSES

MF



GFN midget indicating fuses are available in ratings from 1/10 through 30A. These time-delay fuses have built-in blown fuse indicators which pop out at the end of the fuse to visually indicate when the fuse has operated to open the circuit. Indicators may be used to trip a switch for remote as well as visual annunciation. (Not for Branch Circuit Protection).

FEATURES/BENEFITS:

- Pin indicator provides visual indication of open fuse or actuates switch for remote signaling
- Numerous ratings for a wide variety of applications
- 12 second time-delay at 200% rating
- Can be used with UltraSafe™ fuse holders (1/10 - 10A)
- 1 1/2" x 13/32" (10 mm x 38 mm) dimensions

CATALOG NUMBERS (AMPS)

GFN1/10	GFN4/10	GFN1-1/4	GFN2-1/4	GFN3-1/2	GFN6	GFN12*
GFN1/8	GFN1/2	GFN1-4/10	GFN2-1/2	GFN4	GFN6-1/4	GFN15*
GFN15/100	GFN6/10	GFN1-1/2	GFN2-8/10	GFN4-1/2	GFN7	GFN20*
GFN2/10	GFN8/10	GFN1-6/10	GFN3	GFN5	GFN8	GFN25*
GFN1/4	GFN1	GFN1-8/10	GFN3-2/10	GFN5-6/10	GFN10	GFN30*
GFN3/10	GFN1-1/8	GFN2	*Note: 12-30A is a double barrel fuse construction			

RECOMMENDED FUSE BLOCKS for Midget (10x38 mm) Fuses

Number of Poles	Catalog Number			
	UltraSafe™ Indicating Fuse Holder	Screw Connector	Pressure Plate Connector	Copper Box Connector
Adder		30310	30320	30350
1	USM1I	30311	30321	30351
2	USM2I	30312	30322	30352
3	USM3I	30313	30323	30353
3	USFM10I			

RATINGS:

- **Volts:** 250VAC (0.1 - 10A)
125VAC (12 - 15A)
32VAC (20 - 30A)
- **Amps:** 1/10 to 30A
- **I.R.:** 200kA I.R., 250VAC, 0.1-10A
10kA I.R., 125VAC, 0.1-15A
10kA I.R., 32VAC, 20-30A

HIGHLIGHTS:

- Pin indicator
- Time-delay
- 12-30A double body

APPLICATIONS:

- For supplemental protection of circuits where time-delay and blown fuse indication are required, such as solenoid circuits or control circuits.

APPROVALS:

- UL Listed to standard 248-14 (1/10 to 15A) File E33925
- CSA Certified to Standard C22.2 No. 248.14 (1/10 to 15A)



SBS

Fast-Acting Ferrule Fuses

MIDGET, PC MOUNT & MINIATURE FUSES

MF



Unique dimensions for today's smaller equipment and components. Fast-acting general purpose fuse developed in response to the industry's demand for smaller equipment and components. The only fuse in their size with a full 600 VAC rating for all ampere ratings by UL standard 248-14 and CSA No. 59.2, and are the only fuses of this size with an interrupting rating of 100kA RMS. SBS fuses are 1-3/8" long, smaller by 1/8" than most standard midget fuses and are available in 22 ampere ratings, from 2/10A to 30A. (Not for Branch Circuit Protection).

FEATURES/BENEFITS:

- Small unique physical size for maximum design flexibility and non-interchangeability with other fuse classes
- Fiberglass body provides dimensional stability in harsh industrial environments
- Can be used with UltraSafe™ fuse holder
- 1 3/8" x 13/32" dimensions

CATALOG NUMBERS (AMPS)

SBS2/10	SBS8/10	SBS1-8/10	SBS5	SBS10	SBS25
SBS4/10	SBS1	SBS2	SBS6	SBS12	SBS30
SBS1/2	SBS1-1/2	SBS3	SBS7	SBS15	
SBS3/4	SBS1-6/10	SBS4	SBS8	SBS20	

RATINGS:

- **Volts:** 600VAC
- **Amps:** 2/10 to 30A
- **I.R.:** 100kA I.R.

HIGHLIGHTS:

- Fast-acting
- Unique dimensions

APPLICATIONS:

- Control circuits
- Lighting ballasts
- Meter circuits
- Electronic circuits
- General purpose protection

CROSS REFERENCE:

SBS will replace Bussmann BBS, Littelfuse BLS fuses

APPROVALS:

- UL Listed to standard 248-14 File E33925
- CSA Certified to Standard C22.2 No. 248.14



PCF

Fast-Acting PC Mount Fuses

MIDGET, PC MOUNT & MINIATURE FUSES

FAST-ACTING FUSES FOR DIRECT MOUNTING ON PRINTED CIRCUIT BOARDS



Mersen's PCF series of fast-acting direct-mountable fuses addresses the increasing need for electrical protection at the PC board as current and voltage requirements push higher. These fuses help printed circuit board manufacturers reduce parts by eliminating clips and fuse blocks and allowing automated assembly. PCF fuses can be used for the protection of main frame power boards, small circuit breakers with low-interrupting ratings and other critical components. PCF fuses bring greatly-increased ampere, voltage and interrupting ratings to the board itself and are UL Component Recognized.

CATALOG NUMBERS (AMPS)

Slot Mount		Double Hole Mount		Surface Mount	
PCF1-R	PCF8-R	PCF1-H	PCF8-H	PCF1-S	PCF8-S
PCF2-R	PCF10-R	PCF2-H	PCF10-H	PCF2-S	PCF10-S
PCF3-R	PCF12-R	PCF3-H	PCF12-H	PCF3-S	PCF12-S
PCF4-R	PCF15-R	PCF4-H	PCF15-H	PCF4-S	PCF15-S
PCF5-R	PCF20-R	PCF5-H	PCF20-H	PCF5-S	PCF20-S
PCF6-R	PCF25-R	PCF6-H	PCF25-H	PCF6-S	PCF25-S
PCF7-R	PCF30-R	PCF7-H	PCF30-H	PCF7-S	PCF30-S
			PCF30/50-H		

Dimensions of the PCF Series are found on page C14

RATINGS:

- **Volts:** 600VAC / DC
- **Amps:** 1 to 30A
- **I.R.:** 100kA I.R.
- **L/R:** ≤10ms

HIGHLIGHTS:

- Fast-acting
- PC board mount
- Three mounting styles

APPLICATIONS:

- Protection of main frame power boards, circuit breakers, components

APPROVALS:

- UL Recognized Components File E60314



PCS

Semiconductor PC Mount Fuses

MIDGET, PC MOUNT & MINIATURE FUSES

SEMICONDUCTOR PROTECTION FUSES FOR DIRECT MOUNTING ON PRINTED CIRCUIT BOARDS

MF



Mersen's PCS series of extremely fast-acting, direct-mountable fuses address the increasing need for electrical protection at the PC board as current and voltage requirements push higher. These fuses help printed circuit board manufacturers reduce parts by eliminating clips and fuse blocks and allowing automated assembly. PCS fuses are AC and DC rated and are extremely current-limiting. They will protect semiconductors, main frame boards, circuit breakers with low interrupting rating and other critical components. PCS fuses bring I^2t protection, higher voltage and interrupting ratings to the board itself and are UL Component Recognized.

CATALOG NUMBERS (AMPS)

Slot Mount		Double Hole Mount		Surface Mount	
PCS5-R	PCS20-R	PCS5-H	PCS20-H	PCS5-S	PCS20-S
PCS8-R	PCS25-R	PCS8-H	PCS25-H	PCS8-S	PCS25-S
PCS10-R	PCS30-R	PCS10-H	PCS30-H	PCS10-S	PCS30-S
PCS12-R	PCS35-R	PCS12-H	PCS35-H	PCS12-S	PCS35-S
PCS15-R	PCS40-R	PCS15-H	PCS40-H	PCS15-S	PCS40-S

Dimensions of the PCS Series are found on page C14

WATTS LOSS DATA

Ampere Rating	Watts Loss @ 80% Rating (w)	Watts Loss @ 100% Rating (w)
5	0.5	0.7
10	0.9	1.5
15	1.9	3.0
20	2.6	4.4
25	2.9	5.3
30	3.0	5.8
35	3.3	6.4
40	3.6	7.0

RATINGS:

- **Volts:** 600VAC / DC
- **Amps:** 5 to 40A
- **I.R.:** 200kA I.R. AC; 100kA I.R. DC
- **L/R:** ≤10ms

HIGHLIGHTS:

- Extremely fast-acting
- PC board mount
- Three mounting styles

APPLICATIONS:

- Protection of semiconductors, circuit breakers, critical components

APPROVALS:

- UL Recognized Components File E60314



I²T DATA, 100KA

Ampere Rating	600VAC		600VDC L/R =10ms
	Melting I ² t (A ² s)	Clearing I ² t (A ² s)	Clearing I ² t (A ² s)
5	5	60	40
8	6.5	70	42
10	10	110	70
12	17	150	90
15	26	180	110
20	41	330	200
25	69	440	260
30	132	860	520
35	197	1300	780
40	276	1800	1100

PCT

Time-Delay PC Mount Fuses

MIDGET, PC MOUNT & MINIATURE FUSES

TIME-DELAY FUSES FOR DIRECT MOUNTING ON PRINTED CIRCUIT BOARDS

M
F



Mersen's PCT series of time-delay, direct-mountable fuses addresses the increasing need for electrical protection at the PC board as current and voltage requirements push higher. These fuses help printed circuit board manufacturers reduce parts by eliminating clips and fuse blocks and allowing automated assembly. PCT fuses can be used for the protection of main frame power boards, small circuit breakers with low interrupting ratings and other components. PCT fuses bring protection with time-delay, greatly increased ampere, voltage and interrupting ratings to the board itself and are UL Component Recognized.

CATALOG NUMBERS (AMPS)

Slot Mount		Double Hole Mount		Surface Mount	
PCT1-R	PCT8-R	PCT1-H	PCT8-H	PCT1-S	PCT8-S
PCT2-R	PCT10-R	PCT2-H	PCT10-H	PCT2-S	PCT10-S
PCT3-R	PCT12-R	PCT3-H	PCT12-H	PCT3-S	PCT12-S
PCT4-R	PCT15-R	PCT4-H	PCT15-H	PCT4-S	PCT15-S
PCT5-R	PCT20-R	PCT5-H	PCT20-H	PCT5-S	PCT20-S
PCT6-R	PCT25-R	PCT6-H	PCT25-H	PCT6-S	PCT25-S
PCT7-R	PCT30-R	PCT7-H	PCT30-H	PCT7-S	PCT30-S

Dimensions of the PCT Series are found on page C14

RATINGS:

- **Volts:** 500VAC
- **Amps:** 1 to 30A
- **I.R.:** 100kA I.R.

HIGHLIGHTS:

- Time-delay
- PC board mount
- Three mounting styles

APPLICATIONS:

- Protection of main frame power boards, circuit breakers, components

APPROVALS:

- UL Recognized Components File E60314



OUTLINE DIMENSIONS

Slot Mount (Rectangular Holes)

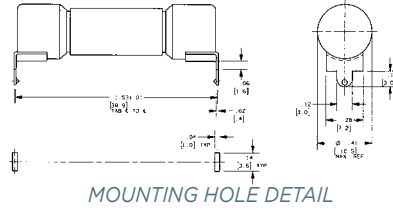

PCF1-R thru PCF30-R
PCS5-R thru PCS40-R
PCT1-R thru PCT30-R

FOR .062 (1.6) NOMINAL
CIRCUIT BOARD
THICKNESS

Double Hole Mount
(Round Holes)

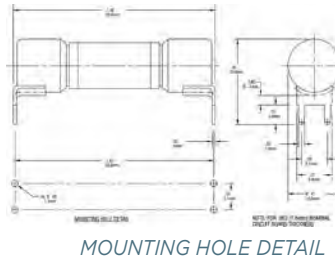

PCF1-H thru PCF30-H
PCS5-H thru PCS40-H
PCT1-H thru PCT30-H

FOR .062 (1.6) NOMINAL
CIRCUIT BOARD
THICKNESS

Surface (Screw) Mount

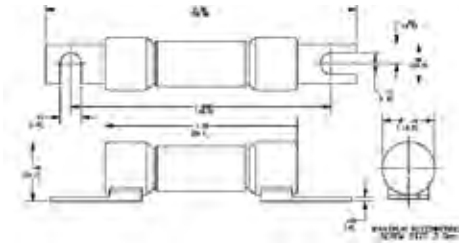

PCF1-S thru PCF30-S
PCS5-S thru PCS40-S
PCT1-S thru PCT30-S

MAXIMUM RECOMMENDED
SCREW SIZE 3.5MM

Electronic/Glass Fuses

MIDGET, PC MOUNT & MINIATURE FUSES



GSA/GSA-V

- Ceramic body
- Time-delay
- 1/4" x 1-1/4"
- 1-1/2" Axial leads optional

1/16A through 8A, 250VAC, UL Listed

10, 12, 15A, 250V UL Recognized

1/16A through 8A, 250VAC, CSA Certified

10, 12, 15A, 250V CSA Recognized

20A, 250VAC, 25 & 30A, 125VAC



STANDARD FUSE AMPERE RATINGS

Catalog Number	Axial Lead Cat. No	Ampere Rating	Volts	I.R.
GSA1/16	GSA-V1/16	1/16A	250V	1
GSA1/10	GSA-V1/10	1/10A	250V	1
GSA1/8	GSA-V1/8	1/8A	250V	1
GSA15/100	GSA-V15/100	15/100A	250V	1
GSA175/1000	GSA-V175/1000	175/1000A	250V	1
GSA3/16	GSA-V3/16	3/16A	250V	1
GSA2/10	GSA-V2/10	2/10A	250V	1
GSA1/4	GSA-V1/4	1/4A	250V	1
GSA3/10	GSA-V3/10	3/10A	250V	1
GSA3/8	GSA-V3/8	3/8A	250V	1
GSA4/10	GSA-V4/10	4/10A	250V	1
GSA1/2	GSA-V1/2	1/2A	250V	1
GSA6/10	GSA-V6/10	6/10A	250V	1
GSA7/10	GSA-V7/10	7/10A	250V	1
GSA3/4	GSA-V3/4	3/4A	250V	1
GSA8/10	GSA-V8/10	8/10A	250V	1
GSA1	GSA-V1	1A	250V	1
GSA1-1/4	GSA-V1-1/4	1-1/4A	250V	2
GSA1-1/2	GSA-V1-1/2	1-1/2A	250V	2
GSA1-6/10	GSA-V1-6/10	1-6/10A	250V	2
GSA2	GSA-V2	2A	250V	2
GSA2-1/4	GSA-V2-1/4	2-1/4A	250V	2
GSA2-1/2	GSA-V2-1/2	2-1/2A	250V	2
GSA2-8/10	GSA-V2-8/10	2-8/10A	250V	2
GSA3	GSA-V3	3A	250V	2
GSA3-2/10	GSA-V3-2/10	3-2/10A	250V	2
GSA3-1/2	GSA-V3-1/2	3-1/2A	250V	2
GSA4	GSA-V4	4A	250V	3
GSA5	GSA-V5	5A	250V	3
GSA6	GSA-V6	6A	250V	3
GSA6-1/4	GSA-V6-1/4	6-1/4A	250V	3
GSA7	GSA-V7	7A	250V	3
GSA8	GSA-V8	8A	250V	3
GSA10	GSA-V10	10A	250V	4
GSA12	GSA-V12	12A	250V	4
GSA15	GSA-V15	15A	250V	4
GSA20	GSA-V20	20A	250V	5
GSA25	GSA-V25	25A	125V	6
GSA30	GSA-V30	30A	125V	6

1. 250VAC @ 35A I.R./125VAC @ 10kA I.R.
2. 250VAC @ 100A I.R./125VAC @ 10kA I.R.
3. 250VAC @ 200A I.R./125VAC @ 10kA I.R.
4. 250VAC @ 750A I.R./125VAC @ 10kA I.R.
5. 250VAC @ 400A I.R./125VAC @ 10kA I.R.
6. 125VAC @ 400A I.R.

GDL/GDL-V

- Glass body
- Time-delay
- 1/4" x 1-1/4"
- 1-1/2" Axial leads optional



1/16A through 8A, 250VAC,
UL Listed and CSA Certified

10A through 15A, 125VAC,
UL Listed and CSA Certified

20A through 30A, 32VAC,
UL Listed to U.S. and Canadian safety standards



STANDARD FUSE AMPERE RATINGS

Catalog Number	Axial Lead Cat. No	Ampere Rating	Volts	I.R.
GDL1/16	GDL-V1/16	1/16A	250V	1
GDL1/10	GDL-V1/10	1/10A	250V	1
GDL1/8	GDL-V1/8	1/8A	250V	1
GDL15/100	GDL-V15/100	15/100A	250V	1
GDL175/1000	GDL-V175/1000	175/1000A	250V	1
GDL3/16	GDL-V3/16	3/16A	250V	1
GDL2/10	GDL-V2/10	2/10A	250V	1
GDL1/4	GDL-V1/4	1/4A	250V	1
GDL3/10	GDL-V3/10	3/10A	250V	1
GDL3/8	GDL-V3/8	3/8A	250V	1
GDL4/10	GDL-V4/10	4/10A	250V	1
GDL1/2	GDL-V1/2	1/2A	250V	1
GDL6/10	GDL-V6/10	6/10A	250V	1
GDL7/10	GDL-V7/10	7/10A	250V	1
GDL3/4	GDL-V3/4	3/4A	250V	1
GDL8/10	GDL-V8/10	8/10A	250V	1
GDL1	GDL-V1	1A	250V	1
GDL1-1/4	GDL-V1-1/4	1-1/4A	250V	2
GDL1-1/2	GDL-V1-1/2	1-1/2A	250V	2
GDL1-6/10	GDL-V1-6/10	1-6/10A	250V	2
GDL1-8/10	GDL-V1-8/10	1-8/10A	250V	2
GDL2	GDL-V2	2A	250V	2
GDL2-1/4	GDL-V2-1/4	2-1/4A	250V	2
GDL2-1/2	GDL-V2-1/2	2-1/2A	250V	2
GDL2-8/10	GDL-V2-8/10	2-8/10A	250V	2
GDL3	GDL-V3	3A	250V	2
GDL3-2/10	GDL-V3-2/10	3-2/10A	250V	2
GDL4	GDL-V4	4A	250V	3
GDL5	GDL-V5	5A	250V	3
GDL6	GDL-V6	6A	250V	3
GDL6-1/4	GDL-V6-1/4	6-1/4A	250V	3
GDL7	GDL-V7	7A	250V	3
GDL8	GDL-V8	8A	250V	3
GDL10	GDL-V10	10A	125V	4
GDL12	GDL-V12	12A	125V	4
GDL15	GDL-V15	15A	125V	4
GDL20	GDL-V20	20A	32V	5
GDL25	GDL-V25	25A	32V	5
GDL30	GDL-V30	30A	32V	5

1. 250VAC @ 35A I.R./125VAC @ 10kA I.R.
2. 250VAC @ 100A I.R./125VAC @ 10kA I.R.
3. 250VAC @ 200A I.R./125VAC @ 10kA I.R.
4. 125VAC @ 10kA I.R.
5. 32VAC @ 300A I.R.

GGC/GGC-V

- Glass body
- Fast-acting
- 1/4" x 1-1/4"
- 1-1/2" Axial leads optional

1/10A through 10A,
250VAC, UL Listed
and CSA Certified

12A and 15A, 125VAC,
UL Listed and CSA
Certified

20A through 30A, 32VAC



STANDARD FUSE
AMPERE RATINGS

Catalog Number	Axial Lead Cat. No	Ampere Rating	Volts	I.R.
GGC1/10	GGC-V1/10	1/10A	250V	2
GGC1/8	GGC-V1/8	1/8A	250V	2
GGC15/100	GGC-V15/100	15/100A	250V	2
GGC175/1000	GGC-V175/1000	175/1000A	250V	2
GGC3/16	GGC-V3/16	3/16A	250V	2
GGC2/10	GGC-V2/10	2/10A	250V	2
GGC1/4	GGC-V1/4	1/4A	250V	2
GGC3/10	N/A	3/10A	250V	2
GGC3/8	GGC-V3/8	3/8A	250V	2
GGC4/10	GGC-V4/10	4/10A	250V	2
GGC1/2	GGC-V1/2	1/2A	250V	2
GGC6/10	GGC-V6/10	6/10A	250V	2
GGC3/4	GGC-V3/4	3/4A	250V	2
GGC8/10	GGC-V8/10	8/10A	250V	2
GGC1	GGC-V1	1A	250V	2
GGC1-1/4	GGC-V1-1/4	1-1/4A	250V	2
GGC1-1/2	GGC-V1-1/2	1-1/2A	250V	2
GGC1-3/4	N/A	1-3/4A	250V	2
GGC1-6/10	GGC-V1-6/10	1-6/10A	250V	2
GGC2	GGC-V2	2A	250V	2
GGC2-1/4	GGC-V2-1/4	2-1/4A	250V	2
GGC2-1/2	GGC-V2-1/2	2-1/2A	250V	2
GGC3	GGC-V3	3A	250V	2
GGC3-2/10	GGC-V3-2/10	3-2/10A	250V	3
GGC4	GGC-V4	4A	250V	2
GGC5	GGC-V5	5A	250V	2
GGC6	GGC-V6	6A	250V	2
GGC6-3/10	GGC-V6-3/10	6-3/10A	250V	2
GGC7	GGC-V7	7A	250V	2
GGC7-1/2	N/A	7-1/2A	250V	2
GGC8	GGC-V8	8A	250V	2
GGC10	GGC-V10	10A	250V	2
GGC12	GGC-V12	12A	125V	4
GGC15	GGC-V15	15A	125V	4
GGC20	GGC-V20	20A	32V	5
GGC25	GGC-V25	25A	32V	5
GGC30	GGC-V30	30A	32V	5

2. 250VAC @ 200A I.R./125VAC @ 10kA I.R.
3. 250VAC @ 10kA I.R.
4. 125VAC @ 10kA I.R.
5. 32VAC @ 1000A I.R.

GGM/GGM-V

- Glass body
- Fast-acting
- 5 mm x 20 mm
- 1-1/2" Axial leads optional

1/16A through 3A,
250VAC, UL Listed and
CSA Certified

4A through 8A,
125VAC, UL Listed and CSA Certified

10A and 15A, 250VAC,
UL Recognized



STANDARD FUSE
AMPERE RATINGS

Catalog Number	Axial Lead Cat. No	Ampere Rating	Volts	I.R.
GGM1/16	GGM-V1/16	1/16A	250V	2
GGM1/10	GGM-V1/10	1/10A	250V	3
GGM1/8	GGM-V1/8	1/8A	250V	3
GGM2/10	GGM-V2/10	2/10A	250V	3
GGM1/4	GGM-V1/4	1/4A	250V	3
GGM3/10	GGM-V3/10	3/10A	250V	3
GGM4/10	GGM-V4/10	4/10A	250V	1
GGM1/2	GGM-V1/2	1/2A	250V	3
GGM6/10	GGM-V6/10	6/10A	250V	1
GGM7/10	GGM-V7/10	7/10A	250V	3
GGM3/4	GGM-V3/4	3/4A	250V	3
GGM8/10	GGM-V8/10	8/10A	250V	1
GGM1	GGM-V1	1A	250V	3
GGM1-2/10	N/A	1-2/10A	250V	2
GGM1-1/4	GGM-V1-1/4	1-1/4A	250V	3
GGM1-1/2	GGM-V1-1/2	1-1/2A	250V	3
GGM2	GGM-V2	2A	250V	3
GGM2-1/2	GGM-V2-1/2	2-1/2A	250V	3
GGM3	GGM-V3	3A	250V	3
GGM4	GGM-V4	4A	125V	4
GGM5	GGM-V5	5A	125V	4
GGM6	GGM-V6	6A	125V	4
GGM7	GGM-V7	7A	125V	4
GGM8	GGM-V8	8A	125V	4
GGM15	GGM-V15	15A	250V	5

1. 250VAC @ 35A I.R./125VAC @ 10kA I.R.
2. 250VAC @ 100A I.R./125VAC @ 10kA I.R.
3. 250VAC @ 200A I.R./125VAC @ 10kA I.R.
4. 125VAC @ 10kA I.R.
5. 250VAC @ 100A I.R.

MF

GGA/GGA-V

- Glass body
- Time-delay
- 5 mm x 20 mm
- 1-1/2" Axial leads optional



1/10 through 3A,
250VAC, UL Listed and
CSA Certified

4A and 5A, 125VAC,
UL Listed and CSA Certified



STANDARD FUSE AMPERE RATINGS

Catalog Number	Axial Lead Cat. No	Ampere Rating	Volts	I.R.
GGA1/10	GGA-V1/10	1/10A	250V	1
GGA1/8	GGA-V1/8	1/8A	250V	1
GGA2/10	GGA-V2/10	2/10A	250V	1
GGA1/4	GGA-V1/4	1/4A	250V	1
GGA3/10	GGA-V3/10	3/10A	250V	1
GGA4/10	GGA-V4/10	4/10A	250V	1
GGA1/2	GGA-V1/2	1/2A	250V	1
GGA6/10	GGA-V6/10	6/10A	250V	1
GGA7/10	GGA-V7/10	7/10A	250V	1
GGA3/4	GGA-V3/4	3/4A	250V	1
GGA8/10	GGA-V8/10	8/10A	250V	1
GGA1	GGA-V1	1A	250V	2
GGA1-1/4	GGA-V1-1/4	1-1/4A	250V	2
GGA1-1/2	GGA-V1-1/2	1-1/2A	250V	2
GGA1-6/10	GGA-V1-6/10	1-6/10A	250V	2
GGA2	GGA-V2	2A	250V	2
GGA2-1/2	GGA-V2-1/2	2-1/2A	250V	2
GGA3	GGA-V3	3A	250V	2
GGA4	GGA-V4	4A	125V	3
GGA5	GGA-V5	5A	125V	3

1. 250VAC @ 35A I.R./125VAC @ 10kA I.R.
2. 250VAC @ 100A I.R./125VAC @ 10kA I.R.
3. 125VAC @ 10kA I.R.

GSC/GSC-V

- Glass / ceramic body
- Time-delay
- 5 mm x 20 mm
- 1-1/2" Axial leads optional



1/10A through 3A,
250VAC, UL Listed
and CSA Certified

4A through 8A,
125VAC, UL Listed and CSA Certified

10A, 125VAC, UL and CSA Recognized



STANDARD FUSE AMPERE RATINGS

Catalog Number	Axial Lead Cat. No	Ampere Rating	Volts	I.R.
GSC1/10	GSC-V1/10	1/10A	250V	1
GSC1/8	GSC-V1/8	1/8A	250V	1
GSC1/4	GSC-V1/4	1/4A	250V	1
GSC3/10	GSC-3/10	3/10A	250V	1
GSC4/10	GSC-V4/10	4/10A	250V	1
GSC1/2	GSC-V1/2	1/2A	250V	1
GSC6/10	GSC-V6/10	6/10A	250V	1
GSC7/10	GSC-V7/10	7/10A	250V	1
GSC3/4	GSC-V3/4	3/4A	250V	1
GSC8/10	GSC-V8/10	8/10A	250V	1
GSC1	GSC-V1	1A	250V	1
GSC1-1/4	GSC-V1-1/4	1-1/4A	250V	1
GSC1-1/2	GSC-V1-1/2	1-1/2A	250V	1
GSC1-6/10	GSC-V1-6/10	1-6/10A	250V	1
GSC2	GSC-V2	2A	250V	1
GSC2-1/2	GSC-V2-1/2	2-1/2A	250V	1
GSC3	GSC-V3	3A	250V	1
GSC4	GSC-V4	4A	125V	2
GSC5	GSC-V5	5A	125V	2
GSC6	GSC-V6	6A	125V	2
GSC7	GSC-V7	7A	125V	2
GSC8	GSC-V8	8A	125V	2
GSC10		10A	125V	3

1. 250VAC @ 100A I.R./125VAC @ 10kA I.R.
2. 125VAC @ 10kA I.R.
3. 125VAC @ 1000A I.R.

GSB/GSB-V

- Glass body
- Fast-acting
- 5 mm x 20 mm
- 1-1/2" Axial leads optional

1/16A through 10A,
250VAC, UL and CSA
Recognized

1/16A through
6-3/10A, 250VAC, SEMKO Approved

1/16A through 6-3/10A, 250VAC, VDE Approved

IEC-127-2 Standard Sheet 2* 



GDG/GDG-V

- Glass body
- Time-delay
- 5 mm x 20 mm
- 1-1/2" Axial leads optional

1/16A through 10A,
250VAC, UL & CSA
Recognized

1/16A through
6-3/10A, 250VAC, SEMKO Approved

1/16A through 6-3/10A, 250VAC, VDE Approved

IEC 127-2 Standard Sheet 3* 



MF

STANDARD FUSE
AMPERE RATINGS

Catalog Number	Axial Lead Cat. No	Ampere Rating	Volts	I.R.
GSB1/16	GSB-V1/16	1/16A	250V	1
GSB8/100	GSB-V8/100	8/100A	250V	1
GSB1/10	GSB-V1/10	1/10A	250V	1
GSB1/8	GSB-V1/8	1/8A	250V	1
GSB16/100	GSB-V16/100	16/100A	250V	1
GSB2/10	GSB-V2/10	2/10A	250V	1
GSB1/4	GSB-V1/4	1/4A	250V	1
GSB315/1000	GSB-V315/1000	315/1000A	250V	1
GSB4/10	GSB-V4/10	4/10A	250V	1
GSB1/2	GSB-V1/2	1/2A	250V	1
GSB630/1000	GSB-V630/1000	630/1000A	250V	1
GSB8/10	GSB0-V8/10	8/10A	250V	1
GSB1	GSB-V1	1A	250V	1
GSB1-1/4	GSB-V1-1/4	1-1/4A	250V	1
GSB1-6/10	GSB-V1-6/10	1-6/10A	250V	1
GSB2	GSB-V2	2A	250V	1
GSB2-1/2	GSB-V2-1/2	2-1/2A	250V	1
GSB3-15/100	GSB-V3-15/100	3-15/100A	250V	1
GSB4	GSB-V4	4A	250V	2
GSB5	GSB-V5	5A	250V	3
GSB6-3/10	GSB-V6-3/10	6-3/10A	250V	4
GSB8	GSB-V8	8A	250V	5
GSB10	GSB-V10	10A	250V	6

1. 250VAC @ 35A I.R.
2. 250VAC @ 40A I.R.
3. 250VAC @ 50A I.R.
4. 250VAC @ 63A I.R.
5. 250VAC @ 80A I.R.
6. 250VAC @ 100A I.R.

*IEC Standards for 5x20 mm fuses do not include ratings above 6.3 amperes.

STANDARD FUSE
AMPERE RATINGS

Catalog Number	Axial Lead Cat. No	Ampere Rating	Volts	I.R.
GDG1/16	GDG-V1/16	1/16A	250V	1
GDG8/100	GDG-V8/100	8/100A	250V	1
GDG1/10	GDG-V1/10	1/10A	250V	1
GDG1/8	GDG-V1/8	1/8A	250V	1
GDG16/100	GDG-V16/100	16/100A	250V	1
GDG2/10	GDG-V2/10	2/10A	250V	1
GDG1/4	GDG-V1/4	1/4A	250V	1
GDG315/1000	GDG-V315/1000	315/1000A	250V	1
GDG4/10	GDG-V4/10	4/10A	250V	1
GDG1/2	GDG-V1/2	1/2A	250V	1
GDG630/1000	GDG-V630/1000	630/1000A	250V	1
GDG8/10	GDG-V8/10	8/10A	250V	1
GDG1	GDG-V1	1A	250V	1
GDG1-1/4	GDG-V1-1/4	1-1/4A	250V	1
GDG1-6/10	GDG-V1-6/10	1-6/10A	250V	1
GDG2	GDG-V2	2A	250V	1
GDG2-1/2	GDG-V2-1/2	2-1/2A	250V	1
GDG3-15/100	GDG-V3-15/100	3-15/100A	250V	1
GDG4	GDG-V4	4A	250V	2
GDG5	GDG-V5	5A	250V	3
GDG6-3/10	GDG-V6-3/10	6-3/10A	250V	4
GDG8	GDG-V8	8A	250V	5
GDG10	GDG-V10	10A	250V	6

1. 250VAC @ 35A I.R.
2. 250VAC @ 40A I.R.
3. 250VAC @ 50A I.R.
4. 250VAC @ 63A I.R.
5. 250VAC @ 80A I.R.
6. 250VAC @ 100A I.R.

*IEC Standards for 5x20 mm fuses do not include ratings above 6.3 amperes.

GSD/GSD-V

- Ceramic body
- Fast-acting
- 5 mm x 20 mm
- 1-1/2" Axial leads optional

1/16A through 10A, 250VAC,
UL & CSA Recognized

1A through 6-3/10A, 250 VAC,
SEMKO Approved

1A through 6-3/10A, 250 VAC, VDE Approved

IEC 127-2 Standard Sheet 1*



GSF/GSF-V

- Ceramic body
- Time-delay
- 5 mm x 20 mm
- 1-1/2" Axial leads optional

1/2A through 8/10A, 250VAC

1A through 6-3/10A, 250VAC,
SEMKO, VDE Approved

1A through 10A, 250VAC, UL and CSA Recognized

IEC-127-2 Standard Sheet 5*



STANDARD FUSE AMPERE RATINGS

Catalog Number	Axial Lead Cat. No	Ampere Rating	Volts	I.R.
GSD1/16	GSD-V1/16	1/16A	250V	1
GSD1/10	GSD-V1/10	1/10A	250V	1
GSD1/8	GSD-V1/8	1/8A	250V	1
GSD16/100	GSD-V16/100	16/100A	250V	1
GSD2/10	GSD-V2/10	2/10A	250V	1
GSD1/4	GSD-V1/4	1/4A	250V	1
GSD315/1000	GSD-V315/1000	315/1000A	250V	1
GSD4/10	GSD-V4/10	4/10A	250V	1
GSD1/2	GSD-V1/2	1/2A	250V	1
GSD630/1000	GSD-V630/1000	630/1000A	250V	1
GSD8/10	GSD-V8/10	8/10A	250V	1
GSD1	GSD-V1	1A	250V	1
GSD1-1/4	GSD-V1-1/4	1-1/4A	250V	1
GSD1-6/10	GSD-V1-6/10	1-6/10A	250V	1
GSD2	GSD-V2	2A	250V	1
GSD2-1/2	GSD-V2-1/2	2-1/2A	250V	1
GSD3-15/100	GSD-V3-15/100	3-15/100A	250V	1
GSD4	GSD-V4	4A	250V	1
GSD5	GSD-V5	5A	250V	1
GSD6-3/10	GSD-V6-3/10	6-3/10A	250V	1
GSD8	GSD-V8	8A	250V	1
GSD10	GSD-V10	10A	250V	1

1. 250VAC @ 1500A I.R.

*IEC Standards for 5x20 mm fuses do not include ratings above 6.3 amperes.

STANDARD FUSE AMPERE RATINGS

Catalog Number	Axial Lead Cat. No	Ampere Rating	Volts	I.R.
GSF1/2	GSF-V1/2	1/2A	250V	1
GSF630/1000	GSF-V630/1000	630/1000A	250V	1
GSF8/10	GSF-V8/10	8/10A	250V	1
GSF1	GSF-V1	1A	250V	1
GSF1-1/4	GSF-V1-1/4	1-1/4A	250V	1
GSF1-6/10	GSF-V1-6/10	1-6/10A	250V	1
GSF2	GSF-V2	2A	250V	1
GSF2-1/2	GSF-V2-1/2	2-1/2A	250V	1
GSF3-15/100	GSF-V3-15/100	3-15/100A	250V	1
GSF4	GSF-V4	4A	250V	1
GSF5	GSF-V5	5A	250V	1
GSF6-3/10	GSF-V6-3/10	6-3/10A	250V	1
GSF8	GSF-V8	8A	250V	1
GSF10	GSF-V10	10A	250V	1

1. 250VAC @ 1500A I.R.

*IEC Standards for 5x20 mm fuses do not include ratings above 6.3 amperes.

GGX

- Glass body
- Fast-acting
- 1/4" x 1"

1/2A through 2 1/2A, 250VAC,
UL Listed

3A through 7A, 125V AC, UL Recognized

8A through 30A, 32V AC, UL Recognized



GAB

- Ceramic body
- Fast-acting
- 1/4" x 1-1/4"

1/8A through 15A, 250VAC,
UL Listed and CSA Certified

20A through 30A, 250/125VAC,
UL Recognized



M
F



STANDARD FUSE
AMPERE RATINGS

Catalog Number	Ampere Rating	Volts	I.R.
GGX1/2	1/2A	250V	1
GGX3/4	3/4A	250V	1
GGX1	1A	250V	1
GGX1-1/2	1-1/2A	250V	2
GGX2	2A	250V	2
GGX2-1/2	2-1/2A	250V	3
GGX3	3A	125V	3
GGX4	4A	125V	3
GGX5	5A	125V	3
GGX6	6A	125V	3
GGX7	7A	125V	3
GGX8	8A	32V	4
GGX10	10A	32V	4
GGX12	12A	32V	4
GGX15	15A	32V	4
GGX20	20A	32V	4
GGX25	25A	32V	4
GGX30	30A	32V	4

1. 250VAC @ 35A I.R./125VAC @ 10kA I.R.
2. 250VAC @ 100A I.R./125VAC @ 10kA I.R.
3. 125VAC @ 10kA I.R.
4. 32VAC

STANDARD FUSE
AMPERE RATINGS

Catalog Number	Ampere Rating	Volts	I.R.
GAB1/8	1/8A	250V	1
GAB1/4	1/4A	250V	1
GAB3/8	3/8A	250V	1
GAB1/2	1/2A	250V	1
GAB3/4	3/4A	250V	1
GAB1	1A	250V	1
GAB2	2A	250V	2
GAB2-1/2	2-1/2A	250V	2
GAB3	3A	250V	2
GAB4	4A	250V	3
GAB5	5A	250V	3
GAB6	6A	250V	3
GAB7	7A	250V	3
GAB8	8A	250V	3
GAB10	10A	250V	3
GAB12	12A	250V	4
GAB15	15A	250V	4
GAB20	20A	250V	5
GAB25	25A	125V	6
GAB30	30A	125V	6

1. 250VAC @ 35A I.R./125VAC @ 10kA I.R.
2. 250VAC @ 100A I.R./125VAC @ 10kA I.R.
3. 250VAC @ 200A I.R./125VAC @ 10kA I.R.
4. 250VAC @ 750A I.R./125VAC @ 10kA I.R.
5. 250V/125VAC @ 400A I.R.
6. 125VAC @ 400kA I.R.

SMG/SMG-V

- Glass body
- Fast-acting
- 1-1/2" Axial leads optional



1/10A & 3/8A, 250VAC, UL Listed CSA Certified

1/8A through 7A, 350VAC, UL and CSA Recognized

8A & 10A, 125VAC



STANDARD FUSE AMPERE RATINGS

Catalog Number	Axial Lead Cat. No	Ampere Rating	Volts	I.R.	Size
SMG1/8	SMG-V1/8	1/8A	350V	2	B
SMG1/4	SMG-V1/4	1/4A	350V	2	B
SMG1/2	SMG-V1/2	1/2A	350V	2	B
SMG3/4	SMG-V3/4	3/4A	350V	2	B
SMG1	SMG-V1	1A	350V	2	B
SMG1-1/2	SMG-V1-1/2	1-1/2A	350V	2	B
SMG2	SMG-V2	2A	350V	2	B
SMG2-1/2	SMG-V2-1/2	2-1/2A	350V	2	B
SMG3	SMG-V3	3A	350V	2	B
SMG3-1/2	SMG-V3-1/2	3-1/2A	350V	2	B
SMG4	SMG-V4	4A	350V	2	B
SMG5	SMG-V5	5A	350V	2	B
SMG6	SMG-V6	6A	350V	2	B
SMG7	SMG-V7	7A	350V	2	B
SMG8	SMG-V8	8A	125V	3	A
SMG10	SMG-V10	10A	125V	3	A

1. 250VAC @ 35A I.R./125VAC @ 10kA I.R.
2. 350VAC @ 100A I.R./140VDC @ 150A I.R./125VAC @ 10kA I.R.
3. 125VAC @ 10kA I.R.

STG/STG-V

- Glass body
- Time-delay
- 1-1/2" Axial leads optional



3/8A 250VAC, UL Listed and CSA Certified

1/4A through 7A, 350VAC, UL and CSA Recognized



STANDARD FUSE AMPERE RATINGS

Catalog Number	Axial Lead Cat. No	Ampere Rating	Volts	I.R.	Size
STG1/4	STG-V1/4	1/4A	350V	2	B
STG3/8	STG-V3/8	3/8A	250V	1	A&C
STG1/2	STG-V1/2	1/2A	350V	2	B
STG6/10	STG-V6/10	6/10A	350V	2	B
STG3/4	STG-V3/4	3/4A	350V	2	B
STG8/10	STG-V8/10	8/10A	350V	2	B
STG1	STG-V1	1A	350V	2	B
STG1-1/4	STG-V1-1/4	1-1/4A	350V	2	B
STG1-1/2	STG-V1-1/2	1-1/2A	350V	2	B
STG2	STG-V2	2A	350V	2	B
STG2-1/2	STG-V2-1/2	2-1/2A	350V	2	B
STG3	STG-V3	3A	350V	2	B
STG3-1/2	STG-V3-1/2	3-1/2A	350V	2	B
STG4	STG-V4	4A	350V	2	B
STG5	STG-V5	5A	350V	2	B
STG6	STG-V6	6A	350V	2	B
STG7	STG-V7	7A	350V	2	B

1. 250VAC @ 35A I.R./125VAC @ 10kA I.R.
2. 350VAC @ 100A I.R./140VDC @ 150A I.R./125VAC @ 10kA I.R.

Size	Non-lead		With leads		
	A	B	A	B (Insulated Caps)	C
Length (mm)	14.5 +/- 0.75	13.8 +/- 0.5	15.2 +/- 0.75	18 +/- 0.2	14.48
Diameter (mm)	4.6 +/- 0.1	5.1 +/- 0.1	5.5 +/- 0.2	6.2 +/- 0.2	4.7

MRF, MRT

Radial Lead Micro Fuses

MIDGET, PC MOUNT & MINIATURE FUSES

MRF

- Fast-acting microfuse

Thermoplastic body and cap, UL 94-V0

Pins are tin-lead plated copper alloy

Approvals: VDE, MITI, CE, UL Recognized, CSA Accepted

50mA to 6.3A, 250VAC - UL Recognized and CSA Accepted



MRT

- Time-delay microfuse

Thermoplastic body and cap, UL 94-V0

Pins are tin-lead plated copper alloy

Approvals: SEMCO, VDE, MITI, CE, UL Recognized, CSA Accepted

80mA to 6.3A, 250VAC - UL Recognized and CSA Accepted



STANDARD FUSE AMPERE RATINGS

Catalog Number	Ampere Rating	Volts	Fuse Length
MRF50	50mA	250V	1
MRF63	63mA	250V	1
MRF80	80mA	250V	1
MRF100	100mA	250V	1
MRF125	125mA	250V	1
MRF160	160mA	250V	1
MRF200	200mA	250V	1
MRF250	250mA	250V	1
MRF315	315mA	250V	1
MRF400	400mA	250V	1
MRF500	500mA	250V	1
MRF630	630mA	250V	1
MRF800	800mA	250V	1
MRF1	1A	250V	1
MRF1.25	1.25A	250V	1
MRF1.6	1.6A	250V	1
MRF2	2A	250V	1
MRF2.5	2.5A	250V	1
MRF3.15	3.15A	250V	1
MRF4	4A	250V	1
MRF5	5A	250V	1
MRF6.3	6.3A	250V	1

1. 250VAC @ 50A I.R.

STANDARD FUSE AMPERE RATINGS

Catalog Number	Ampere Rating	Volts	Fuse Length
MRT80	80mA	250V	1
MRT100	100mA	250V	1
MRT125	125mA	250V	1
MRT160	160mA	250V	1
MRT200	200mA	250V	1
MRT250	250mA	250V	1
MRT315	315mA	250V	1
MRT400	400mA	250V	1
MRT500	500mA	250V	1
MRT630	630mA	250V	1
MRT800	800mA	250V	1
MRT1	1A	250V	1
MRT1.25	1.25A	250V	1
MRT1.6	1.6A	250V	1
MRT2	2A	250V	1
MRT2.5	2.5A	250V	1
MRT3.15	3.15A	250V	1
MRT4	4A	250V	1
MRT5	5A	250V	1
MRT6.3	6.3A	250V	1

1. 250VAC @ 50A I.R.

SFRT, SFRB, SFRG, SFRU, FSFE

In-Line Fuse Holders

MIDGET, PC MOUNT & MINIATURE FUSES

SFRT

- Twist-lock
- In-line fuse holders for FSFE fuses.
- Used at 32V or less with fuses rated up to 20A when proper spring for fuse size is installed.



STANDARD FUSE AMPERE RATINGS

Catalog Number*	Fuse Installed
SFRT4	FSFE4
SFRT6	FSFE6
SFRT7-1/2	FSFE7-1/2
SFRT9	FSFE9
SFRT14	FSFE14
SFRT20	FSFE20

*Includes FSFE fuse

SFRB

- Bayonet knob
- In-line fuse holders for FSFE fuses.
- Used at 32V or less with fuses rated up to 20A when proper spring for fuse size is installed.



STANDARD FUSE AMPERE RATINGS

Catalog Number*	Fuse Installed
SFRT4	FSFE4
SFRT6	FSFE6
SFRT7-1/2	FSFE7-1/2
SFRT9	FSFE9
SFRT14	FSFE14
SFRT20	FSFE20

*Includes FSFE fuse

SFRG

- In-line fuse holder for 5 x 20 mm fuses.
- Max. current rating for 5x20mm fuses - 10A @ 32V



SFRU

Universal in-line fuse holder - supplied with 15" loop of #14 AWG red vinyl insulated wire frame and three springs in different lengths to accommodate FSFE size fuses.



FSFE

- Glass body
- Fast-acting



4A through 30A, 32VAC/DC - UL Listed



STANDARD FUSE AMPERE RATINGS

Catalog Number	Ampere Rating	Volts	Fuse Length
FSFE4	4A	32V	5/8"
FSFE6	6A	32V	3/4"
FSFE7-1/2	7-1/2A	32V	7/8"
FSFE9	9A	32V	7/8"
FSFE14	14A	32V	1-1/16"
FSFE20	20A	32V	1-1/4"
FSFE30	30A	32V	1-7/16"

SLR, SMF, SHR

In-Line Fuses and Holders

MIDGET, PC MOUNT & MINIATURE FUSES

M
F

SLR FUSES RATINGS:

- **Volts:**
300VAC
- **Amps:**
1/2 to 15A
- **I.R.:** 10kA I.R.

APPROVALS:

- UL Listed
File No. E10480
CSA Certified



HIGHLIGHTS:

- Fast-acting
- Integral fuse & insulating cap

SMF FUSES RATINGS:

- **Volts:**
300VAC
- **Amps:**
3/10 to 10A
- **I.R.:** 10kA I.R.

APPROVALS:

- UL Listed
File No. E10480
CSA Certified



HIGHLIGHTS:

- Time-delay
- Integral fuse & insulating cap
- Designed specifically to handle ballast inrush currents

SHR FUSE HOLDERS RATINGS:

- **Volts:**
300VAC
- **Amps:** 15A
- **Withstand Rating:** 10kA I.R.
- **Dielectric Strength:** 2,000V

APPROVALS:

- UL Recognized
Component Guide
IZLT2, UL File
No. E52283



HIGHLIGHTS:

- Superior wire retention
- Thermoplastic insulator - 150° C RTI
- Single and two wire versions
- Two load plug-in ports available
- Integral mounting clip 0.062" thick panel
- Integral wire retention clip to hold #18 wire
- Tin plated, insulated #18 solid copper wire leads, 6" length



Mersen SLR and SMF in-line fuses are used to protect fluorescent lighting fixtures and ballasts. The SLR is a fast-acting fuse. SMF is a time-delay fuse. Both used to protect individual 300V fixtures. Mersen's SHR fuse holder has an integral clip for panel mounting to meet this requirement. The holder fits into a standard 7/8" knock-out or keyhole punch that provides anti-rotation. The SHR is available in a single or double wire version. The single wire version (SHR-1) allows insertion of #18 AWG ballast leads directly into the holder.

CATALOG NUMBERS

Ampere Rating	Catalog Numbers	
300mA		SMF3/10
500mA	SLR1/2	SMF1/2
600mA		SMF6/10
800mA		SMF8/10
1A	SLR1	S MF1
1-1/4A		SMF1-1/4
1-1/2A	SLR1-1/2	
1-6/10A	SLR1-6/10	SMF1-6/10
2A	SLR2	SMF2
2-1/2A	SLR2-1/2	SMF2-1/2
2-8/10A		SMF2-8/10
3A	SLR3	SMF3
3-2/10A		SMF3-2/10
4A	SLR4	SMF4
5A	SLR5	SMF5
6A	SLR6	
6 1/4A		SMF 6 1/4
7A	SLR7	SMF7
8A	SLR8	SMF8
9A	SLR9	
10A	SLR10	SMF10
12A	SLR12	
15A	SLR15	

FUSE HOLDERS

Single Wire	Two Wire
SHR-1	SHR

Note: Both holders are compatible with all fluorescent light fuses

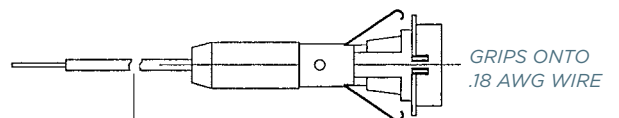
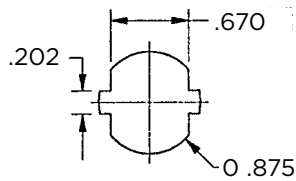
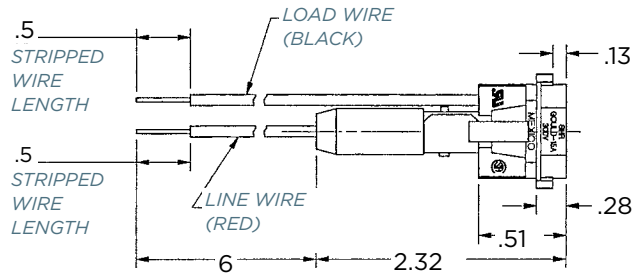
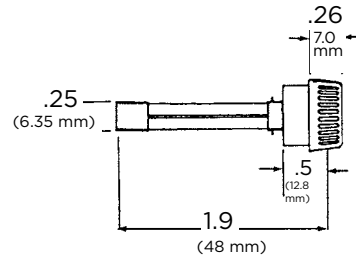

Note: SHR-1, LINE WIRE ONLY

MF



Your problem: On one hand you need current limiting protection for medium voltage transformers and distribution systems that supply industrial plants, shopping centers, hospitals, schools, office buildings and underground residential service. On the other, you need high short-circuit current protection to avoid damages to busway, motors, switches and other equipment.

Our solution: Current-limiting power fuses are widely used in these applications because they afford excellent over-current protection and noiseless operation, and because they can be used in confined spaces. The amount of damage in the faulted area and the mechanical stress and strain on busway, switches and other apparatus carrying the fault current is proportional to the square of the current and to the length of time the fault persists. By limiting the let through energy at the fault, properly applied current-limiting fuses assist in limiting or preventing short-circuit damage to busway, circuit breakers, switches, and other electrical components. Current-limiting power fuses are manufactured in ratings ranging from 1kV through 38kV and in continuous current ratings from 0.5 amperes through 1200 amperes. Various designs are available for use with motors, transformers, capacitors, and circuit-protection equipment.

Want more information fast? For more technical or application-specific information, please call our Medium Voltage experts at 978-465-4853 or visit our website at ep.mersen.com.

Medium Voltage Fuses

**VARIOUS TYPES -
DIFFERENT
CONFIGURATIONS -
MANY RATINGS -
ONE SOLUTION**

Transformer Protection

- Amp-Trap® CS-3 and 9F60/9F62 Series MV 2
- Amp-Trap® & 9F62 Bolt-In Series MV 12
- Amp-Trap® CL-14 Series MV 19

Motor Protection

- Amp-Trap® & 9F60 Series MV 23
- Amp-Trap® Bolt-in Series MV 29
- Amp-Trap® DIN-style Series MV 34

Potential Transformer Protection

- Amp-Trap® & 9F60 Series PT Fuses MV 36

Capacitor Protection

- Amp-Trap® & 9F60 Series MV 40



Transformer Protection

Amp-Trap® CS-3 Series and 9F60/9F62 Series

MEDIUM VOLTAGE FUSES

2.75kV, 5.5kV, 8.25kV, 15.5kV, 25.8kV AND 38kV
FERRULE MOUNTED FUSES

M
V



Mersen fuses for the protection of transformers and distribution lines deliver overload and short circuit protection. These current-limiting fuses will melt at current that can be as low as 1.7 times the fuse current ratings up to its maximum interrupting rating. These fuses are designed to withstand the transformer magnetizing inrush current. They have 2 (size C), 3 (size D) and 4 (size E) inch diameter barrels with ferrules and are mounted in spring reinforced clips.

FEATURES/BENEFITS:

- Amp-Trap CS-3 and 9F62 series are UL listed for compatibility with UL listed equipment.
- Ferrule mounting for standard clips and interchangeability with other brands of fuses.
- Current-limiting for superior equipment protection.
- Non-venting for silent operation.
- Metal embossed catalog number and manufacturing date for lasting identification.
- Outdoor usage for the 9F62 and 9F60 type EJO.
- Blown-fuse indicator to give positive identification of open fuse:
 - Amp-Trap: 2" Barrel 1 lb tripped force - 0.19 Inch
 - Amp-Trap: 3" Barrel 2 lb tripped force - 0.50 Inch
 - 9F60/9F62: 0.125 lb tripped force - 0.20 Inch
- Accessories - see Section FB

RATINGS

- See next page for listing

HIGHLIGHTS:

- E-Rated
- UL listed
- Outdoor use



APPLICATIONS:

- Protection for 2.4kV to 34.5kV transformers or distribution systems.

APPROVALS:

- Some UL listed to standard File E143362



DEFINITIONS:

General Purpose Current-Limiting Fuses (Per IEEE Std C37.41-2016):

A general purpose current-limiting fuse is one that is capable of interrupting all currents, from its rated maximum interrupting current down to a low value equal to the current that causes melting of the fuse elements in one hour or more, under specified conditions.

E-Rating: E-Rated fuses perate as follows (Per IEEE C37.42-2016):

- 100E or less - must melt in 300 seconds (5 mins.) at 200 to 240% of E (ampere) rating.
- Over 100E - must melt in 600 seconds (10 mins.) at 220 to 264% of E (ampere) rating.
- Example: A 100E fuse must melt in 300 seconds with an applied current of 200 to 240 amperes.

Power Distribution Fuses:

Defines fuses designed prior to the time where the ANSI standards defined the term “General Purpose” and do not meet all of the general purpose definition. These fuses are capable of interrupting all currents above 2.2 to 3 times the fuse’s rated current up to its maximum interrupting rating.

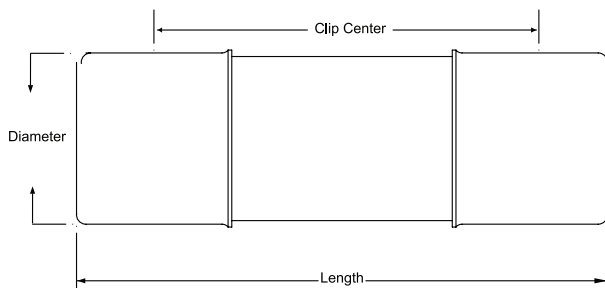

FERRULE MOUNTED FUSES

Amp-Trap CS-3 Series: (Indoors or outdoors in a weatherproof enclosure)

A055F: 5.5kV - AC: 5E to 450E - 63kA I.R. Sym

A825X: 8.25kV - AC: 10E to 200E - 70kA I.R. Sym

A155F: 15.5kV - AC: 5E to 200E - 50 kA I.R. Sym

9F62 Series Type EJO-1: (Indoors and outdoors, to 80kA)

9F62: 5.5kV - AC: 25A to 450A - 50kA IR Sym

9F62: 8.3kV - AC: 20A to 250A - 50 kA IR Sym

9F62: 15.5kV - AC: 20A to 200A - 50 kA IR Sym



9F60 Series Type EJO-1: (Indoors and outdoors)

9F60: 2.75kV - AC: 1E to 200E - 50kA IR Sym

9F60: 5.5kV - AC: 0.5E to 200E - 50kA IR Sym

9F60: 8.25kV - AC: 0.5E to 200E - 50kA IR Sym

9F60: 15.5kV - AC: 0.5E to 100E - 50kA to 120kA IR Sym

9F60: 25.8kV - AC: 0.5E to 100E - 25kA to 35kA IR Sym

9F60: 38kV - AC: 1E to 80E - 13kA to 26kA IR Sym



9F60 Series Type EJ-1: (Indoors or outdoors in a weatherproof enclosure)

9F60: 2.75kV - AC: 1E to 200E - 47kA to 52kA IR Sym

9F60: 5.5kV - AC: 0.5E to 25E - 63kA IR Sym

9F60: 15.5kV - AC: 2E to 175E - 31kA to 82kA IR Sym

9F60: 25.8kV - AC: 0.5E to 2E - 35kA IR Sym

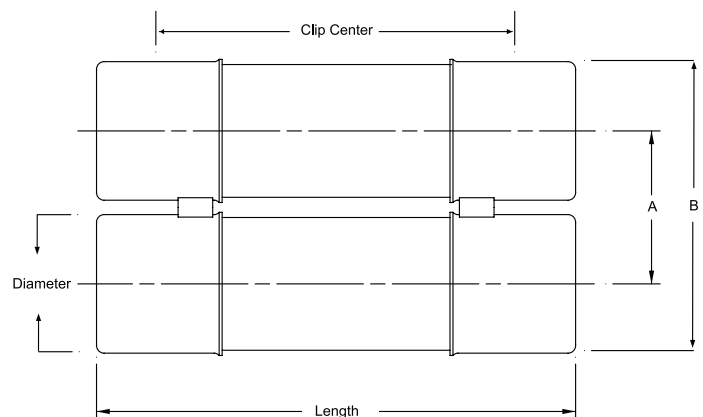

9F series A = 3.31 inches (84mm)

9F series B = 6.16 inches (160mm)

Amp-Trap series A = 3.63 inches (92 mm)

Amp-Trap series B = 6.63 inches (169 mm)



2.75kV FERRULE MOUNTED FUSES:

2.75kV Power Distribution fuses - 9F60 series, E-Rated EJ-1

7" (178 mm) Clip Centers - Suitable for use indoors or in an enclosure only

Catalog No.	Amp Rating	No. of Barrels	Indicating	Diameter Inches (mm)	Length Inches (mm)	Max Voltage	Max IR RMS Sym	Fuse Support Indoor (EK-1)	Fuse Support Outdoor (EKO-1)	Fuse Disconnect Indoor (EK-3)	Fuse Disconnect Outdoor (EKO-3)
9F60CCB001	1E	1	Yes	2 (50.8)	9.18 (233)	2.75 kV	47kA	9F61AAB201	N/A	9F61AAB205	N/A
9F60CCB002	2E										
9F60CCB003	3E										
9F60CCB005	5E										
9F60CCB007	7E										
9F60CCB010	10E										
9F60CCB015	15E	1	Yes	2 (50.8)	9.18 (233)	2.75 kV	52kA	9F61AAB201	N/A	9F61AAB205	N/A
9F60CCB020	20E										
9F60CCB025	25E										
9F60ECB030	30E										
9F60ECB040	40E										
9F60ECB050	50E										
9F60ECB065	65E	1	Yes	3 (76.2)	10.88 (276)	2.75 kV	52kA	9F61AAB301	N/A	9F61AAB305	N/A
9F60ECB080	80E										
9F60ECB100	100E										
9F60GCB125	125E										
9F60GCB150	150E										
9F60GCB200	200E										
		2	Yes	3 (76.2)	10.88 (276)	2.75 kV	52kA	9F61AAB401	N/A	9F61AAB405	N/A

2.75kV Power Distribution fuses - 9F60 series, E-Rated EJ-1

9" (229 mm) Clip Centers - Suitable for use indoors or in an enclosure only

Catalog No.	Amp Rating	No. of Barrels	Indicating	Diameter Inches (mm)	Length Inches (mm)	Max Voltage	Max IR RMS Sym	Fuse Support Indoor (EK-1)	Fuse Support Outdoor (EKO-1)	Fuse Disconnect Indoor (EK-3)	Fuse Disconnect Outdoor (EKO-3)
9F60CEB001	1E	1	Yes	2 (50.8)	11.18 (284)	2.75 kV	52kA	9F61ACB201	N/A	9F61ACB205	N/A
9F60CEB002	2E										
9F60CEB003	3E										
9F60CEB005	5E										
9F60CEB007	7E										
9F60CEB010	10E										
9F60CEB015	15E										
9F60CEB020	20E										
9F60CEB025	25E										

2.75kV Power Distribution fuses - 9F60 Series, E-Rated EJO-1

12" (305 mm) Clip Centers - Suitable for use indoors or outdoors



Catalog No	Amp Rating	No. of Barrels	Indicating	Diameter Inches (mm)	Length Inches (mm)	Max Voltage	Max IR RMS Sym	Fuse Support Indoor (EK-1)	Fuse Support Outdoor (EKO-1)	Fuse Disconnect Indoor (EK-3)	Fuse Disconnect Outdoor (EKO-3)
9F60DJB001	1E	1	Yes	2 (50.8)	14.18 (360)	2.75 kV	50kA	9F61AEG201	9F61CEF209	9F61AEG205	9F61CEF210
9F60DJB002	2E										
9F60DJB003	3E										
9F60DJB005	5E										
9F60DJB007	7E										
9F60DJB010	10E										
9F60DJB015	15E										
9F60DJB020	20E										
9F60DJB025	25E										
9F60FJB030	30E										
9F60FJB040	40E										
9F60FJB050	50E										
9F60FJB065	65E										
9F60FJB080	80E										
9F60FJB100	100E										
9F60FJL030	30E	1	No	3 (76.2)	15.88 (403)	2.75 kV	50kA	9F61AEB301	9F61CEF309	9F61AEB305	9F61CEF310
9F60FJL040	40E										
9F60FJL050	50E										
9F60FJL065	65E										
9F60FJL080	80E										
9F60FJL100	100E										
9F60HJB125	125E	2	Yes	3 (76.2)	15.88 (403)	2.75 kV	50kA	9F61AEB401	9F61CEF409	9F61AEB405	9F61CEF410
9F60HJB150	150E										
9F60HJB200	200E										



5.5kV FERRULE MOUNTED FUSES:

5.5kV Power Distribution fuses – 9F60 Series, E-Rated EJ-1

9" (229 mm) Clip Centers - Suitable for use indoors or in an enclosure only

Catalog No.	Amp Rating	No. of Barrels	Indicating	Diameter Inches (mm)	Length Inches (mm)	Max Voltage	Max IR RMS Sym	Fuse Support Indoor (EK-1)	Fuse Support Outdoor (EK0-1)	Fuse Disconnect Indoor (EK-3)	Fuse Disconnect Outdoor (EK0-3)
9F60CED905	0.5E	1	Yes	2 (50.8)	11.18 (284)	5.5 kV	63kA	9F61ACB201	N/A	9F61ACB205	N/A
9F60CED001	1E										
9F60CED002	2E										
9F60CED003-S	3E										
9F60CED005	5E										
9F60CED007	7E										
9F60CED010	10E										
9F60CED015	15E										
9F60CED020	20E										
9F60CED025	25E										
9F60CEN010	10E		No								
9F60CEN015	15E										
9F60CEN020	20E										
9F60CEN025	25E										



5.5kV E-Rated Amp-Trap CS-3 Series – UL Listed

12" (305 mm) Clip Centers - Suitable for use indoors or in an enclosure only



Catalog No.	Amp Rating	No. of Barrels	Indicating	Diameter Inches (mm)	Length Inches (mm)	Max Voltage	Max IR RMS Sym	Fuse Support Indoor (EK-1)	Fuse Support Outdoor (EK0-1)	Fuse Disconnect Indoor (EK-3)	Fuse Disconnect Outdoor (EK0-3)										
A055F1COR0-5E	5E	1	Yes	2 (50.8)	14.18 (360)	5.5kV	63kA	9F61AEG201	N/A	9F61AEG205	N/A										
A055F1COR0-7E	7E																				
A055F1COR0-10E	10E																				
A055F1COR0-15E	15E																				
A055F1COR0-20E	20E																				
A055F1COR0-25E	25E																				
A055F1COR0-30E	30E																				
A055F1COR0-40E	40E																				
A055F1COR0-50E	50E																				
A055F1COR0-65E	65E																				
A055F1DOR0-10E	10E	1	Yes	3 (76.2)	15.88 (403)	5.5kV	63kA	9F61AEB301	N/A	9F61AEB305	N/A										
A055F1DOR0-15E	15E																				
A055F1DOR0-20E	20E																				
A055F1DOR0-25E	25E																				
A055F1DOR0-30E	30E																				
A055F1DOR0-40E	40E																				
A055F1DOR0-50E	50E																				
A055F1DOR0-65E	65E																				
A055F1DOR0-80E	80E																				
A055F1DOR0-100E	100E																				
A055F1DOR0-125E	125E																				
A055F1DOR0-150E	150E																				
A055F1DOR0-175E	175E																				
A055F1DOR0-200E	200E																				
A055F2DOR0-250E	250E											2	Yes	3 (76.2)	15.88 (403)	5.5kV	63kA	-	N/A	-	N/A
A055F2DOR0-300E	300E																				
A055F2DOR0-350E	350E																				
A055F2DOR0-400E	400E																				
A055F2DOR0-450E	450E																				

TRANSFORMER PROTECTION

Amp-Trap® CS-3 Series and 9F60/9F62 Series

MEDIUM VOLTAGE
FUSES

5.5kV General Purpose fuses – 9F62 Series, EJO-1 – UL Listed

12" (305 mm) Clip Centers - Suitable for use indoors or outdoors



Catalog No.	Amp Rating	No. of Barrels	Indicating	Diameter Inches (mm)	Length Inches (mm)	Max Voltage	Max IR RMS Sym	Fuse Support Indoor (EK-1)	Fuse Support Outdoor (EK0-1)	Fuse Disconnect Indoor (EK-3)	Fuse Disconnect Outdoor (EK0-3)
9F62HCB025	25	1	Yes	2 (50.8)	14.18 (360)	5.5 kV	80kA	9F61AEG201	9F61CEF209	9F61AEG205	9F61CEF210
9F62HCB030	30										
9F62HCB040	40										
9F62HCB050	50										
9F62HCB065	65										
9F62DCB080	80	1	Yes	3 (76.2)	15.88 (403)	5.5 kV	80kA	9F61AEB301	9F61CEF309	9F61AEB305	9F61CEF310
9F62DCB100	100										
9F62DCB125	125										
9F62DCB150	150										
9F62DCB175	175										
9F62DCB200	200	2	Yes	3 (76.2)	15.88 (403)	5.5 kV	80kA	9F61AEB401	9F61CEF409	9F61AEB405	9F61CEF410
9F62FCB250	250										
9F62FCB300	300										
9F62FCB350	350										
9F62FCB400	400										
9F62FCB450	450										

5.5kV General Purpose fuses – 9F62 Series, EJO-1 – UL Listed

12" (305 mm) Clip Centers - Suitable for use indoors or outdoors. Non-indicating for Class 1, Division 2 locations.



Catalog No.	Amp Rating	No. of Barrels	Indicating	Diameter Inches (mm)	Length Inches (mm)	Max Voltage	Max IR RMS Sym.	Fuse Support Indoor (EK-1)	Fuse Support Outdoor (EK0-1)	Fuse Disconnect Indoor (EK-3)	Fuse Disconnect Outdoor (EK0-3)
9F62HCJ025	25	1	No	2 (50.8)		5.5 kV	80kA	9F61AEG201	9F61CEF209	9F61AEG205	9F61CEF210
9F62HCJ030	30										
9F62HCJ040	40										
9F62HCJ050	50										
9F62HCJ065	65										
9F62DCJ080	80	1	No	3 (76.2)		5.5 kV	80kA	9F61AEB301	9F61CEF309	9F61AEB305	9F61CEF310
9F62DCJ100	100										
9F62DCJ125	125										
9F62DCJ150	150										
9F62DCJ175	175										
9F62DCJ200	200	2	No	3 (76.2)		5.5 kV	80kA	9F61AEB401	9F61CEF409	9F61AEB405	9F61CEF410
9F62FCJ250	250										
9F62FCJ300	300										
9F62FCJ350	350										
9F62FCJ400	400										
9F62FCJ450	450										

5.5kV Power Distribution fuses – 9F60 Series, E-Rated EJO-1

12" (305 mm) Clip Centers - Suitable for use indoors or outdoors



Catalog No.	Amp Rating	No. of Barrels	Indicating	Diameter Inches (mm)	Length Inches (mm)	Max Voltage	Max IR RMS Sym	Fuse Support Indoor (EK-1)	Fuse Support Outdoor (EK0-1)	Fuse Disconnect Indoor (EK-3)	Fuse Disconnect Outdoor (EK0-3)
9F60JD0905	0.5E	1	Yes	2 (50.8)	14.18 (360)	5.5 kV	50kA	9F61AEG201	9F61CEF209	9F61AEG205	9F61CEF210
9F60JD001	1E										
9F60JD002	2E										
9F60JD003	3E										
9F60JD005	5E										
9F60JD007	7E										
9F60JD010	10E										
9F60JD015	15E										
9F60JD020	20E										
9F60JD025	25E										
9F60FJD030	30E	1	Yes	3 (76.2)	15.88 (403)	5.5 kV	50kA	9F61AEB301	9F61CEF309	9F61AEB305	9F61CEF310
9F60FJD040	40E										
9F60FJD050	50E										
9F60FJD065	65E										
9F60FJD080	80E										
9F60FJD100	100E	2	Yes	3 (76.2)	15.88 (403)	5.5 kV	50kA	9F61AEB401	9F61CEF409	9F61AEB405	9F61CEF410
9F60HJD125	125E										
9F60HJD150	150E										
9F60HJD200	200E										

8.25kV / 8.3kV FERRULE MOUNTED FUSES:

8.25kV E-Rated Amp-Trap CS-3 Series

12" (305 mm) Clip Centers - Suitable for use indoors or in an enclosure only

Catalog No.	Amp Rating	No. of Barrels	Indicating	Diameter Inches (mm)	Length Inches (mm)	Max Voltage	Max IR RMS Sym	Fuse Support Indoor [EK-1]	Fuse Support Outdoor [EK0-1]	Fuse Disconnect Indoor [EK-3]	Fuse Disconnect Outdoor [EK0-3]
A825X10E-1	10E	1	Yes	3 (76.2)	15.88 (403)	8.25kV	70kA	9F61AEG301	N/A	9F61AEG305	N/A
A825X15E-1	15E										
A825X20E-1	20E										
A825X25E-1	25E										
A825X30E-1	30E										
A825X40E-1	40E										
A825X50E-1	50E										
A825X65E-1	65E										
A825X80E-1	80E										
A825X100E-1	100E										
A825X125E-1	125E	2	Yes	3 (76.2)	15.88 (403)	8.25kV	70kA	-	N/A	-	N/A
A825X150E-1	150E										
A825X200E-1	200E										

8.3kV General Purpose fuses - 9F62 Series, EJO-1 - UL Listed

12" (305 mm) Clip Centers - Suitable for use indoors or outdoors



Catalog No.	Amp Rating	No. of Barrels	Indicating	Diameter Inches (mm)	Length Inches (mm)	Max Voltage	Max IR RMS Sym	Fuse Support Indoor [EK-1]	Fuse Support Outdoor [EK0-1]	Fuse Disconnect Indoor [EK-3]	Fuse Disconnect Outdoor [EK0-3]
9F62HCC020	20A	1	Yes	2 (50.8)	14.18 (360)	8.3 kV	50kA	9F61AEG201	9F61CEF209	9F61AEG205	9F61CEF210
9F62HCC025	25A										
9F62HCC030	30A										
9F62HCC040	40A										
9F62HCC050	50A										
9F62DCC065	65A	1	Yes	3 (76.2)	15.88 (403)	8.3 kV	50kA	9F61AEG301	9F61CEF309	9F61AEG305	9F61CEF310
9F62DCC080	80A										
9F62DCC100	100A										
9F62DCC125	125A										
9F62DCC150	150A										
9F62FCC175	175A	2	Yes	3 (76.2)	15.88 (403)	8.3 kV	50kA	9F61AEG401	9F61CEF409	9F61AEG405	9F61CEF410
9F62FCC200	200A										
9F62FCC250	250A										

8.25kV Power Distribution fuses - 9F60 Series, E-Rated EJO-1

12" (305 mm) Clip Centers - Suitable for use indoors or outdoors



Catalog No.	Amp Rating	No. of Barrels	Indicating	Diameter Inches (mm)	Length Inches (mm)	Max Voltage	Max IR RMS Sym	Fuse Support Indoor [EK-1]	Fuse Support Outdoor [EK0-1]	Fuse Disconnect Indoor [EK-3]	Fuse Disconnect Outdoor [EK0-3]										
9F60DJE905	0.5E	1	Yes	2 (50.8)	14.18 (360)	8.25 kV	50kA	9F61AEG201	9F61CEF209	9F61AEG205	9F61CEF210										
9F60DJE001	1E																				
9F60DJE002	2E																				
9F60DJE003	3E																				
9F60DJE005	5E																				
9F60DJE007	7E																				
9F60DJE010	10E																				
9F60DJE015	15E																				
9F60FJE020	20E											1	Yes	3 (76.2)	15.88 (403)	8.25 kV	50kA	9F61AEG301	9F61CEF309	9F61AEG305	9F61CEF310
9F60FJE025	25E																				
9F60FJE030	30E																				
9F60FJE040	40E																				
9F60FJE050	50E																				
9F60FJE065	65E																				
9F60FJE080	80E																				
9F60FJE100	100E																				
9F60HJE125	125E	2	Yes	3 (76.2)	15.88 (403)	8.25 kV	50kA	9F61AEG401	9F61CEF409	9F61AEG405	9F61CEF410										
9F60HJE150	150E																				
9F60HJE200	200E																				

15kV / 15.5kV FERRULE MOUNTED FUSES:

15.5kV Power Distribution fuses – 9F60 Series, E-Rated EJ-1

12" (305 mm) Clip Centers - Suitable for use indoors or in an enclosure only

Catalog No.	Amp Rating	No. of Barrels	Indicating	Diameter Inches (mm)	Length Inches (mm)	Max Voltage	Max IR RMS Sym	Fuse Support Indoor (EK-1)	Fuse Support Outdoor (EK0-1)	Fuse Disconnect Indoor (EK-3)	Fuse Disconnect Outdoor (EK0-3)
9F60CJH002	2E	1	Yes	2 (50.8)	14.18 (360)	15.5 kV	82kA	9F61AEG201	N/A	9F61AEG205	N/A
9F60CJH003	3E										
9F60CJH005	5E										
9F60CJH007	7E										
9F60CJH010	10E										

15.5kV Power Distribution fuses – 9F60 Series, E-Rated EJO-1

15" (381 mm) Clip Centers - Suitable for use indoors or outdoors



Catalog No.	Amp Rating	No. of Barrels	Indicating	Diameter Inches (mm)	Length Inches (mm)	Max Voltage	Max IR RMS Sym	Fuse Support Indoor (EK-1)	Fuse Support Outdoor (EK0-1)	Fuse Disconnect Indoor (EK-3)	Fuse Disconnect Outdoor (EK0-3)
9F60DMH905	0.5E	1	Yes	2 (50.8)	17.2 (437)	15.5 kV	120kA	9F61AGG201 (13.8kV nominal - 95kV BIL) 9F61AGJ201 (14.4kV nominal - 110kV BIL)	9F61CGL209	9F61AGG205 (13.8kV nominal - 95kV BIL) 9F61AGJ205 (14.4kV nominal - 110kV BIL)	9F61CGL210
9F60DMH001	1E										
9F60DMH002	2E										
9F60DMH003	3E										
9F60DMH005	5E										
9F60DMH007	7E										
9F60DMH010	10E										
9F60FMH015	15E	1	Yes	3 (76.2)	18.88 (480)	15.5 kV	50kA	9F61AGG301 (13.8kV nominal - 95kV BIL) 9F61AGJ301 (14.4kV nominal - 110kV BIL)	9F61CGL309	9F61AGG305 (13.8kV nominal - 95kV BIL) 9F61AGJ305 (14.4kV nominal - 110kV BIL)	9F61CGL310
9F60FMH020	20E										
9F60FMH025	25E										
9F60FMH030	30E										
9F60FMH040	40E										
9F60FMH050	50E										
9F60HMH065	65E	2	Yes	3 (76.2)	18.88 (480)	15.5 kV	50kA	9F61AGG401 (13.8kV nominal - 95kV BIL) 9F61AGJ401 (14.4kV nominal - 110kV BIL)	9F61CGL409	9F61AGG405 (13.8kV nominal - 95kV BIL) 9F61AGJ405 (14.4kV nominal - 110kV BIL)	9F61CGL410
9F60HMH080	80E										
9F60HMH100	100E										

15.5kV General Purpose fuses – 9F62 Series, EJO-1 – UL Listed
15" (381 mm) Clip Centers - Suitable for use indoors or outdoors



Catalog No.	Amp Rating	No. of Barrels	Indicating	Diameter Inches (mm)	Length Inches (mm)	Max Voltage	Max IR RMS Sym	Fuse Support Indoor (EK-1)	Fuse Support Outdoor (EK0-1)	Fuse Disconnect Indoor (EK-3)	Fuse Disconnect Outdoor (EK0-3)
9F62DDD050	50A	1	Yes	3 (76.2)	18.88 (480)	15.5 kV	50kA	9F61AGG301 (13.8kV nominal - 95kV BIL) 9F61AGJ301 (14.4kV nominal - 110kV BIL)	9F61CGL309	9F61AGG305 (13.8kV nominal - 95kV BIL) 9F61AGJ305 (14.4kV nominal - 110kV BIL)	9F61CGL310
9F62DDD065	65A										
9F62DDD080	80A										
9F62DDD100	100A										
9F62FDD125	125A	2	Yes	3 (76.2)	18.88 (480)	15.5 kV	50kA	9F61AGG401 (13.8kV nominal - 95kV BIL) 9F61AGJ401 (14.4kV nominal - 110kV BIL)	9F61CGL409	9F61AGG405 (13.8kV nominal - 95kV BIL) 9F61AGJ405 (14.4kV nominal - 110kV BIL)	9F61CGL410
9F62FDD150	150A										
9F62FDD175	175A										
9F62FDD200	200A										

15.5kV E-Rated Amp-Trap CS-3 series – UL Listed
15" (381 mm) Clip Centers - Suitable for use indoors or in an enclosure only



Catalog No.	Amp Rating	No. of Barrels	Indicating	Diameter Inches (mm)	Length Inches (mm)	Max Voltage	Max IR RMS Sym	Fuse Support Indoor (EK-1)	Fuse Support Outdoor (EK0-1)	Fuse Disconnect Indoor (EK-3)	Fuse Disconnect Outdoor (EK0-3)
A155F1CORO-5E	5E	1	Yes	2 (50.8)	1703 (433)	15.5kV	50kA	9F61AGG201 (13.8kV nominal - 95kV BIL) 9F61AGJ201 (14.4kV nominal - 110kV BIL)	N/A	9F61AGG205 (13.8kV nominal - 95kV BIL) 9F61AGJ205 (14.4kV nominal - 110kV BIL)	N/A
A155F1CORO-7E	7E										
A155F1CORO-10E	10E										
A155F1CORO-15E	15E										
A155F1CORO-20E	20E										
A155F1CORO-25E	25E										
A155F1CORO-30E	30E	1	Yes	3 (76.2)	18.87 (479)	15.5kV	50kA	9F61AGG301 (13.8kV nominal - 95kV BIL) 9F61AGJ301 (14.4kV nominal - 110kV BIL)	N/A	9F61AGG305 (13.8kV nominal - 95kV BIL) 9F61AGJ305 (14.4kV nominal - 110kV BIL)	N/A
A155F1DORO-10E	10E										
A155F1DORO-15E	15E										
A155F1DORO-20E	20E										
A155F1DORO-25E	25E										
A155F1DORO-30E	30E										
A155F1DORO-40E	40E	2	Yes	3 (76.2)	18.87 (479)	15.5kV	50kA	-	N/A	-	N/A
A155F1DORO-50E	50E										
A155F2DORO-65E	65E										
A155F2DORO-80E	80E										
A155F2DORO-100E	100E										

15.5kV E-Rated Amp-Trap CS-3 series – UL Listed
18" (457 mm) Clip Centers - Suitable for use indoors or in an enclosure only



Catalog No.	Amp Rating	No. of Barrels	Indicating	Diameter Inches (mm)	Length Inches (mm)	Max Voltage	Max IR RMS Sym	Fuse Support Indoor (EK-1)	Fuse Support Outdoor (EK0-1)	Fuse Disconnect Indoor (EK-3)	Fuse Disconnect Outdoor (EK0-3)
A155F1DORO-65E	65E	1	Yes	3 (76.2)	21.75 (552)	15.5kV	50kA	-	N/A	-	N/A
A155F1DORO-80E	80E										
A155F1DORO-100E	100E										
A155F2DORO-125E	125E	2	Yes	3 (76.2)	21.75 (552)	15.5kV	50kA	-	N/A	-	N/A
A155F2DORO-150E	150E										
A155F2DORO-175E	175E										
A155F2DORO-200E	200E										



25.8kV FERRULE MOUNTED FUSES:

25.8kV Power Distribution fuses – 9F60 Series, E-Rated EJ-1

15" (381 mm) Clip Centers - Suitable for use indoors or in an enclosure only

Catalog No.	Amp Rating	No. of Barrels	Indicating	Diameter Inches (mm)	Length Inches (mm)	Max Voltage	Max IR RMS Sym	Fuse Support Indoor (EK-1)	Fuse Support Outdoor (EK0-1)	Fuse Disconnect Indoor (EK-3)	Fuse Disconnect Outdoor (EK0-3)
9F60CMJ905	0.5E	1	Yes	2 (50.8)	17.20 (437)	25.8 kV	35kA*	-	N/A	-	N/A
9F60CMJ001	1E										
9F60CMJ002	2E										

25.8kV Power Distribution fuses – 9F60 Series, E-Rated EJO-1

21" (533 mm) Clip Centers - Suitable for use indoors or outdoors



Catalog No.	Amp Rating	No. of Barrels	Indicating	Diameter Inches (mm)	Length Inches (mm)	Max Voltage	Max IR RMS Sym	Fuse Support Indoor (EK-1)	Fuse Support Outdoor (EK0-1)	Fuse Disconnect Indoor (EK-3)	Fuse Disconnect Outdoor (EK0-3)
9F60DNJ905	0.5E	1	Yes	2 (50.8)	23.18 (589)	25.8 kV	35kA*	9F61AHM201	9F61CHM209	9F61AHM205	9F61CHM210
9F60DNJ001	1E										
9F60DNJ002	2E										
9F60DNJ003	3E										
9F60DNJ005	5E										
9F60DNJ007	7E										
9F60DNJ010	10E										
9F60FNJ015	15E	1	Yes	3 (76.2)	24.81 (630)	25.8 kV	25kA	9F61AHM301	9F61CHM309	9F61AHM305	9F61CHM310
9F60FNJ020	20E										
9F60FNJ025	25E										
9F60FNJ030	30E										
9F60FNJ040	40E										
9F60FNJ050	50E										
9F60HNJ065	65E										
9F60HNJ080	80E	2	Yes	3 (76.2)	24.81 (630)	25.8 kV	25kA	9F61AHM401	9F61CHM409	9F61AHM405	9F61CHM410
9F60HNJ100	100E										

38kV FERRULE MOUNTED FUSES:

38kV Power Distribution fuses – 9F60 Series, E-Rated EJO-1

27" (686 mm) Clip Centers - Suitable for use indoors or outdoors



Catalog No.	Amp Rating	No. of Barrels	Indicating	Diameter Inches (mm)	Length Inches (mm)	Max Voltage	Max IR RMS Sym	Fuse Support Indoor (EK-1)	Fuse Support Outdoor (EK0-1)	Fuse Disconnect Indoor (EK-3)	Fuse Disconnect Outdoor (EK0-3)
9F60FPK001	1E	1	Yes	3 (76.2)	30.81 (783)	38 kV	26kA*	-	9F61CJN309	-	9F61CJN310
9F60FPK002	2E										
9F60FPK003	3E										
9F60FPK005	5E										
9F60FPK007	7E										
9F60FPK010	10E										
9F60FPK015	15E	1	Yes	3 (76.2)	30.81 (783)	38 kV	13kA	-	9F61CJN309	-	9F61CJN310
9F60FPK020	20E										
9F60FPK025	25E										
9F60FPK030	30E										
9F60FPK040	40E										
9F60HPK050	50E										
9F60HPK065	65E	2	Yes	3 (76.2)	30.81 (783)	38 kV	13kA	-	9F61CJN409	-	9F61CJN410
9F60HPK080	80E										
9F60FPT001	1E	1	No	3 (76.2)	30.81 (783)	38 kV	26kA*	-	9F61CJN309	-	9F61CJN310
9F60FPT002	2E										
9F60FPT003	3E										
9F60FPT005	5E										
9F60FPT007	7E										
9F60FPT010	10E										
9F60FPT015	15E	1	No	3 (76.2)	30.81 (783)	38 kV	13kA	-	9F61CJN309	-	9F61CJN310
9F60FPT020	20E										
9F60FPT025	25E										
9F60FPT030	30E										
9F60FPT040	40E										
9F60HPT050	50E										
9F60HPT065	65E	2	No	3 (76.2)	30.81 (783)	38 kV	13kA	-	9F61CJN409	-	9F61CJN410
9F60HPT080	80E										

* These fuses were designed and originally tested at a higher maximum interrupting rating value. Consult factory for further information.



Transformer Protection

Amp-Trap® and 9F62 Bolt-In Series

MEDIUM VOLTAGE FUSES

5.0kV, 5.5kV, 7.2kV, 8.25kV, AND 15.5kV
BOLT-IN FUSES



Mersen fuses for the protection of transformers and distribution lines deliver overload and short circuit protection. These current-limiting fuses will melt at current that can be as low as 1.7 times the fuse current ratings up to its maximum interrupting rating. These fuses are designed to withstand the transformer magnetizing inrush current. They are single, double, triple or quadruple barrels 3 inch diameter (size D) with end mounts designed for bolting directly to equipment bus or terminal pads.

FEATURES/BENEFITS:

- UL listed for compatibility with UL listed equipment.
- Bolt-In mounting for direct connection to bus or terminals.
- Current-limiting for superior equipment protection.
- Non-venting for silent operation.
- Metal embossed catalog number and manufacturing date for lasting identification.
- Outdoor usage for the 9F62.
- Blown-fuse indicator to give positive identification of open fuse.
 - Amp trap: 1 lb tripped force - 0.44 Inch
 - 9F62: 0.125 lb tripped force - 0.20 Inch

HIGHLIGHTS:

- E-Rated
- UL listed
- Outdoor use



APPLICATIONS:

- Protection for 5.5kV to 15.5kV transformers or distribution systems.

Ratings:

Amp-Trap Bolt-in Series

A050B:

- **Volts:** 5.0kV AC
- **Amps:** 1200E
- **IR:** 59kA Sym

A055B:

- **Volts:** 5.5kV AC
- **Amps:** 10 to 900E
- **IR:** 50kA-63kA

A072B:

- **Volts:** 7.2kVAC
- **Amps:** 250 to 400E
- **IR:** 65kA Sym

A083B:

- **Volts:** 8.25kVAC
- **Amps:** 10 to 200E
- **IR:** 70kA Sym

A155B:

- **Volts:** 15.5kVAC
- **Amps:** 10 to 300E
- **IR:** 50kA Sym

9F62 Series Type EJO-1

9F62

- **Volts:** 5.5kVAC, 15.5VAC
- **Amps:** 300 to 900A
- **IR:** 50kA Sym

APPROVALS:



- Some UL Listed to standard File E143362

DEFINITIONS:

General Purpose Current-Limiting Fuses (Per IEEE Std C37.41-2016):

A general purpose current-limiting fuse is one that is capable of interrupting all currents, from its rated maximum interrupting current down to a low value equal to the current that causes melting of the fuse elements in one hour or more, under specified conditions.

E-Rating: E-Rated fuses operate as follows (Per IEEE C37.42-2016):

- 100E or less - must melt in 300 seconds (5 mins.) at 200 to 240% of E (ampere) rating.
- Over 100E - must melt in 600 seconds (10 mins.) at 220 to 264% of E (ampere) rating.
- Example: A 100E fuse must melt in 300 seconds with an applied current of 200 to 240 amperes.

5.0kV / 5.5kV BOLT-IN FUSES:

5.5kV E-Rated Amp-Trap Bolt-In Series - UL Listed

Suitable for use indoors or in an enclosure only



Catalog Number	Amp Rating	No. of Barrels	Indicating	Max Voltage	Max IR RMS Sym	Figure
A055B1DARO-10E	10E	1	Yes	5.5kV	63kA	A
A055B1DARO-15E	15E					
A055B1DARO-20E	20E					
A055B1DARO-25E	25E					
A055B1DARO-30E	30E					
A055B1DARO-40E	40E					
A055B1DARO-50E	50E					
A055B1DARO-65E	65E					
A055B1DARO-80E	80E					
A055B1DARO-100E	100E					
A055B1DARO-125E	125E					
A055B1DARO-150E	150E					
A055B1DARO-175E	175E					
A055B1DARO-200E	200E					

Figure A

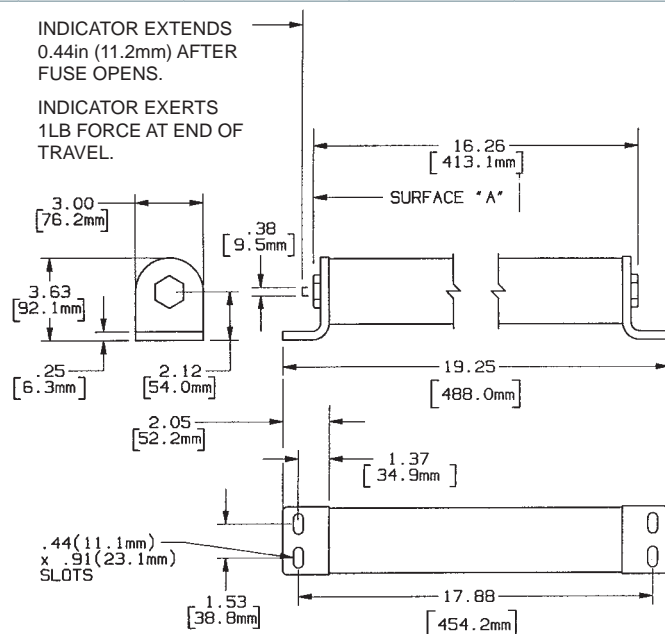



5.0kV / 5.5kV BOLT-IN FUSES:

5.5kV E-Rated Amp-Trap Bolt-In Series - UL Listed

Suitable for use indoors or in an enclosure only

Catalog Number	Amp Rating	No. of Barrels	Indicating	Max Voltage	Max IR RMS Sym	Figure
A055B2DARO-250E	250E	2	Yes	5.5kV	63kA	B
A055B2DARO-300E	300E					
A055B2DARO-350E	350E					
A055B2DARO-400E	400E					
A055B2DARO-450E	450E					
A055B2DORO-450E	450E	2	Yes	5.5kV	63kA	C
A055B2DORO-500E	500E					
A055B2DORO-600E	600E					
A055B3DORO-750E	750E	3	Yes	5.5kV	63kA	D
A055B3DORO-900E	900E					

Figure B

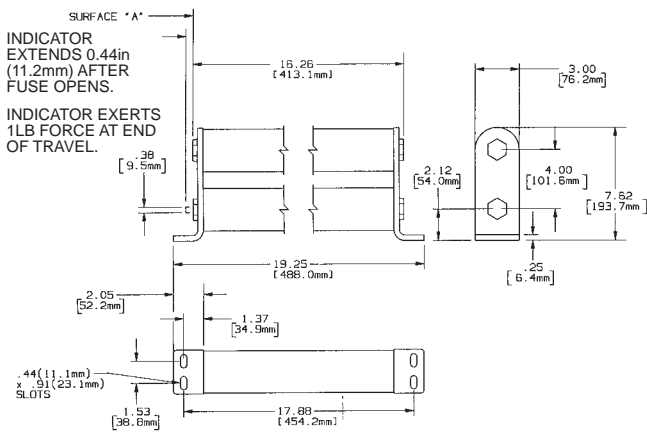

Figure C

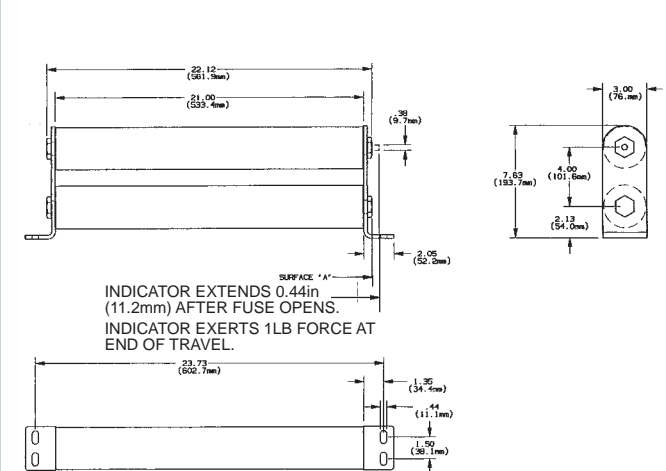
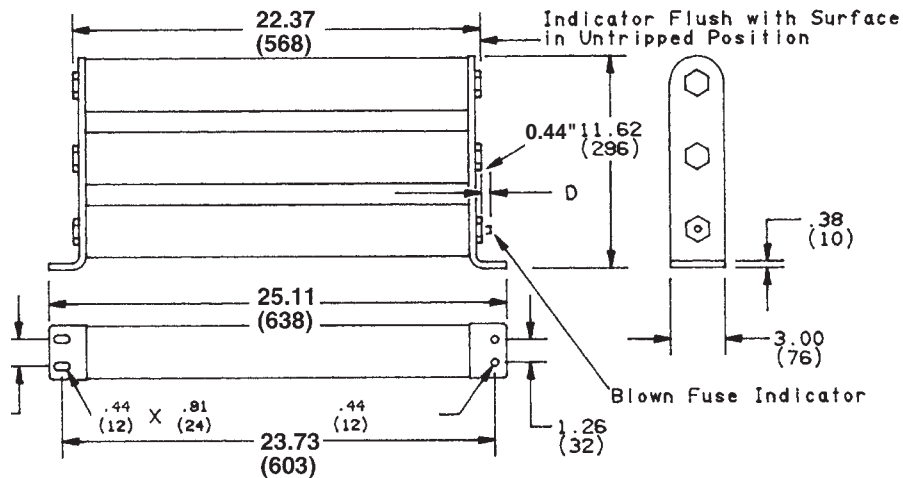

Figure D



MV

5.0kV / 5.5kV BOLT-IN FUSES:

5.0kV E-Rated Amp-Trap Bolt-In Series

Suitable for use indoors or in an enclosure only

Catalog No.	Amp Rating	No. of Barrels	Indicating	Max Voltage	Max IR RMS Sym	Figure
A050B4D0R0-1200E	1200E	4	Yes	5.0kV	59kA	E

Figure E

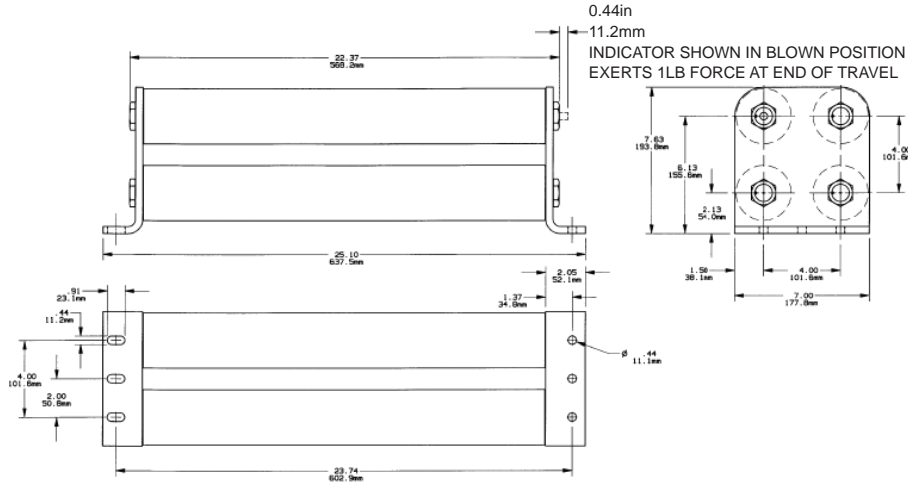

5.5kV General Purpose fuses - 9F62 Series, EJO-1 - UL Listed

Suitable for use indoors or outdoors



Catalog No.	Amp Rating	No. of Barrels	Indicating	Max Voltage	Max IR RMS Sym	Figure	Fuse Support Indoor (EK-1)	Fuse Support Outdoor (EK0-1)
9F62KCB500	500A	4	Yes	5.5 kV	50kA	F	9F61AKB001	9F61CKF009
9F62KCB600	600A							
9F62KCB700	700A							
9F62KCB800	800A							
9F62KCB900	900A							

Figure F

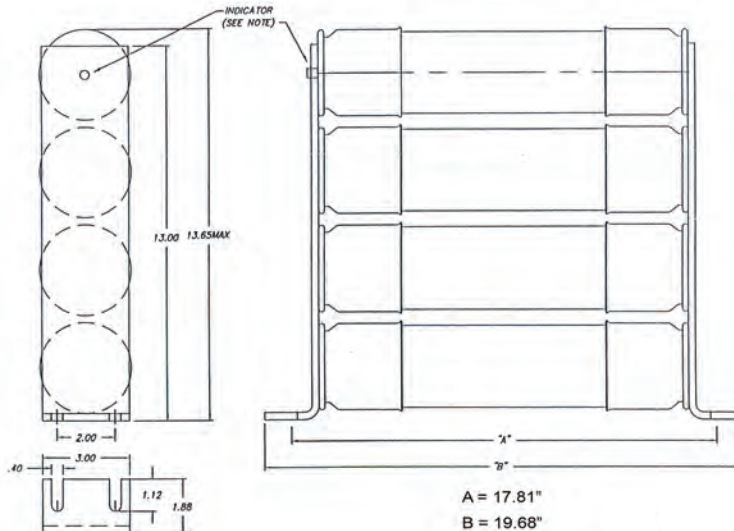



7.2kV / 8.25kV BOLT-IN FUSES:

7.2kV E-Rated Amp-Trap Bolt-In Series

Suitable for use indoors or in an enclosure only

Catalog No.	Amp Rating	No. of Barrels	Indicating	Max Voltage	Max IR RMS Sym	Figure
A072B2D0R0-250E	250E	2	Yes	7.9kV	65kA	G
A072B2D0R0-300E	300E					
A072B2D0R0-350E	350E					
A072B2D0R0-400E	400E					

Figure G

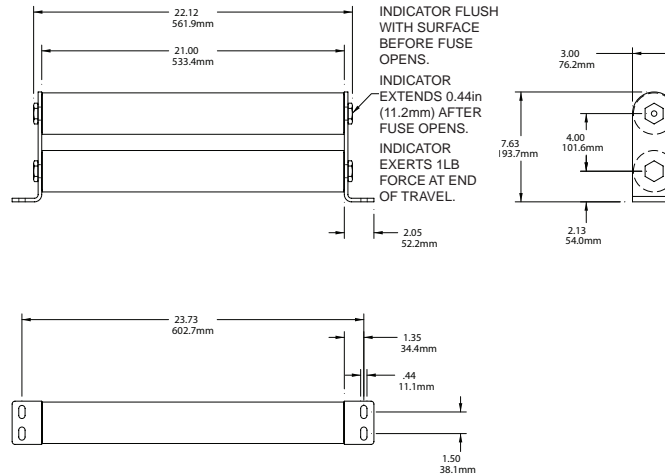

8.25kV E-Rated Amp-Trap Bolt-In Series

Suitable for use indoors or in an enclosure only

Catalog No.	Amp Rating	No. of Barrels	Indicating	Max Voltage	Max IR RMS Sym	Figure
A083B1DAR0	10-100	1	Yes	8.25kV	70kA	H
A083B2DAR0-125E	125E	2				
A083B2DAR0-150E	150E					
A083B2DAR0-175E	175E					
A083B2DAR0-200E	200E					

Figure H

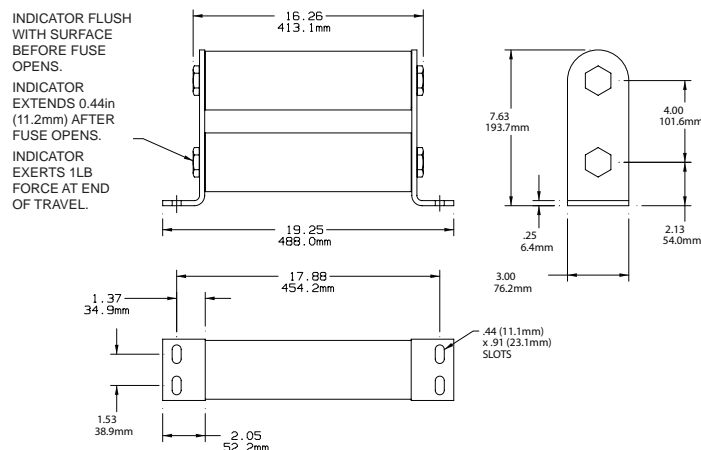



15.5kV BOLT-IN FUSES:

15.5kV E-Rated Amp-Trap Bolt-In Series

Suitable for use indoors or in an enclosure only

Catalog No.	Amp Rating	No. of Barrels	Indicating	Max Voltage	Max IR RMS Sym	Figure
A155B1D0R0-10E	10E	1	Yes	15.5kV	50kA	J
A155B1D0R0-15E	15E	1	Yes	15.5kV	50kA	J
A155B1D0R0-20E	20E	1	Yes	15.5kV	50kA	J
A155B1D0R0-25E	25E	1	Yes	15.5kV	50kA	J
A155B1D0R0-30E	30E	1	Yes	15.5kV	50kA	J
A155B1D0R0-40E	40E	1	Yes	15.5kV	50kA	J
A155B1D0R0-50E	50E	1	Yes	15.5kV	50kA	J
A155B1D0R0-65E	65E	1	Yes	15.5kV	50kA	K
A155B1D0R0-80E	80E	1	Yes	15.5kV	50kA	K
A155B1D0R0-100E	100E	1	Yes	15.5kV	50kA	K
A155B2D0R0-125E	125E	2	Yes	15.5kV	50kA	L
A155B2D0R0-150E	150E	2	Yes	15.5kV	50kA	L
A155B2D0R0-200E	200E	2	Yes	15.5kV	50kA	L
A155B3D0R0-250E	250E	3	Yes	15.5kV	50kA	M
A155B3D0R0-300E	300E	3	Yes	15.5kV	50kA	M



Figure J

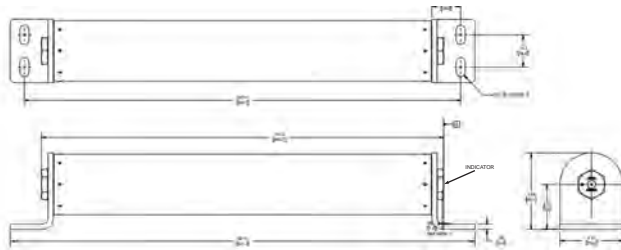

Figure K

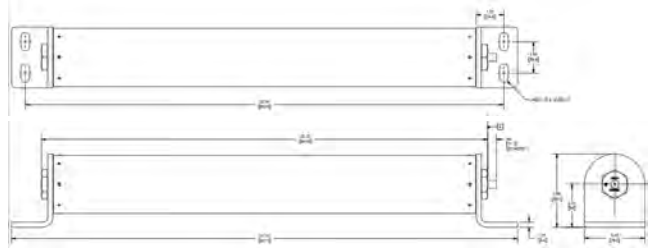

Figure L

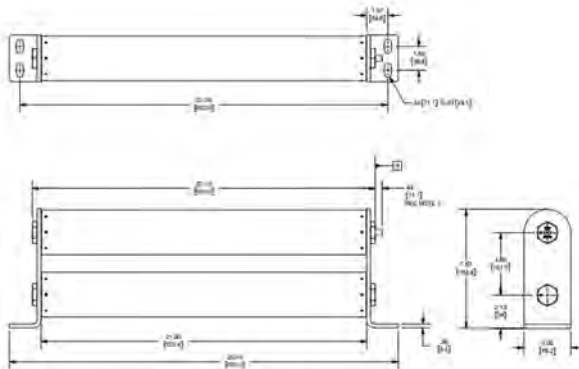
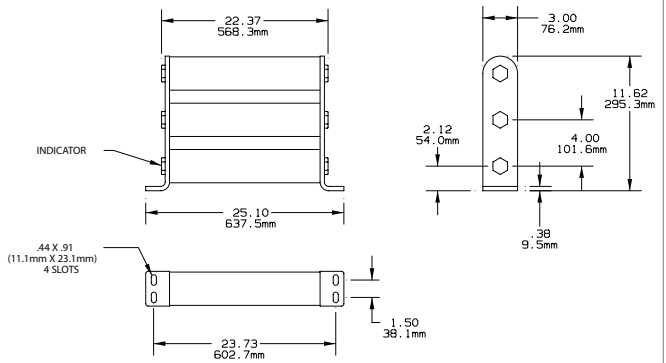

Figure M



15.5kV BOLT-IN FUSES:

15.5kV General Purpose fuses – 9F60 Series, EJO-1

Suitable for use indoors or outdoors



Catalog No.	Amp Rating	No. of Barrels	Indicating	Diameter Inches (mm)	Length Inches (mm)	Max Voltage	Max IR RMS Sym	Fig.	Fuse Support Indoor (EK-1)	Fuse Support Outdoor (EK0-1)	Fuse Disconnect Indoor (EK-3)	Fuse Disconnect Outdoor (EK0-3)
9F60XMH125	125A	4	Yes	3(76.2)	22.65" (575.3)	15.5 kV	50 kA	N	9F61GHL001	9FG1CHL009	N/A	N/A

15.5kV General Purpose fuses – 9F62 Series, EJO-1 – UL Listed

Suitable for use indoors or outdoors



Catalog No.	Amp Rating	No. of Barrels	Indicating	Max Voltage	Max IR RMS Sym	Figure	Fuse Support Indoor (EK-1)	Fuse Support Outdoor (EK0-1)
9F62KED300	300A	4	Yes	15.5 kV	50kA	N	9F61AHG001	9F61CHL009

Figure N

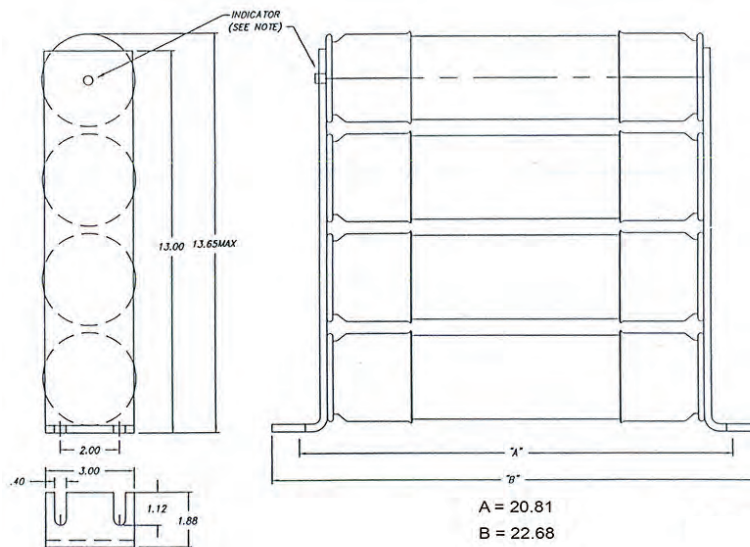

Transformer Protection

Amp-Trap® CL-14 Series

MEDIUM VOLTAGE FUSES

5.5kV, 8.25kV, AND 15.5kV
CLIP-LOCK MOUNTED FUSES



Mersen Amp-Trap fuses for the protection of transformers and distribution lines deliver overload and short circuit protection. These general purpose current-limiting fuses will melt at current that can be as low as 1.7 times the fuse current ratings up to its maximum interrupting rating. These fuses are designed to withstand the transformer magnetizing inrush current. They are single, double or triple barrels 3 inch diameter (size D) and mount in unique cam-locking clips for superior connections as well as easy installation and replacement.

FEATURES/BENEFITS:

- UL listed for compatibility with UL listed equipment.
- Clip-lock mounting for reliable high integrity connection into circuit.
- Current-limiting for superior equipment protection.
- Non-venting for silent operation.
- Metal embossed catalog number and manufacturing date for lasting identification.
- Blown-fuse indicator to give positive identification of open fuse.
 - 2 lb tripped force - 0.50 Inch

HIGHLIGHTS:

- E-Rated
- UL listed

APPLICATIONS:

- Protection for 5.5kV to 15.5kV transformers or distribution systems.

Ratings:

Amp-Trap CL-14 Series

(Indoor or outdoors in a weatherproof enclosure)

A055C

- **Volts:** 5.5kV AC
- **Amps:** 10 to 600E
- **IR:** 63kA Sym

A083C:

- **Volts:** 8.25kV AC
- **Amps:** 60 to 200E
- **IR:** 70kA Sym

A155C

- **Volts:** 15.5kV AC
- **Amps:** 10 to 300E
- **IR:** 50kA Sym

APPROVALS:

- Some UL Listed to standard File E143362



See Fuse Blocks and Holders section for CL-14 Clip-Lock Clips

5.5kV / 8.25kV CLIP-LOCK MOUNTED FUSES:

5.5kV E-Rated Amp-Trap CL-14 Series

15.25" (388mm) Clip Centers (dimension E). Suitable for use indoors or in an enclosure only



Catalog No.	Amp Rating	No. of Barrels	Indicating	Max Voltage	Max IR RMS Sym	Figure	Dimensions Inches (mm)			
							A	B	C	E
A055C1D0R0-10E	10E	1	Yes	5.5kV	63kA	A	16.81 (427)	16.12 (410)	0.5 (13) Tripped Force 2 lbs.	15.25 (388)
A055C1D0R0-15E	15E									
A055C1D0R0-20E	20E									
A055C1D0R0-25E	25E									
A055C1D0R0-30E	30E									
A055C1D0R0-40E	40E									
A055C1D0R0-50E	50E									
A055C1D0R0-65E	65E									
A055C1D0R0-80E	80E									
A055C1D0R0-100E	100E									
A055C1D0R0-125E	125E									
A055C1D0R0-150E	150E									

5.5kV E-Rated Amp-Trap CL-14 Series

21.25" (540mm) Clip Centers (dimension E). Suitable for use indoors or in an enclosure only



Catalog No.	Amp Rating	No. of Barrels	Indicating	Max Voltage	Max IR RMS Sym	Figure	Dimensions Inches (mm)			
							A	B	C	E
A055C1D0R0-200E	200E	1	Yes	5.5kV	63kA	A	22.81 (580)	22.12 (562)	0.5 (13) Tripped Force 2 lbs.	21.25 (540)
A055C1D0R0-250E	250E									
A055C1D0R0-300E	300E									
A055C1D0R0-400E	400E									
A055C2D0R0-450E	450E	2	Yes	5.5kV	63kA	B	22.81 (580)	22.12 (562)	0.5 (13) Tripped Force 2 lbs.	21.25 (540)
A055C2D0R0-500E	500E									
A055C2D0R0-600E	600E									

Figure B

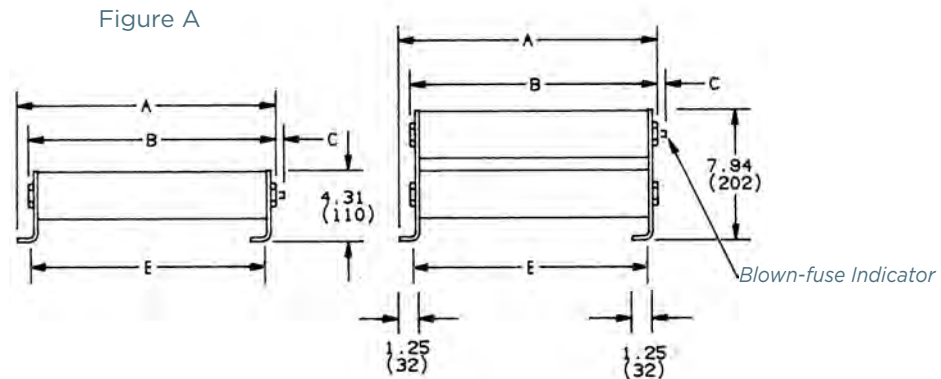

8.25kV E-Rated Amp-Trap CL-14 Series

15.70" (399mm) and 15.39 (391mm) Clip Centers (dimension E). Suitable for use indoors or in an enclosure only

Catalog No.	Amp Rating	No. of Barrels	Indicating	Max Voltage	Max IR RMS Sym	Figure	Dimensions Inches (mm)			
							A	B	C	E
A083C1D0R0-60E	60E	1	Yes	8.25kV	70kA	A	16.95 (431)	16.26 (413)	0.5 (13) Tripped Force 2 lbs.	15.39 (391)
A083C2D0R0-200E	200E	2	Yes	8.25kV	70kA	B	16.95 (431)	16.26 (413)	0.5 (13) Tripped Force 2 lbs.	15.39 (391)

Figure B

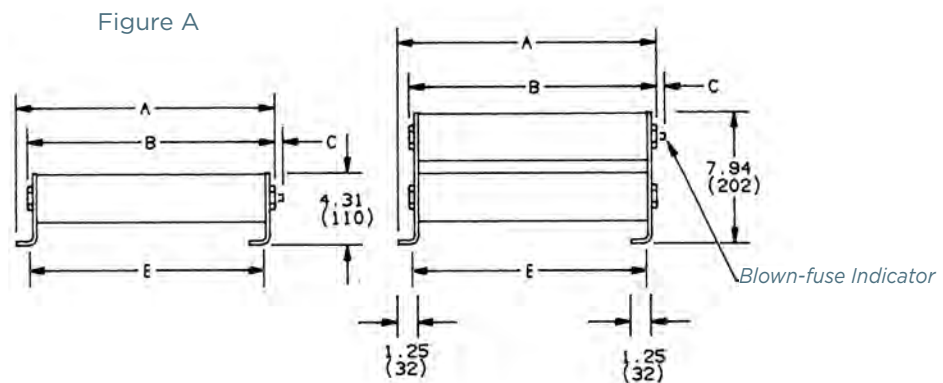

15.5kV CLIP-LOCK MOUNTED FUSES:

15.5kV E-Rated Amp-Trap CL-14 Series

18.25" (464mm) Clip Centers (dimension E). Suitable for use indoors or in an enclosure only



Catalog No.	Amp Rating	No. of Barrels	Indicating	Max Voltage	Max IR RMS Sym	Figure	Dimensions Inches (mm)			
							A	B	C	E
A155C1D0R0-10E	10E	1	Yes	15.5kV	50kA	A	19.81 (504)	19.12 (486)	0.5 (13) Tripped Force 2 lbs.	18.25 (464)
A155C1D0R0-15E	15E									
A155C1D0R0-20E	20E									
A155C1D0R0-25E	25E									
A155C1D0R0-30E	30E									
A155C1D0R0-40E	40E									
A155C1D0R0-50E	50E									

15.5kV E-Rated Amp-Trap CL-14 Series

21.25" (540mm) Clip Centers (dimension E). Suitable for use indoors or in an enclosure only



Catalog No.	Amp Rating	No. of Barrels	Indicating	Max Voltage	Max IR RMS Sym	Figure	Dimensions Inches (mm)			
							A	B	C	E
A155C1D0R0-65E	65E	1	Yes	15.5kV	50kA	A	22.81 (580)	22.12 (562)	0.5 (13) Tripped Force 2 lbs.	21.25 (540)
A155C1D0R0-80E	80E									
A155C1D0R0-100E	100E									
A155C2D0R0-125E	125E	2	Yes	15.5kV	50kA	B	22.81 (580)	22.12 (562)	0.5 (13) Tripped Force 2 lbs.	21.25 (540)
A155C2D0R0-150E	150E									
A155C2D0R0-200E	200E	3	Yes	15.5kV	50kA	C	22.81 (580)	22.12 (562)	0.5 (13) Tripped Force 2 lbs.	21.25 (540)
A155C3D0R0-150E	150E									
A155C3D0R0-200E	200E									
A155C3D0R0-250E	250E									
A155C3D0R0-300E	300E									

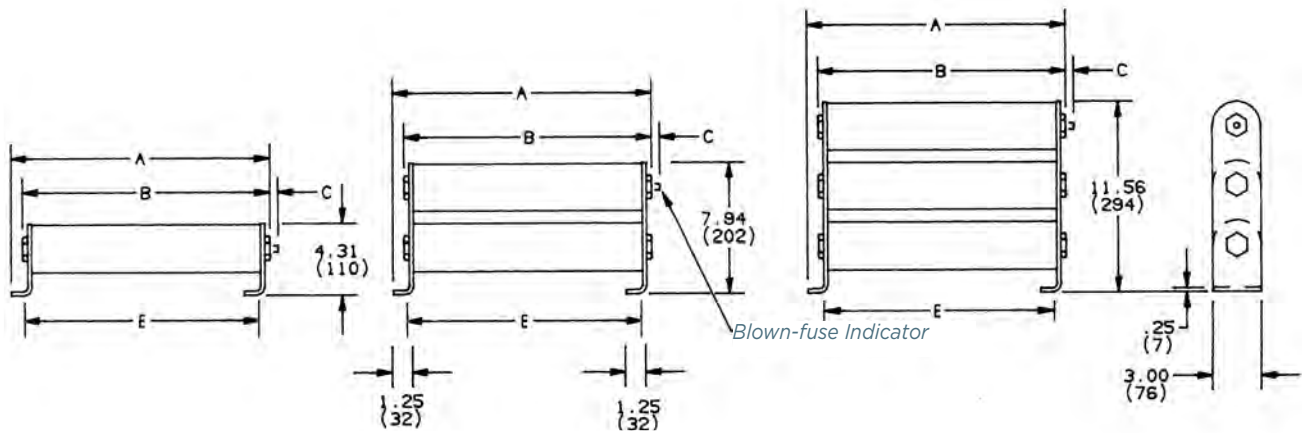

Figure A

Figure B

Figure C

M
V

Motor Protection

Amp-Trap® and 9F60 Series

MEDIUM VOLTAGE FUSES

2.4kV, 2.54kV, 4.8kV, 5.08kV AND 7.2kV
FERRULE MOUNTED FUSES



Mersen R-Rated fuses are current-limiting, high interrupting rating fuses intended for the short circuit protection of medium voltage motors and motor controllers. R-Rated fuses are back-up fuses that have a minimum interrupting rating, and must be coordinated with overload relays in combination motor starters. These fuses come with a 3 (size D) or 4 (size E) inch diameter barrels with ferrules and are mounted in spring reinforced clips. Used in and required for replacement in motor controllers by many major manufacturers.

FEATURES/BENEFITS:

- The Amp-Trap and 9F60 R-Rated fuses are UL Recognized.
- Ferrule mounting for standard clips and interchangeability with other brands of fuses.
- Current-limiting for superior equipment protection.
- Metal embossed catalog number and manufacturing date for lasting identification.
- Blown-fuse indicator to give positive identification of open fuse.
 - Amp trap: 3" Barrel 2 lb tripped force - 0.50 Inch
 - 9F60: 0.125 lb tripped force - 0.20 Inch
- Many parts offered in non-indicating versions for use in Class 1, Div 2 environments.
- Hook-eye option featured on some models for non-load break isolation by hookstick.
 - A051F part numbers include welded hook-eye feature and are designed for use in Eaton Ampgard MCC, and direct replacement for 5ACLS series Eaton fuses
 - Optional hook-eye is also available on A480 part numbers, factory installed.

Ratings:

Amp-Trap

A240R

- **Volts:** 2.4kVAC
- **Amps:** 1 to 36R
- **IR:** 65kA Sym

A480R

- **Volts:** 4.8kVAC
- **Amps:** 2 to 36R
- **IR:** 64-65kA

A051F

- **Volts:** 5.08kV
- **Amps:** 2 to 24R
- **IR:** 50kA Sym

A072F

- **Volts:** 7.2kVAC
- **Amps:** 2 to 24R
- **IR:** 65kA Sym

9F60 SERIES TYPE EJ-2

9F60

- **Volts:** 2.54kVAC, 5.08kVAC
- **Amps:** 2 to 36R
- **IR:** 50kA Sym

APPLICATIONS:

- Short circuit protection of medium voltage motors and motor controllers.

APPROVALS:



- Amp-Trap: UL File E93367
- 9F60: UL File E191980

DEFINITIONS:

R-Rating: R-Rated fuses are back-up fuses that operate as follows (Per IEEE C37.42-2016): An R-Rated fuse will melt in the range of 15 to 35 seconds at a value of current equal to 100 times the “R” rating.

Back-up Current-Limiting Fuses: A back-up current-limiting fuse is a fuse that can interrupt any current between its rated minimum interrupting current and its maximum interrupting current. Back-up fuses are not designed or intended to open under overload conditions.

Continuous Ampere Rating at 40°C: The continuous amp rating defines the thermal capability of the fuse per IEEE C37.42-2016 and should not be the sole factor in fuse selection.

2.4kV FERRULE MOUNTED FUSES:



2.4kV R-Rated Amp-Trap Series

7.5" (191 mm) Clip Centers – Barrel diameter size D (3")

Catalog No.	Size	Continuous Amp rating at 40°C	Minimum Interrupting Rating RMS Amp	No of Barrels	Fig.	Indicating	Dimension L Inches (mm)	1 Phase interrupting rating	
								UL Component Recognition Max IR RMS Sym	Max Voltage Tested Max IR RMS Sym
A240R1R	1R	35	100	1	A	Yes	10.88 [276]	65kA at 2.6kV	65kA at 2.6kV
A240R2R	2R	70	170						
A240R3R	3R	100	250						
A240R4R	4R	130	340						
A240R5R	5R	150	420						
A240R6R	6R	170	500						
A240R9R	9R	200	760						
A240R12R	12R	230	1000						
A240R18R	18R	390	1500	2	B				
A240R24R	24R	450	2000						
A240R36R	36R**	650	2900	3	C				

** Not recommended for use in fuse clips which grasp only one barrel.

2.4kV / 2.54kV Ferrule mounted fuses:

Indicator Flush with Surface

2 Lb. Force (Tripped)

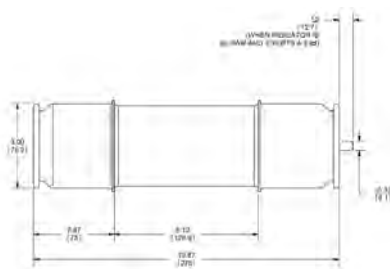

Figure A

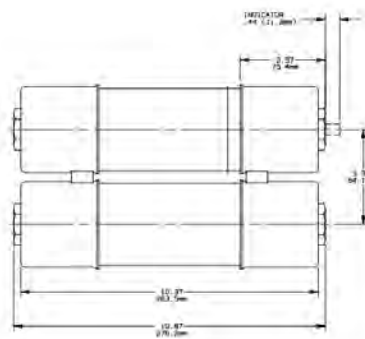

Figure B

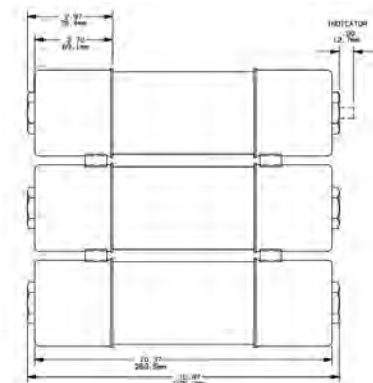

Figure C

2.4kV AND 5.08kV FERRULE MOUNTED FUSES:

2.4kV R-Rated 9F60 EJ-2 Series

7" (179 mm) Clip Centers - Barrel diameter size D (3")



Catalog No.	Size	Continuous Amp rating at 40°C	Minimum Interrupting Rating RMS Amp	No of Barrels	Fig.	Indicating	Dimension L Inches (mm)	1 Phase interrupting rating	
								UL Component Recognition Max IR RMS Sym	Max Voltage Tested Max IR RMS Sym
9F60LCB502	2R	70	195	1	D	Yes	10.88 [276]	50kA at 2.54kV	50kA at 2.54kV
9F60LCB503	3R	100	270						
9F60LCB504	4R	130	370						
9F60LCB506	6R	170	580						
9F60LCB509	9R	200	820						
9F60LCB512	12R	230	1150						
9F60MCB518	18R	390	1800	2	E				
9F60MCB524	24R	450	2400						
9F60LCL302	2R	70	195	1	D	No	10.88 [276]	50kA at 2.54kV	50kA at 2.54kV
9F60LCL303	3R	100	270						
9F60LCL304	4R	130	370						
9F60LCL306	6R	170	580						
9F60LCL309	9R	200	820						
9F60LCL312	12R	230	1150						
9F60MCL318	18R	390	1800	2	E				
9F60MCL324	24R	450	2400						

5.08kV R-Rated 9F60 EJ-2 Series

12" (305 mm) Clip Centers - Barrel diameter size D (3")

Catalog No.	Size	Continuous Amp rating at 40°C	Minimum Interrupting Rating RMS Amp	No of Barrels	Fig.	Indicating	Dimension L Inches (mm)	1 Phase interrupting rating	
								UL Component Recognition Max IR RMS Sym	Max Voltage Tested Max IR RMS Sym
9F60LJD502	2R	70	195	1	D	Yes	15.97 [406]	50kA at 5.08kV	50kA at 5.08kV
9F60LJD503	3R	100	270						
9F60LJD504	4R	130	370						
9F60LJD506	6R	170	580						
9F60LJD509	9R	200	820						
9F60LJD512	12R	230	1150						
9F60MJD518	18R	390	1800	2	E				
9F60MJD524	24R	450	2400						
9F60LJN302	2R	70	195	1	D	No	15.97 [406]	50kA at 5.08kV	50kA at 5.08kV
9F60LJN303	3R	100	270						
9F60LJN304	4R	130	370						
9F60LJN306	6R	170	580						
9F60LJN309	9R	200	820						
9F60LJN312	12R	230	1150						
9F60MJN318	18R	390	1800	2	E				
9F60MJN324	24R	450	2400						

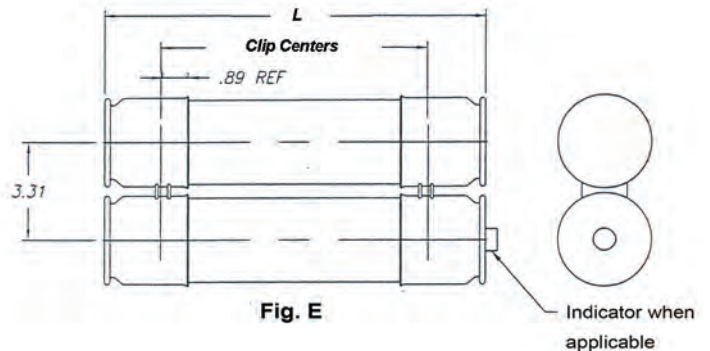
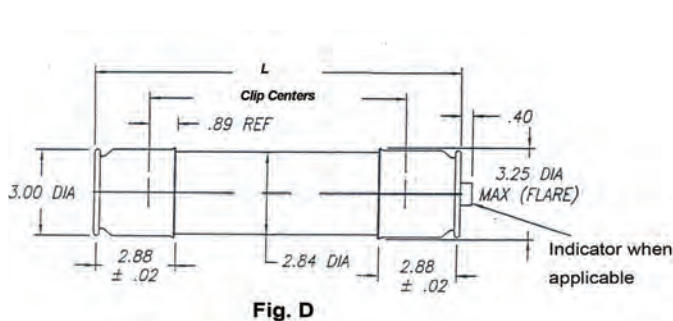

4.8kV / 5.08kV FERRULE MOUNTED FUSES:

4.8kV R-Rated Amp-Trap Series

12.5" (317 mm) Clip Centers - Barrel diameter size D (3")



Catalog No.	Size	Continuous Amp rating at 40°C	Minimum Interrupting Rating RMS Amp	No of Barrels	Fig.	Indicating	Dimension L Inches (mm)	1 Phase interrupting rating	
								UL Component Recognition Max IR RMS Sum	Max Voltage Tested Max IR RMS Sum
A480R2R-1	2R	70	190	1	F	Yes	15.88 (403)	65kA at 5.5kV	65kA at 5.5kV
A480R3R-1	3R	100	225						
A480R4R-1	4R	130	330						
A480R5R-1	5R	150	400						
A480R6R-1	6R	170	500						
A480R9R-1	9R	200	740						
A480R12R-1	12R	230	955	2	G		64kA at 5.5kV	64kA at 5.5kV	
A480R18R-1	18R	390	1440						
A480R24R-1	24R	450	1910						
A480R36R-1	36R**	650	2810	3	H				

** Not recommended for use in fuse clips which grasp only one barrel.

4.8kV R-Rated Amp-Trap Series with Hookeye

12.75" (324 mm) Clip Centers - Barrel diameter size D (3")



Catalog No.	Size	Continuous Amp rating at 40°C	Minimum Interrupting Rating RMS Amp	No of Barrels	Fig.	Indicating	Dimension L Inches (mm)	1 Phase interrupting rating	
								UL Component Recognition Max IR RMS Sum	Max Voltage Tested Max IR RMS Sum
A480R2R-1HE	2R	70	190	1	F	Yes	16.13 (410)	50kA at 5.08kV	63kA at 5.5kV
A480R3R-1HE	3R	100	225						
A480R4R-1HE	4R	130	330						
A480R5R-1HE	5R	150	400						
A480R6R-1HE	6R	170	500						
A480R9R-1HE	9R	200	740						
A480R12R-1HE	12R	230	955	2	G				
A480R18R-1HE	18R	390	1440						
A480R24R-1HE	24R	450	1910						

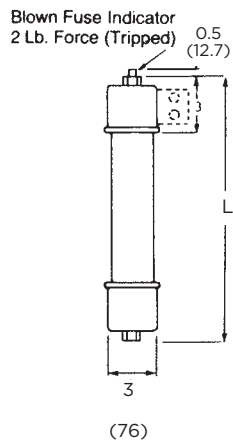

Figure F

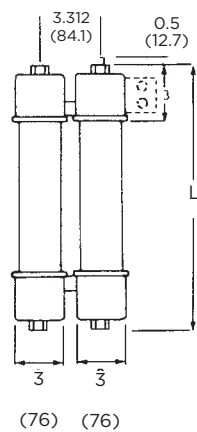

Figure G

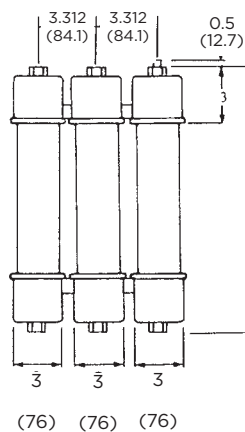
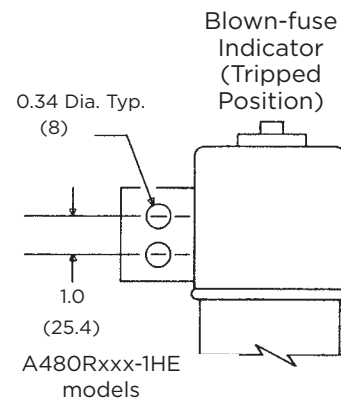

Figure H



4.8kV / 5.08kV FERRULE MOUNTED FUSES:

5.08kV R-Rated Amp-Trap Ferrule Mount w/ Hookeye, for use in Ampgard Switchgear



Catalog No.	Size	Continuous Amp rating at 40°C	Rated Minimum Interrupting Current	No of Barrels	Fig.	Indicating	Dimension L Inches (mm)	UL Component Recognition Max IR RMS Sym	Max Voltage Tested Max IR RMS Sym
A051F1DHRO – 2R	2R	70	200	1	I	Yes**	15.88 [403.2]	50kA @5.08kV	50kA @5.08kV
A051F1DHRO – 3R	3R	100	290						
A051F1DHRO – 4R	4R	130	360						
A051F1DHRO – 5R	5R	150	450						
A051F1DHRO – 6R	6R	170	600						
A051F1DHRO – 9R	9R	200	900						
A051F1DHRO – 12R	12R	230	1200	2	J				
A051F2DHRO – 18R	18R	390	1500						
A051F2DHRO – 24R	24R	450	2200						

** All part numbers available without indication by substituting “DHRO” w/ “DHRN”. Example: A051F1DHRN-24R

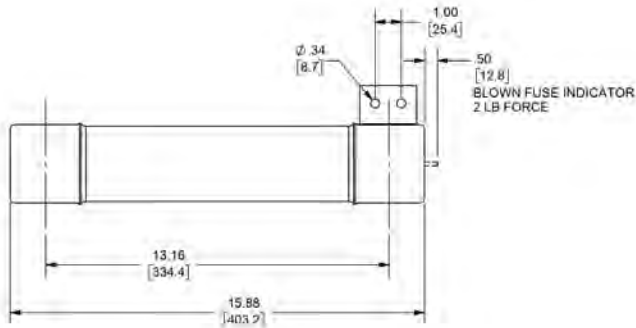

Figure I

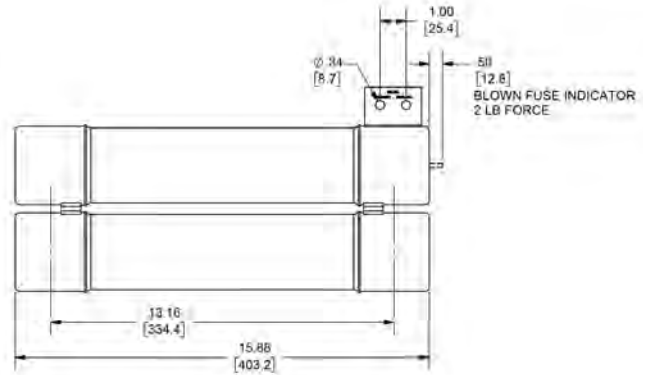

Figure J



7.2kV FERRULE MOUNTED FUSES:

7.2kV R-Rated Amp-Trap Series

12.5" (317 mm) Clip Centers - Barrel diameter size D (3")



Catalog No.	Size	Continuous Amp rating at 40°C	Minimum Interrupting Rating RMS Amp	No of Barrels	Fig.	Indicating	Dimension L Inches (mm)	1 Phase interrupting rating	
								UL Component Recognition	Max Voltage Tested
								Max IR RMS Sym	Max IR RMS Sym
A072F1D0R0-2R	2R	70	190	1	L	Yes	15.88 (403)	65kA at 7.2kV	65kA at 7.7kV
A072F1D0R0-3R	3R	100	225						
A072F1D0R0-4R	4R	130	330						
A072F1D0R0-5R	5R	150	400						
A072F1D0R0-6R	6R	170	500						
A072F1D0R0-9R	9R	200	740						
A072F1D0R0-12R	12R	230	955	2	M				
A072F2D0R0-18R	18R	390	1440						
A072F2D0R0-24R	24R	450	1910						

MV

Indicator Flush with Surface
2 Lb. Force (Tripped)

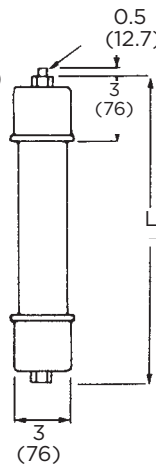

Figure L

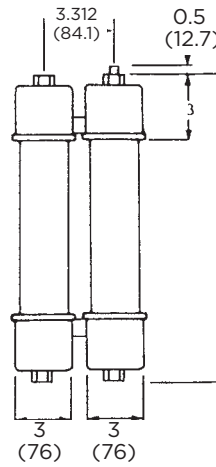

Figure M

Motor Protection

Amp-Trap® Bolt-In Series

MEDIUM VOLTAGE FUSES

5.08kV, 7.2kV AND 15.5kV
BOLT-IN FUSES



Mersen R-Rated fuses are current-limiting, high interrupting rating fuses intended for the short circuit protection of medium voltage motors and motor control centers (MCC). R-Rated fuses are back-up fuses that have a minimum interrupting rating, and must be coordinated with overload relays in MCCs. These fuses are single, double, triple or quadruple barrels 3 inches diameter with end mounts designed for bolting directly to equipment bus or terminal pads. Used in and requested for replacement in MCCs from many manufacturers.

FEATURES/BENEFITS:

- The Amp-Trap Bolt-in series are UL Recognized.
- Bolt-in mounting for direct connection to bus or terminals.
- Current-limiting for superior equipment protection.
- Metal embossed catalog number and manufacturing date for lasting identification.
- Blown-fuse indicator to give positive identification of open fuse:
 - Amp-Trap: 3" Barrel 2 lb tripped force - 0.50 inch (0.38 inch for -DHR0 part numbers)
 - 9F60: 0.125 lb tripped force - 0.2 inch

Ratings:

Amp-Trap

A051B

- **Volts:** 5.08kV AC
- **Amps:** 2 to 38R
- **IR:** 50kA Sym, 65kA Sym

A072B

- **Volts:** 7.2kV AC
- **Amps:** 2 to 24R, 19R to 57X
- **IR:** 50kA Sym, 65kA Sym

A155B

- **Volts:** 15.5kV AC
- **Amps:** 9 to 38X
- **IR:** 50kA Sym

9F60 Series Type EJ-2

- **Volts:** 5.08kV
- **Amps:** 2 to 24R
- **IR:** 50kA Sym

APPLICATIONS:

- Short circuit protection of medium voltage motors and motor controllers.
- Bolt-in equipment for secure mechanical connection in blast-proof equipment
- Many parts offered in non-indicating versions for use in Class 1, Div 2 locations

APPROVALS:

- UL Recognized File E93367



DEFINITIONS:

R-Rating: R-Rated fuses are back-up fuses that operate as follows (Per IEEE C37.42-2016): An R-Rated fuse will melt in the range of 15 to 35 seconds at a value of current equal to 100 times the “R” rating.

Back-up Current-Limiting Fuses: A back-up current-limiting fuse is a fuse that can interrupt any current between its rated minimum interrupting current and its maximum interrupting current. Back-up fuses are not designed or intended to open under overload conditions.

Continuous Ampere Rating at 40°C: The continuous amp rating defines the thermal capability of the fuse per IEEE C37.42-2016 and should not be the sole factor in fuse selection.

5.08kV / 7.2kV BOLT-IN FUSES:

5.08kV R-Rated Amp-Trap Bolt-In Series



Catalog No.	Size	Continuous Amp rating at 40°C	Minimum Interrupting Rating RMS Amp	No of Barrels	Fig.	Indicating	1 Phase interrupting rating	
							UL Component Recognition Max IR RMS Sym	Max Voltage Tested Max IR RMS Sym
A051B1DARO-2R	2R	70	190	1	A	Yes	65kA at 5.08kV	65kA at 5.5kV
A051B1DARO-3R	3R	100	225					
A051B1DARO-4R	4R	130	330					
A051B1DARO-6R	6R	170	500					
A051B1DARO-9R	9R	200	740					
A051B1DARO-12R	12R	230	955	2	B	Yes	65kA at 5.08kV	65kA at 5.5kV
A051B2DARO-18R	18R	390	1440					
A051B2DARO-24R	24R	450	1910					
A051B2DARO-32R	32R	600	2500					
A051B2DARO-38R	38R	700	3100	3	C	Yes	50kA at 5.08kV	50kA at 5.2kV
A051B3DARO-48X	48X	750	3600					
A051B3DARO-57X	57X	900	4500					

7.2kV R-Rated Amp-Trap Bolt-In Series



Catalog No.	Size	Continuous Amp rating at 40°C	Minimum Interrupting Rating RMS Amp	No of Barrels	Fig.	Indicating	1 Phase interrupting rating	
							UL Component Recognition Max IR RMS Sym	Max Voltage Tested Max IR RMS Sym
A072B1DARO-2R	2R	70	190	1	A	Yes	65kA at 7.2kV	65kA at 7.7kV
A072B1DARO-3R	3R	100	225					
A072B1DARO-4R	4R	130	330					
A072B1DARO-5R	5R	150	400					
A072B1DARO-6R	6R	170	500					
A072B1DARO-9R	9R	200	740	2	B	Yes	65kA at 7.2kV	65kA at 7.7kV
A072B1DARO-12R	12R	230	955					
A072B2DARO-18R	18R	390	1440					
A072B2DARO-24R	24R	450	1910					

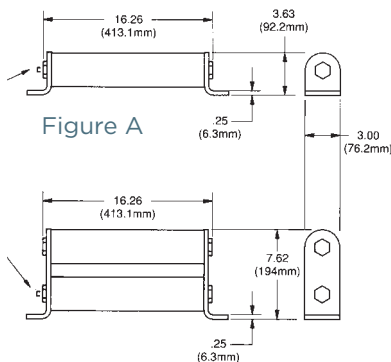

Figure B

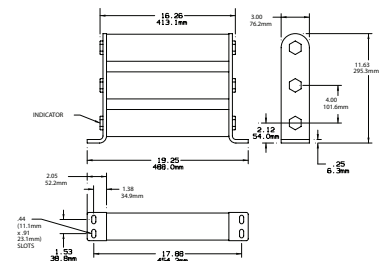
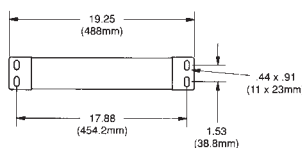

Figure C

5.08kV / 7.2kV BOLT-IN FUSES:

5.08kV R-Rated 9F60, EJ-2 Bolt-In Series, for use in Mebane Style Switchgear

Catalog No.	Size	Continuous Amp rating at 40°C	Rated Minimum Interrupting Current	No of Barrels	Figure	Indicating	Dimension L Inches/ (mm)	UL Component Recognition Max IR RMS Sym	Max Voltage Tested Max IR RMS Sym
9F60LXD702	2R	70	195	1	D	Yes		50kA at 5.08kV	50kA at 5.08kV
9F60LXD703	3R	100	270						
9F60LXD704	4R	130	370						
9F60LXD706	6R	170	580						
9F60LXD709	9R	200	820						
9F60LXD712	12R	230	1150						
9F60MXD718	18R	390	1800	2	E				
9F60MXD724	24R	450	2400						

** All part numbers available without indication by substituting "DHRO" w/ "DHRN". Example: A051B1DHRN-24R

5.08kV R-Rated 9F60, EJ-2 Bolt-In Series, for use in Mebane Style Switchgear - Alternate Bolt Configuration

Catalog No.	Size	Continuous Amp rating at 40°C	Rated Minimum Interrupting Current	No of Barrels	Figure	Indicating	Dimension L Inches/ (mm)	UL Component Recognition Max IR RMS Sym	Max Voltage Tested Max IR RMS Sym
9F60LXD402	2R	70	195	1	F	Yes		50kA at 5.08kV	50kA at 5.08kV
9F60LXD403	3R	100	270						
9F60LXD404	4R	130	370						
9F60LXD406	6R	170	580						
9F60LXD409	9R	200	820						
9F60LXD412	12R	230	1150						
9F60MXD418	18R	390	1800	2	G				
9F60MXD424	24R	450	2400						

** All part numbers available without indication by substituting "DHRO" w/ "DHRN". Example: A051B1DHRN-24R

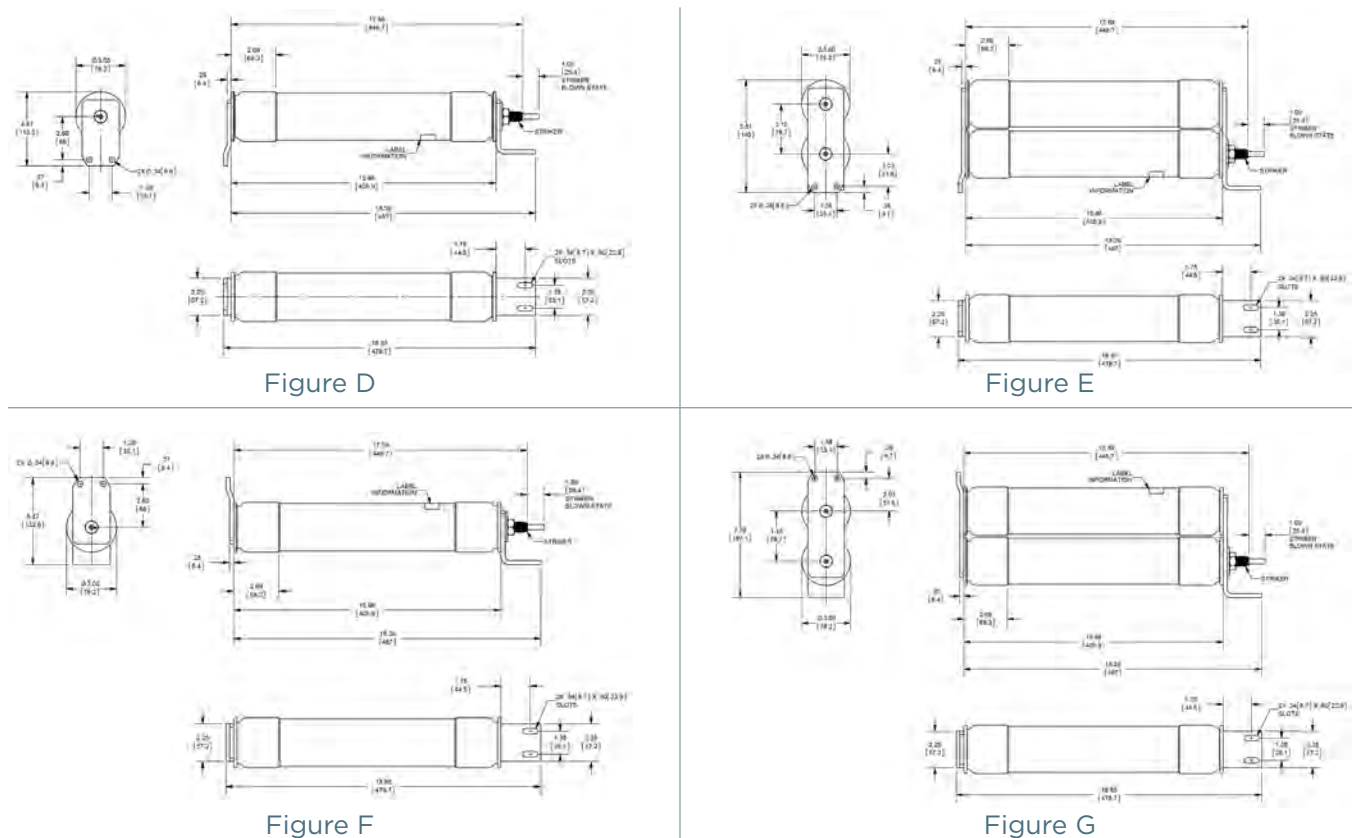



5.08kV / 7.2kV BOLT-IN FUSES:

5.08kV R-Rated Amp-Trap Bolt-In Series, for use in Ampgard Switchgear

Catalog No.	Size	Continuous Amp rating at 40°C	Rated Minimum Interrupting Current	No of Barrels	Fig.	Indicating	Dimension L Inches/ [mm]	UL Component Recognition	Max Voltage Tested	
								Max IR RMS Sym	Max IR RMS Sym	
A051B1DHRO – 2R	2R	70	200	1	H	Yes**	15.88 [403.2]	50kA @5.08kV	50kA @5.08kV	
A051B1DHRO – 3R	3R	100	290							
A051B1DHRO – 4R	4R	130	360							
A051B1DHRO – 5R	5R	150	450							
A051B1DHRO – 6R	6R	170	600							
A051B1DHRO – 9R	9R	200	900	2	I					
A051B1DHRO – 12R	12R	230	1200							
A051B2DHRO – 18R	18R	390	1500							
A051B2DHRO – 24R	24R	450	2200							

** All part numbers available without indication by substituting "DHRO" w/ "DHRN". Example: A051B1DHRN-24R

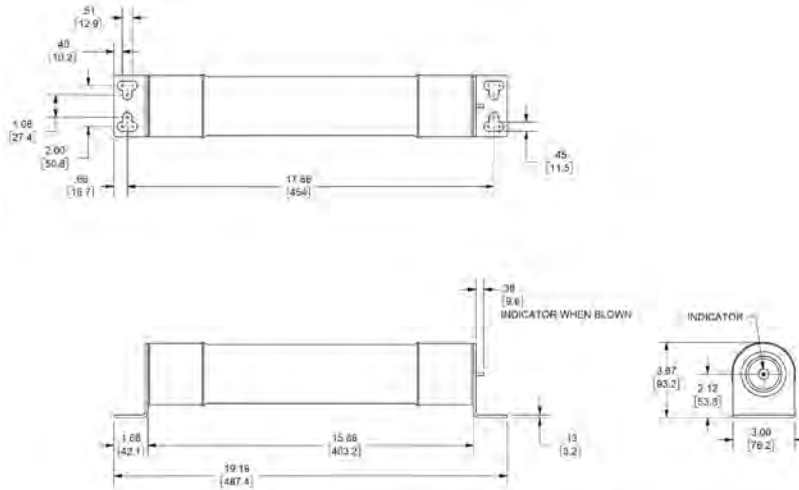

Figure H

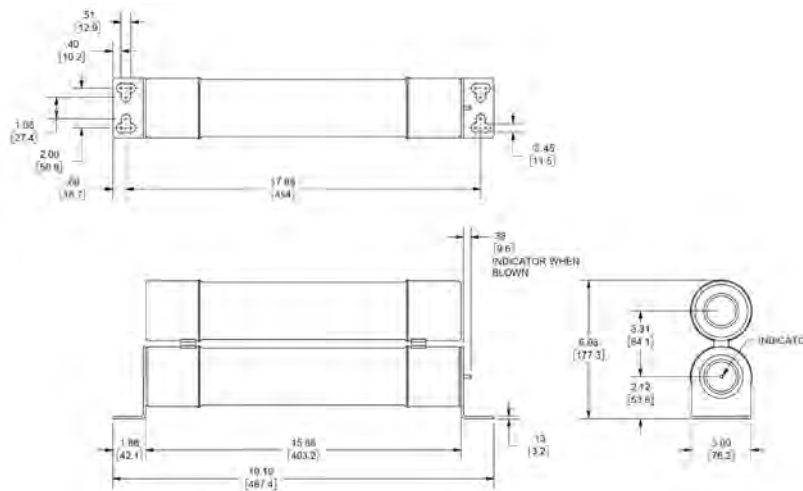

Figure I

MV



7.2kV / 15.5kV BOLT-IN FUSES:

7.2kV R-Rated Amp-Trap Bolt-In Series

Catalog No.	Size	Continuous Amp rating at 40°C	Minimum Interrupting Rating RMS Amp	Indicating	1 Phase interrupting rating		No of Barrels	Fig.
					UL Component Recognition Max IR RMS Sym	Max Voltage Tested Max IR RMS Sym		
A072B1D0R0-19R	19R	300	1560	Yes	65kA at 7.2kV	65kA at 7.66kV	1	J
A072B2D0R0-32R	32R	540	3070			65kA at 7.66kV	2	K
A072B2D0R0-38R	38R	600	3480			65kA at 7.66kV	3	L
A072B3DBR0-48X	48X	750	4360			65kA at 7.2kV	3	L
A072B3DBR0-57X	57X	900	5000			65kA at 7.2kV	3	L

15.5kV R-Rated Amp-Trap Bolt-In Series



Catalog No.	Size	Continuous Amp rating at 40°C	Minimum Interrupting Rating RMS Amp	Indicating	1 Phase interrupting rating		No of Barrels	Fig.
					UL Component Recognition Max IR RMS Sym	Max Voltage Tested Max IR RMS Sym		
A155B2D0R0-9R	9R	200	888	Yes	50 kA at 15.5kV	50 kA at 15.5kV	2	M
A155B2D0R0-12R	12R	230	1200				3	N
A155B3D0R0-18X	18X	390	1900				4	0
A155B3D0R0-24X	24X	450	2633					
A155B4D0R0-32X	32X	600	3510					
A155B4D0R0-38X	38X	700	4000					

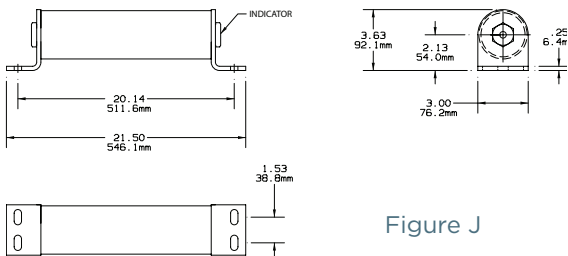

Figure J

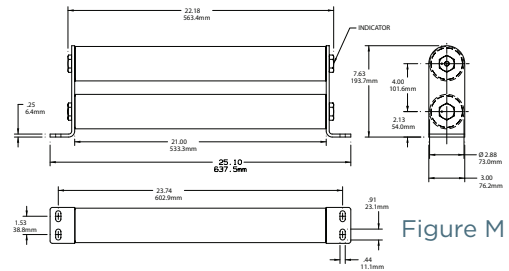

Figure M

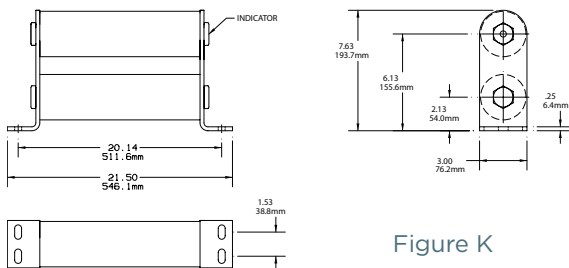

Figure K

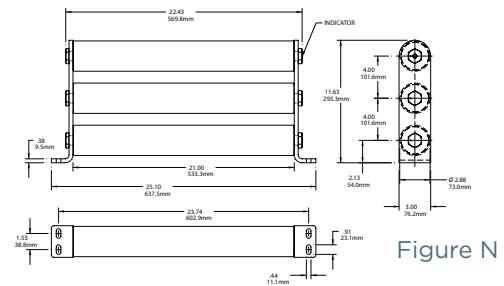

Figure N

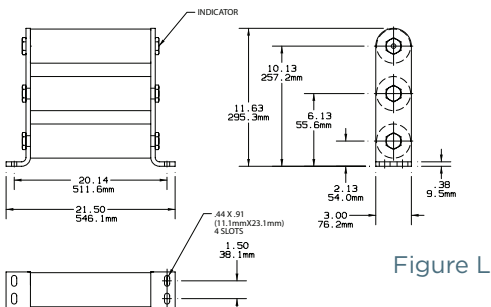

Figure L

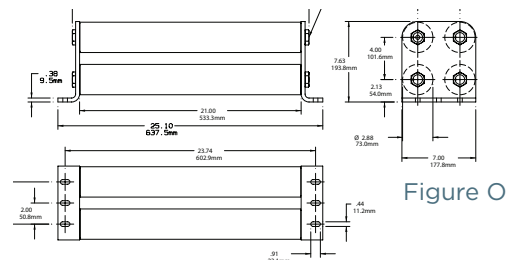

Figure O

Motor Protection

Amp-Trap® DIN-Style Fuses

MEDIUM VOLTAGE FUSES

R-RATED IEC DIN STYLE MV FUSES

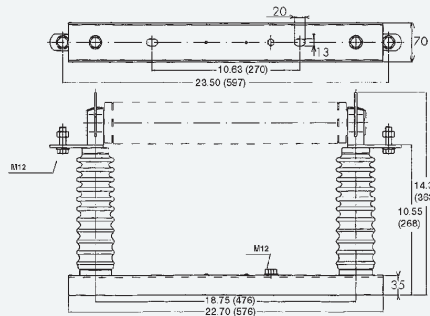

Amp-Trap® R-Rated DIN style fuses are current-limiting, high interrupting rating fuses, intended for the short circuit protection of medium voltage motors and motor controllers. This product range offers North American R-Rated performance in the IEC 282-1 DIN mounting configuration of 442mm. R-Rated fuses are applied as back up fuses that have a minimum interrupting rating, and must be coordinated with overload relays in combination motor starters. Amp-Trap R-Rated, DIN type fuses are offered in voltage ratings of 3.3kV, 5.5kV and 7.2kV in ratings from 2R to 19R. All fuses within this product group are UL component recognized.

DEFINITIONS:

R-Rating: R-Rated fuses are back-up fuses that operate as follows (Per IEEE C37.42-2016): An R-Rated fuse will melt in the range of 15 to 35 seconds at a value of current equal to 100 times the “R” rating.

Back-up Current-Limiting Fuses: A back-up current-limiting fuse is a fuse that can interrupt any current between its rated minimum interrupting current and its maximum interrupting current. Back-up fuses are not designed or intended to open under overload conditions.

Continuous Ampere Rating at 40°C: The continuous amp rating defines the thermal capability of the fuse per IEEE C37.42-2016 and should not be the sole factor in fuse selection.

Spring-Reinforced Clip MR45 & Spring Ref.# L096472

Fuse-Holder: SI 24/442 Ref # K209424 In compliance with IEC 282-1, DIN standard 43625. * Note: Ratings above 19R may be achieved by paralleling fuses. Please consult factory for details.

RATINGS:

A033D1

- **Volts:** 3300V AC
- **Amps:** 2 to 19R*
- **IR:** 65kA Sym

A055D1

- **Volts:** 5500V AC
- **Amps:** 2 to 19R*
- **IR:** 65kA Sym

A072D1

- **Volts:** 7200V AC
- **Amps:** 2 to 19R*
- **IR:** 65kA Sym

FEATURES/BENEFITS:

- Clip mount DIN 45: R-Rated fuses with North American ANSI characteristics in a standard DIN 442mm size.
- Current-limiting for superior equipment protection
- Blown fuse indicator provides positive identification of open fuse. 4.5lb tripping force - 1.0”.

HIGHLIGHTS:

- R-Rated
- UL recognized

APPLICATIONS:

- Short circuit protection of medium voltage motors and motor controllers.

APPROVALS:

- UL recognized component File E93367



Fig.	Catalog Number	Size	Continuous Amp Rating 55 ° C**	Continuous Amp Rating 40 ° C**	Minimum Interrupting Rating RMS Rating	1 Phase Interrupting Rating Maximum Tested	
						RMS Asym	RMS Sym
3.3kv Max. DIN IEC Style 442 mm							
A	A033D1DSR0-2R	2R	63	70	190	100kA @ 3300V	65kA @ 3300V
A	A033D1DSR0-3R	3R	90	100	225		
A	A033D1DSR0-4R	4R	115	130	225		
A	A033D1DSR0-5R	5R	135	150	400		
A	A033D1DSR0-6R	6R	150	170	540		
A	A033D1DSR0-9R	9R	180	200	780		
A	A033D1DSR0-12R	12R	210	230	955		
A	A033D1DSR0-13R	13R*	230	260	1050		
A	A033D1DSR0-16R	16R*	270	300	1200		
A	A033D1DSR0-19R	19R*	280	310	1280		
5.5kv Max. DIN IEC Style 442 mm							
A	A055D1DSR0-2R	2R	63	70	190	100kA @ 5500V	65kA @ 5500V
A	A055D1DSR0-3R	3R	90	100	225		
A	A055D1DSR0-4R	4R	115	130	225		
A	A055D1DSR0-5R	5R	135	150	400		
A	A055D1DSR0-6R	6R	150	170	540		
A	A055D1DSR0-9R	9R	180	200	780		
A	A055D1DSR0-12R	12R	210	230	955		
A	A055D1DSR0-13R	13R*	230	260	1050		
A	A055D1DSR0-16R	16R*	270	300	1200		
A	A055D1DSR0-19R	19R*	280	310	1280		
7.2kv Max. DIN IEC Style 442 mm							
A	A072D1DSR0-2R	2R	63	70	190	100kA @ 7200V	65kA @ 7200V
A	A072D1DSR0-3R	3R	90	100	225		
A	A072D1DSR0-4R	4R	115	130	400		
A	A072D1DSR0-5R	5R	135	150	540		
A	A072D1DSR0-6R	6R	150	170	550		
A	A072D1DSR0-9R	9R	180	200	780		
A	A072D1DSR0-12R	12R	210	230	955		
A	A072D1DSR0-13R	13R*	230	260	1050		
A	A072D1DSR0-16R	16R*	270	300	1200		
A	A072D1DSR0-19R	19R*	280	310	1280		

* 13R, 16R and 19R are not standard ratings defined in IEEE C37.42.

** This rating defines the thermal capability of the fuse per IEEE C37.42 and should not be the sole factor in fuse selection.

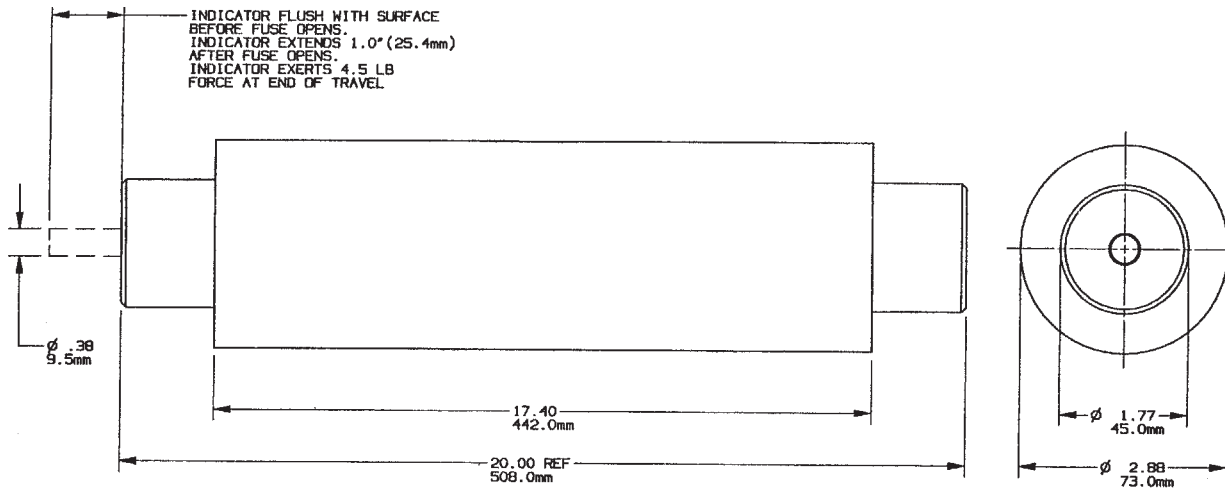

Figure A



Potential Transformer

Amp-Trap® and 9F60 Series PT Fuses

MEDIUM VOLTAGE FUSES

0.625kV – 2.4kV – 2.75kV – 4.8kV – 5.0kV – 5.5kV – 7.2kV – 8.25kV AND
15.5kV FERRULE MOUNTED FUSES

M
V



Mersen PT fuses are current-limiting fuses with high interrupting rating, used for the primary winding protection of potential transformer. They are small dimension ferrule type fuses and mount in standard clips. Current ratings are from 0.25A to 5A.

FEATURES/BENEFITS:

- Ferrule mounting for standard clips and interchangeability with other brands of fuses.
- Current-limiting for superior equipment protection.
- Non-venting for silent operation.
- Metal embossed catalog number and manufacturing date for lasting identification.
- Blown-fuse indicator to give positive identification of open fuse fuse is available on the 9F60 series.

APPLICATIONS:

- Primary protection for potential transformers (PT) or control power transformers (CPT).

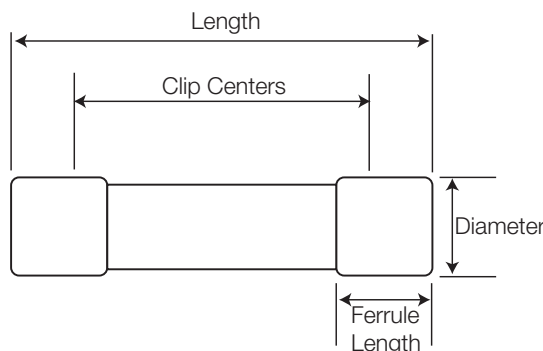

RATINGS:

Amp-Trap

A240T

- **Volts:** 2.4kVAC
- **Amps:** 0.5 to 5A
- **IR:** 50kA Sym

A480T

- **Volts:** 4.8kVAC
- **Amps:** 0.5 to 5A
- **IR:** 80kA Sym

A500T

- **Volts:** 5.0kVAC
- **Amps:** 0.25 to 5A
- **IR:** 80kA Sym

A720T

- **Volts:** 7.2kVAC
- **Amps:** 0.5 to 3A
- **IR:** 50kA Sym

9F60 Series EJ-1

9F60A

- **Volts:** .625kVAC
- **Amps:** 3 to 5A
- **IR:** 100kA Sym

9F60B

- **Volts:** 2.75kVAC, 5.5kVAC, 8.25kVAC, 15.5kVAC
- **Amps:** 0.5 to 3A
- **IR:** 52kA Sym, 63kA Sym, 50kA Sym, 120kA Sym

0.625kV / 2.4kV / 2.75kV FERRULE MOUNTED FUSES:

0.625kV Potential Transformer fuses – 9F60 Series, EJ-1

4.25" (108 mm) Clip Centers

Catalog No.	Amp Rating	Indicating	Diameter Inches (mm)	Length Inches (mm)	Ferrule Length Inches (mm)	Max Voltage	Max IR RMS Sym	Spare Parts (Clips*)	Spare Parts (Live Parts)	Fuse Support Indoor (EK-1)
9F60AAA003	3A	Yes	0.812 [20.6]	4.625 [117.5]	1.12 [28.4]	.625 kV	100kA	C08917P	–	–
9F60AAA005	5A									
9F60AAA007	7A									
9F60AAA010	10A									

2.4kV Potential Transformer fuses – Amp-Trap Series

4.00" (102 mm) Clip Centers

Catalog No.	Amp Rating	Indicating	Diameter Inches (mm)	Length Inches (mm)	Ferrule Length Inches (mm)	Max Voltage	Max IR RMS Sym	Spare Parts (Clips*)	Spare Parts (Live Parts)	Fuse Support Indoor (EK-1)
A240T1/2E	0.5A	No	0.812 [20.6]	4.625 [117.5]	0.625 [15.9]	2.4kV	50kA	C08917P	–	–
A240T1E	1A									
A240T2E	2A									
A240T5E	5A									

2.75kV Potential Transformer fuses – 9F60 Series, EJ-1

4.25" (108 mm) Clip Centers

Catalog No.	Amp Rating	Indicating	Diameter Inches (mm)	Length Inches (mm)	Ferrule Length Inches (mm)	Max Voltage	Max IR RMS Sym	Spare Parts (Clips*)	Spare Parts (Live Parts)	Fuse Support Indoor (EK-1)
9F60AAB001	1A	Yes	0.812 [20.6]	4.625 [117.5]	1.12 [28.4]	2.75kV	52kA	C08917P	–	–
9F60AAB002	2A									

2.75kV Potential Transformer fuses – 9F60 Series, EJ-1

6" (152 mm) Clip Centers

Catalog No.	Amp Rating	Indicating	Diameter Inches (mm)	Length Inches (mm)	Ferrule Length Inches (mm)	Max Voltage	Max IR RMS Sym	Spare Parts (Clips*)	Spare Parts (Live Parts)	Fuse Support Indoor (EK-1)
9F60BBB001	1A	Yes	1.562 [40]	7.375 [187]	1.31 [33.3]	2.75kV	52kA	9F61BWW460	9F61BNW450	–
9F60BBB002	2A									
9F60BBB003	3A									

2.75kV Potential Transformer fuses – 9F60 Series, EJ-1

8.12" (206 mm) Clip Centers

Catalog No.	Amp Rating	Indicating	Diameter Inches (mm)	Length Inches (mm)	Ferrule Length Inches (mm)	Max Voltage	Max IR RMS Sym	Spare Parts (Clips*)	Spare Parts (Live Parts)	Fuse Support Indoor (EK-1)
9F60BDB001	1A	Yes	1.562 [40]	9.5 [241]	1.31 [33.3]	2.75 kV	52kA	9F61BWW460	9F61BNW450	9F61ABB101
9F60BDB002	2A									
9F60BDB003	3A									

**Use two clips per fuse*



4.8kV / 5kV / 5.4kV FERRULE MOUNTED FUSES:

4.8kV Potential Transformer fuses - Amp-Trap Series

5" (127 mm) Clip Centers

Catalog No.	Amp Rating	Indicating	Diameter Inches (mm)	Length Inches (mm)	Ferrule Length Inches (mm)	Max Voltage	Max IR RMS Sym	Spare Parts (Clips*)	Spare Parts (Live Parts)	Fuse Support Indoor (EK-1)
A480T1/2E	0.5A	No	0.812 (20.6)	5.625 (143)	0.625 (15.9)	5.5kV	80kA	C08917P	-	-
A480T3/4E	0.75A									
A480T1E	1A									
A480T2E	2A									
A480T3E	3A									
A480T4E	4A									
A480T5E	5A									

5kV Potential Transformer fuses - Amp-Trap Series

5" (127 mm) Clip Centers

Catalog No.	Amp Rating	Indicating	Diameter Inches (mm)	Length Inches (mm)	Ferrule Length Inches (mm)	Max Voltage	Max IR RMS Sym	Spare Parts (Clips*)	Spare Parts (Live Parts)	Fuse Support Indoor (EK-1)
A500T1/4E-1	0.25A	No	1.00 (25.4)	5.625 (143)	0.563 (14.3)	5.5kV	80kA	-	-	-
A500T1/2E-1	0.5A									
A500T1E-1	1A									
A500T2E-1	2A									
A500T3E-1	3A									
A500T4E-1	4A									
A500T5E-1	5A									

5.5kV Potential Transformer fuses - 9F60 Series, EJ-1

6.00" (152 mm) Clip Centers

Catalog No.	Amp Rating	Indicating	Diameter Inches (mm)	Length Inches (mm)	Ferrule Length Inches (mm)	Max Voltage	Max IR RMS Sym	Spare Parts (Clips*)	Spare Parts (Live Parts)	Fuse Support Indoor (EK-1)
9F60BDD905	0.5A	Yes	1.562 (40)	7.375 (187)	1.31 (33.3)	5.5 kV	80kA	9F61BWW460	9F61BNW450	-
9F60BDD001	1A									
9F60BDD002	2A									
9F60BDD003	3A									
9F60BBN905	0.5A	No	1.562 (40)	7.375 (187)	1.31 (33.3)	5.5 kV	80kA	9F61BWW460	9F61BNW450	-
9F60BBN001	1A									
9F60BBN002	2A									
9F60BBN003	3A									

5.5kV Potential Transformer fuses - 9F60 Series, EJ-1

8.12" (206 mm) Clip Centers

Catalog No.	Amp Rating	Indicating	Diameter Inches (mm)	Length Inches (mm)	Ferrule Length Inches (mm)	Max Voltage	Max IR RMS Sym	Spare Parts (Clips*)	Spare Parts (Live Parts)	Fuse Support Indoor (EK-1)
9F60BDD905	0.5A	Yes	1.562 (40)	9.5 (241)	1.31 (33.3)	5.5 kV	63kA	9F61BWW460	9F61BNW450	9F61ABB101
9F60BDD001	1A									
9F60BDD002	2A									
9F60BDD003	3A									

*Use two clips per fuse

7.2kV / 8.25kV / 15.5kV FERRULE MOUNTED FUSES:

7.2kV Potential Transformer fuses – Amp-Trap Series

8.88" (227 mm) Clip Centers

Catalog No.	Amp Rating	Indicating	Diameter Inches (mm)	Length Inches (mm)	Ferrule Length Inches (mm)	Max Voltage	Max IR RMS Sym	Spare Parts (Clips*)	Spare Parts (Live Parts)	Fuse Support Indoor (EK-1)
A720T1/2E-1	0.5A	No	0.812 (20.6)	9.5 (241)	0.625 (15.9)	7.2kV	50kA	C08917P	-	-
A720T3/4-1	0.75A									
A720T1E-1	1A									
A720T2E-1	2A									
A720T3E-1	3A									

8.25kV Potential Transformer fuses – 9F60 Series, EJ-1

8.12" (206 mm) Clip Centers

Catalog No.	Amp Rating	Indicating	Diameter Inches (mm)	Length Inches (mm)	Ferrule Length Inches (mm)	Max Voltage	Max IR RMS Sym	Spare Parts (Clips*)	Spare Parts (Live Parts)	Fuse Support Indoor (EK-1)
9F60BDE905	0.5A	Yes	1.562 (40)	9.5 (241)	1.31 (33.3)	8.25 kV	80kA	9F61BWW460	9F61BNW450	9F61ABG101
9F60BDE001	1A									
9F60BDE002	2A									
9F60BDE003	3A									

15.5kV Potential Transformer fuses – 9F60 Series, EJ-1

11.5" (292 mm) Clip Centers

Catalog No.	Amp Rating	Indicating	Diameter Inches (mm)	Length Inches (mm)	Ferrule Length Inches (mm)	Max Voltage	Max IR RMS Sym	Spare Parts (Clips*)	Spare Parts (Live Parts)	Fuse Support Indoor (EK-1)
9F60BHH905	0.5A	Yes	1.562 (40)	12.875 (327)	1.31 (33.3)	15.5 kV	120kA	9F61BWW460	9F61BNW450	9F61ADG101 (13.8kV nominal - 95 kV BIL) 9F61ADJ101 (14.4kV nominal - 110kV BIL)
9F60BHH001	1A									
9F60BHH002	2A									
9F60BHH003	3A									

*Use two clips per fuse



Capacitor Protection

Amp-Trap® and 9F60 Series

MEDIUM VOLTAGE FUSES

MEDIUM VOLTAGE CAPACITOR FUSES



Mersen capacitor fuses are designed to IEEE C37-41. They are current-limiting operating without noise or discharge and are designed to be used indoors in a general purpose enclosure or outdoors in a weatherproof enclosure. These are non-disconnecting fuses requiring the use of a disconnect switch. These capacitor fuses provide both short circuit and overload protection and are intended to protect against capacitor case rupture or dielectric failure within the capacitor.

The various mounting configurations offer manufacturers a wide range of cost/space saving solutions and a large choice of equivalent products.

FEATURES/BENEFITS:

- High interrupting capacity
- Current limitation
- Blown-fuse indication
- Direct mount
- Clip style mount
- Bus mount
- Non-venting for silent operation

APPLICATIONS:

- Capacitor Protection
- Power Factor Correction Equipment
- Harmonic Filtering Equipment
- Induction Heating System
- High Power Drive
- Welders

CATALOG NUMBERING SYSTEM:

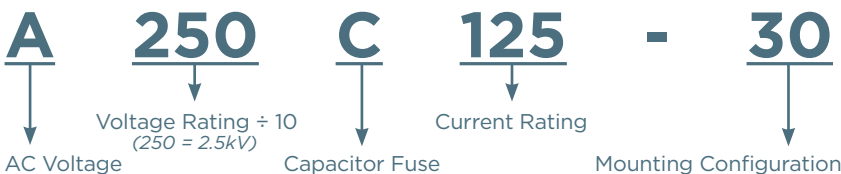

Ratings:

A100C

- **Volts:** 1000V AC Max.
- **Amps:** 25 to 125 A
- **IR:** 50 kA Sym

A150C

- **Volts:** 1500V AC Max.
- **Amps:** 25 to 200 A
- **IR:** 40 kA Sym

A250C

- **Volts:** 2500V AC Max.
- **Amps:** 25 to 200 A
- **IR:** 50 kA Sym

A300C

- **Volts:** 3000V AC Max.
- **Amps:** 50 to 175 A
- **IR:** 50 kA Sym

A430C

- **Volts:** 4300V AC Max.
- **Amps:** 6 to 100 A
- **IR:** 65 kA Sym

A550C

- **Volts:** 5500V AC Max.
- **Amps:** 6 to 75 A
- **IR:** 65 kA Sym

9F60RJD

- **Volts:** 5500V AC Max.
- **Amps:** 25 to 80 A
- **IR:** 50 kA Sym

9F60RJF

- **Volts:** 9520V AC Max.
- **Amps:** 15 to 40A
- **IR:** 50 kA Sym

1.0kV - 1.5kV CAPACITOR FUSES AMP-TRAP SERIES

Catalog Number	Ampere Rating	Melting I ² t (kA ² s)	Maximum 1 Clearing I ² t (kA ² s)	Maximum 1 Phase Interrupting Rating	Overall Length Inches (mm)	Tube Length Inches (mm)	Ind. Housing Inches (mm)	Body Dia Inches (mm)	Bracket Dimensions Inches (mm)	
1.5 kV Max Type 10 inner thread to screw					A	B	C	D	E	F
A150C25-10	25	4	12	40 kA @1500V RMS Sym	7.08 (179.8)	6.38 (162.1)	.70 (17.8)	1.42 (36.0)		
A150C50-10	50	16	50							
A150C60-10	60	25	70							
A150C75-10	75	35	110							
A150C90-10	90	50	150							
A150C100-10	100	65	200							
A150C110-10	110	80	250							
A150C120-10	120	100	310							
A150C125-10	125	125	330							
A150C130-10	130	125	330							
A150C135-10	135	130	350							
A150C140-10	140	130	350							
A150C150-10	150	150	390							
A150C160-10	160	185	480							
A150C165-10	165	185	480							
A150C175-10	175	225	600							
A150C200-10	200	300	800							
1.5 kV Max Type 20 screw to bolt (flat bracket)					A	B	C	D	E	F
A150C25-20	25	3.2	6.5	40 kA @1500V RMS Sym	6.84 (173.6)	5.73 (145.5)	1.42 (36.0)	1.10 (27.9)	3.00 (76.2)	1.25 (31.8)
A150C50-20	50	13	27							
A150C60-20	60	18	38							
A150C75-20	75	30	60							
A150C90-20	90	35	72							
A150C100-20	100	52	105							
A150C110-20	110	58	120							
A150C120-20	120	73	150							
A150C125-20	125	82	165							
A150C130-20	130	90	190							
A150C135-20	135	90	190							
A150C140-20	140	105	220							
A150C150-20	150	120	240							

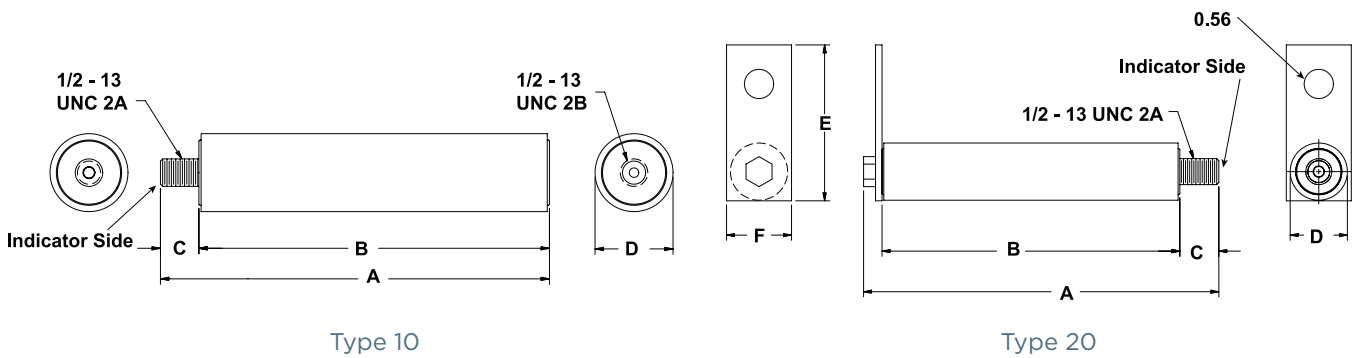

1.0kV - 1.5kV CAPACITOR FUSES AMP-TRAP SERIES

Catalog Number	Ampere Rating	Melting I ² t (kA ² s)	Maximum 1 Clearing I ² t (kA ² s)	Maximum 1 Phase Interrupting Rating	Overall Length Inches (mm)	Tube Length Inches (mm)	Ind. Housing Inches (mm)	Body Dia Inches (mm)	Bracket Dimensions Inches (mm)	
1.0 kV Max Type 30 external female to bolt (L bracket)					A	B	C	D	E	F
A100C25-30	25	4	10	50 kA @1000V RMS Sym	6.38 (162.1)	4.42 (112.3)	.75 (19.1)	1.10 (27.9)	5.76 (146.2)	1.25 (31.8)
A100C50-30	50	16	40							
A100C60-30	60	25	60							
A100C75-30	75	35	95							
A100C90-30	90	50	130							
A100C100-30	100	65	165							
A100C110-30	110	80	205							
A100C125-30	125	100	250							
1.5 kV Max Type 40 external female to external female					A	B	C	D	E	F
A150C100-40	100	125	140	40 kA @1500V RMS Sym	6.84 (173.6)	4.78 (121.4)	.51 (13.0)	1.75 (27.9)	.75 (19.1)	1.41 (35.8)
A150C110-40	110	125	180							
A150C125-40	125	130	230							
A150C130-40	130	130	230							
A150C140-40	140	150	285							
A150C150-40	150	185	315							
A150C160-40	160	185	360							
A150C175-40	175	225	410							
A150C200-40	200	300	560							
1.5 kV Max Type 50 screw to bolt (L bracket)					A	B	C	D	E	F
A150C50-50	50	13	27	40 kA @1500V RMS Sym	8.11 (206.0)	5.74 (145.8)	.75 (19.1)	1.10 (27.9)	7.49 (190.2)	1.25 (31.8)
A150C60-50	60	18	38							
A150C75-50	75	30	60							
A150C90-50	90	35	72							
A150C100-50	100	52	105							
A150C110-50	110	58	120							
A150C120-50	120	73	150							
A150C125-50	125	82	165							
A150C130-50	130	90	190							
A150C135-50	135	90	190							
A150C140-50	140	105	220							
A150C150-50	150	120	240							

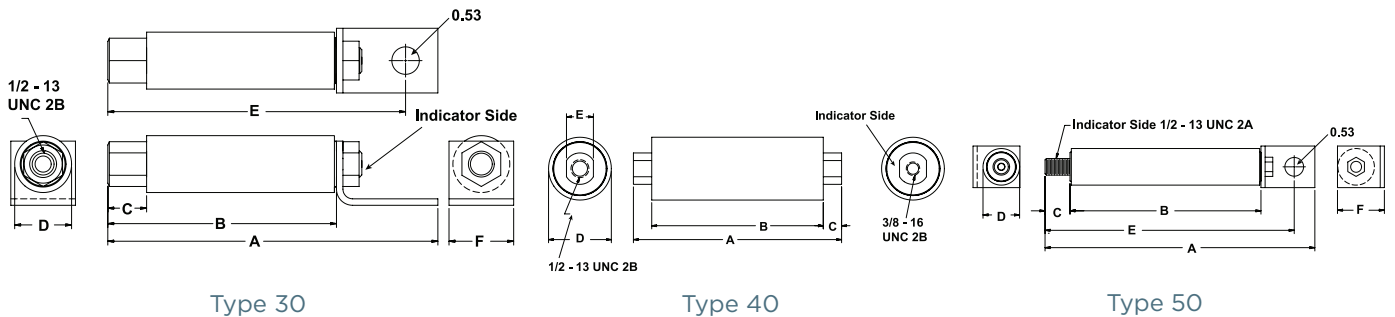

M
V

2.5kV CAPACITOR FUSES AMP-TRAP SERIES

Catalog Number	Ampere Rating	Melting I ² t (kA ² s)	Maximum 1 Clearing I ² t (kA ² s)	Maximum 1 Phase Interrupting Rating	Overall Length Inches (mm)	Tube Length Inches (mm)	Ind. Housing Inches (mm)	Body Dia Inches (mm)	Bracket Dimensions Inches (mm)	
2.5 kV Max Type 10 inner thread to screw					A	B	C	D	E	F
A250C25-10	25	3	9	50 kA @2500V RMS Sym	7.67 [194.8]	6.92 [175.8]	.75 [19.1]	1.42 [36.0]		
A250C50-10	50	12	35							
A250C65-10	65	18	60							
A250C75-10	75	25	85							
A250C80-10	80	25	85							
A250C100-10	100	45	150							
A250C110-10	110	60	190							
A250C125-10	125	75	240							
A250C135-10	135	115	395							
A250C150-10	150	130	460	40 kA @2000V RMS Sym	7.67 [194.8]	6.92 [175.8]	.75 [19.1]	1.42 [36.0]		
A200C165-10	165	150	350							
A200C175-10	175	165	440							
A200C200-10	200	225	500							
2.5 kV Max Type 30 external female to bolt (L bracket)					A	B	C	D	E	F
A250C25-30	25	3	9	50 kA @2500V RMS Sym	9.41 [239.0]	6.66 [169.2]	.75 [19.1]	1.10 [27.9]	8.79 [223.2]	1.25 [31.8]
A250C50-30	50	12	35							
A250C65-30	65	18	60							
A250C75-30	75	25	85							
A250C80-30	80	25	85							
A250C100-30	100	45	150							
A250C110-30	110	60	190							
A250C125-30	125	75	240							
2.5 kV Max Type 50 screw to bolt (L bracket)					A	B	C	D	E	F
A250C25-50	25	3	9	50 kA @2500V RMS Sym	9.11 [231.4]	6.74 [171.2]	.75 [19.1]	1.10 [27.9]	8.49 [215.6]	1.25 [31.8]
A250C50-50	50	12	35							
A250C65-50	65	18	60							
A250C75-50	75	25	85							
A250C80-50	80	25	85							
A250C100-50	100	45	150							
A250C110-50	110	60	190							
A250C125-50	125	75	240							
A250C135-50	135	115	395	40 kA @2000V RMS Sym	9.29 [236.0]	6.92 [175.8]	.75 [19.1]	1.42 [36.0]	8.67 [220.2]	1.25 [31.8]
A250C150-50	150	130	460							
A200C165-50	165	150	350							
A200C175-50	175	165	440							
A200C200-50	200	225	500							

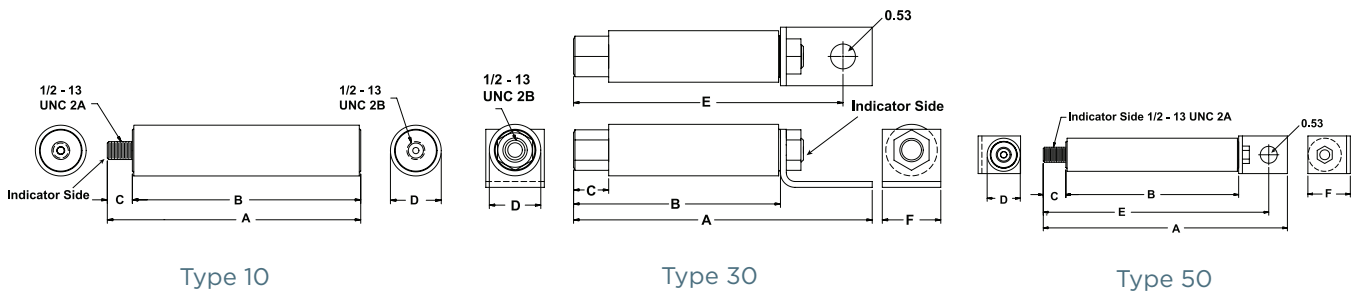

3.0kV CAPACITOR FUSES AMP-TRAP SERIES

Catalog Number	Ampere Rating	Melting I ² t (kA ² s)	Maximum 1 Clearing I ² t (kA ² s)	Maximum 1 Phase Interrupting Rating	Overall Length Inches (mm)	Tube Length Inches (mm)	Ind. Housing Inches (mm)	Body Dia Inches (mm)	Bracket Dimensions Inches (mm)	
3.0 kV Max Type 10 inner thread to screw					A	B	C	D	E	F
A300C50-10	50	12	35	50 kA @3000V RMS Sym	10.16 (258.1)	9.33 (237.0)	.75 (19.1)	1.10 (27.9)		
A300C60-10	60	18	65							
A300C75-10	75	26	80							
A300C95-10	95	45	140							
A300C100-10	100	45	140							
A300C115-10	115	60	200		10.16 (258.1)	9.33 (237.0)	.75 (19.1)	1.42 (36.0)		
A300C125-10	125	75	260							
A300C130-10	130	75	260							
A300C150-10	150	105	350							
A300C175-10	175	165	530							
3.0 kV Max Type 20 screw to bolt (flat bracket)					A	B	C	D	E	F
A300C50-20	50	12	35	50 kA @3000V RMS Sym	10.59 (269.1)	9.33 (237.0)	.75 (19.1)	1.10 (27.9)	3.00 (76.2)	1.25 (31.8)
A300C60-20	60	18	65							
A300C75-20	75	26	80							
A300C95-20	95	45	140							
A300C100-20	100	45	140							
A300C115-20	115	60	200		10.59 (269.0)	9.33 (237.0)	.75 (19.1)	1.42 (36.0)	3.00 (76.2)	1.25 (31.8)
A300C125-20	125	75	260							
A300C130-20	130	75	260							
A300C150-20	150	105	350							
A300C175-20	175	165	530							
3.0 kV Max Type 60 bolt (L bracket) to bolt (L bracket)					A	B	C	D	E	F
A300C50-60	50	12	35	50 kA @3000V RMS Sym						
A300C60-60	60	18	65							
A300C75-60	75	26	80							
A300C95-60	95	45	140							
A300C100-60	100	45	140							
A300C115-60	115	60	200		13.27 (337.1)	9.41 (239.0)	.47 (11.9)	1.42 (36.0)	12.02 (305.2)	1.25 (31.8)
A300C125-60	125	75	260							
A300C130-60	130	75	260							
A300C150-60	150	105	350							
A300C175-60	175	165	530							

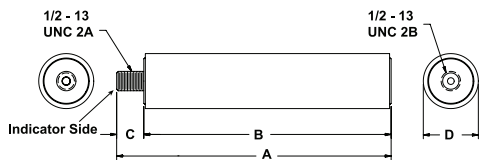

Type 10

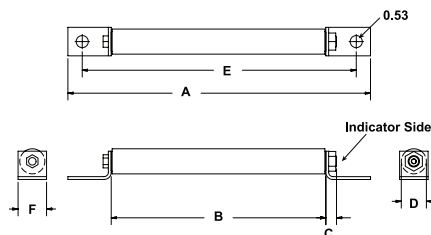

Type 60

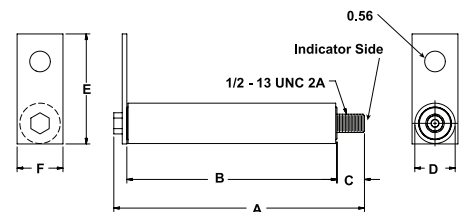

Type 20

MV

4.3kV CAPACITOR FUSES AMP-TRAP SERIES

Catalog Number	Ampere Rating	Melting I ² t (kA ² s)	Maximum 1 Clearing I ² t (kA ² s)	Maximum 1 Phase Interrupting Rating	Overall Length Inches (mm)	Tube Length Inches (mm)	Ind. Housing Inches (mm)	Body Dia Inches (mm)	Bracket Dimensions Inches (mm)	
4.3 kV Max Type 15 external female to bolt					A	B	C	D	E	F
A430C6-15	6	0.4	2.49	65 kA @4300V RMS Sym	9.50 (241.3)	7.12 (180.8)	.75 (19.1)	2.00 (50.8)	8.00 (203.2)	.75 (19.1)
A430C8-15	8	0.73	4.31							
A430C10-15	10	1.14	6.38							
A430C12-15	12	1.6	8.64							
A430C18-15	18	3	15							
A430C20-15	20	4.5	22.1							
A430C25-15	25	6.5	31.2							
A430C30-15	30	7.7	36.2							
A430C35-15	35	9	41.4							
A430C45-15	45	12	54.6							
A430C50-15	50	15	68							
A430C65-15	65	29	84							
A430C75-15	75	36	100							
A430C80-15	80	42	120							
A430C90-15	90	58	160							
A430C100-15	100	66	180							
4.3 kV Max Type 70 tube to tube					A	B	C	D	E	F
A430C6-70	6	0.4	2.49	65 kA @4300V RMS Sym	10.00 (254.0)	7.12 (180.8)	1.00 (25.4)	2.00 (50.8)	8.00 (203.2)	.63 (15.9)
A430C8-70	8	0.73	4.31							
A430C10-70	10	1.14	6.38							
A430C12-70	12	1.6	8.64							
A430C18-70	18	3	15							
A430C20-70	20	4.5	22.1							
A430C25-70	25	6.5	31.2							
A430C30-70	30	7.7	36.2							
A430C35-70	35	9	41.4							
A430C45-70	45	12	54.6							
A430C50-70	50	15	68							
A430C65-70	65	29	84							
A430C75-70	75	36	100							
A430C80-70	80	42	120							
A430C90-70	90	58	160							
A430C100-70	100	66	180							
4.35 kV Max Type 75 external female to tube					A	B	C	D	E	F
A430C6-75	6	0.4	2.49	65 kA @ 4300V RMS Sym	9.75 (247.7)	7.12 (180.8)	1.00 (2.54)	2.00 (50.8)	8.00 (203.2)	0.63 (15.9)
A430C8-75	8	0.73	4.31							
A430C10-75	10	1.14	6.38							
A430C12-75	12	1.6	8.64							
A430C18-75	18	3	15							
A430C20-75	20	4.5	22.1							
A430C25-75	25	6.5	31.2							
A430C30-75	30	7.7	36.2							
A430C35-75	35	9	41.4							
A430C45-75	45	12	54.6							
A430C50-75	50	15	68							
A430C65-75	65	29	84							
A430C75-75	75	36	100							
A430C80-75	80	42	120							
A430C90-75	90	58	160							
A430C100-75	100	66	180							

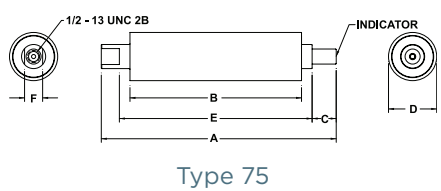
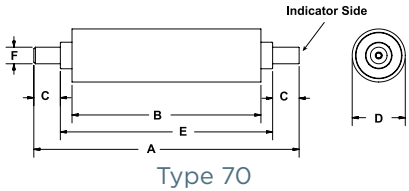
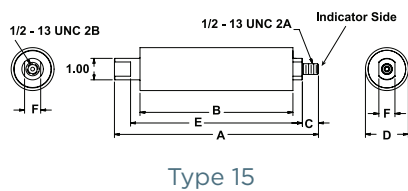

5.5kV CAPACITOR FUSES AMP-TRAP SERIES

Catalog Number	Ampere Rating	Melting I ² t (kA ² s)	Maximum 1 Clearing I ² t (kA ² s)	Maximum 1 Phase Interrupting Rating	Overall Length Inches (mm)	Tube Length Inches (mm)	Ind. Housing Inches (mm)	Body Dia Inches (mm)	Bracket Dimensions Inches (mm)	
5.5 kV Max Type 15 external female to bolt					A	B	C	D	E	F
A550C6-15	6	0.4	2.49	65 kA @ 5500V RMS Sym	9.50 (241.3)	7.12 (180.8)	.75 (19.1)	2.00 (50.8)	8.00 (203.2)	.75 (19.1)
A550C8-15	8	0.73	4.31							
A550C10-15	10	1.14	6.38							
A550C12-15	12	1.6	8.64							
A550C18-15	18	3	15							
A550C20-15	20	4.5	22.1							
A550C25-15	25	6.5	31.2							
A550C30-15	30	7.7	36.2							
A550C35-15	35	9	41.4	50 kA @ 5500V RMS Sym	9.50 (241.3)	.75 (19.1)	2.00 (50.8)	8.00 (203.2)	.75 (19.1)	
A550C40-15	40	12	54.6							
A550C50-15	50	15	68							
A550C65-15	65	35	156							
A550C75-15	75	43	186							
5.5 kV Max Type 70 tube to tube					A	B	C	D	E	F
A550C6-70	6	0.4	2.49	65 kA @ 5500V RMS Sym	10.00 (254.0)	7.12 (180.8)	1.00 (25.4)	2.00 (50.8)	8.00 (203.2)	.63 (15.9)
A550C8-70	8	0.73	4.31							
A550C10-70	10	1.14	6.38							
A550C12-70	12	1.6	8.64							
A550C18-70	18	3	15							
A550C20-70	20	4.5	22.1							
A550C25-70	25	6.5	31.2							
A550C30-70	30	7.7	36.2							
A550C35-70	35	9	41.4	50 kA @ 5500V RMS Sym	10.00 (254.0)	1.00 (25.4)	2.00 (50.8)	8.00 (203.2)	.63 (15.9)	
A550C40-70	40	12	54.6							
A550C50-70	50	15	68							
A550C65-70	65	35	156							
A550C75-70	75	43	186							

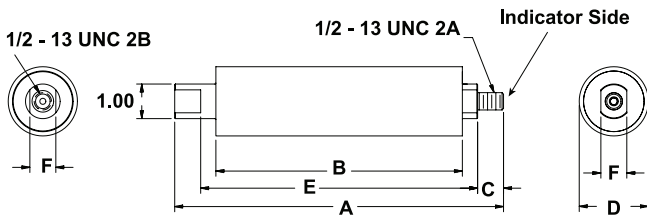

Type 15

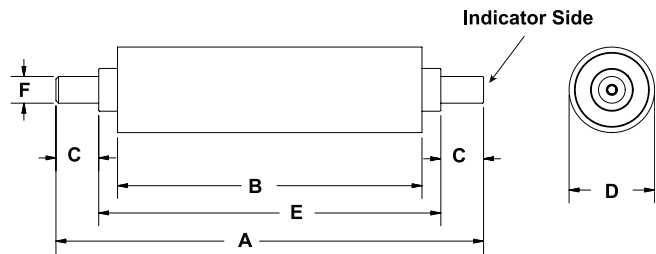

Type 70

M
V

5.5kV / 9.52kV CAPACITOR FUSES AMP-TRAP SERIES

5.5kV Capacitor Fuses - Amp-Trap Series

Catalog Number	Ampere Rating	Melting I ² t [kA ² s]	Maximum Clearing I ² t [kA ² s]	Maximum 1 Phase Interrupting Rating (kA)	Overall Length Inches (mm)	Tube Length Inches (mm)	Indicator Housing Inches (mm)	Body Dia Inches (mm)	Inches (mm)	Inches (mm)
5.5 kV Max Type 75 external female to tube					A	B	C	D	E	F
A550C6-75	6	0.4	2.49	65 kA @ 5500V RMS Sym	9.75 (247.7)	7.12 (180.8)	1.00 (2.54)	2.00 (50.8)	8.00 (203.2)	0.63 (15.9)
A550C8-75	8	0.73	4.31							
A550C10-75	10	1.14	6.38							
A550C12-75	12	1.6	8.64							
A550C18-75	18	3	15							
A550C20-75	20	4.5	22.1							
A550C25-75	25	6.5	31.2							
A550C30-75	30	7.7	36.2							
A550C35-75	35	9	41.4							
A550C40-75	40	12	54.6	50 kA @ 5500V RMS Sym	9.75 (247.7)	7.12 (180.8)	1.00 (2.54)	2.00 (50.8)	8.00 (203.2)	0.63 (15.9)
A550C50-75	50	15	68							
A550C65-75	65	35	156							
A550C75-75	75	43	186							

Type 75

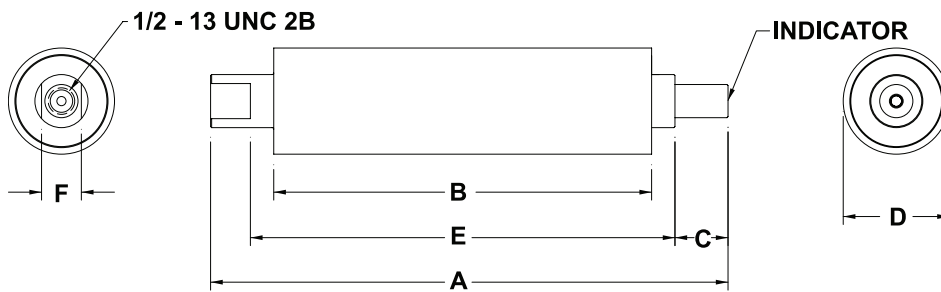

5.5kV Capacitor fuses - 9F60 series, EJO-5

12" (305 mm) Clip Centers clip-in mounting* - Suitable for use indoors or outdoors



Catalog No.	Amp Rating	No. of Barrels	Indicating	Diameter Inches (mm)	Length Inches (mm)	Max Voltage	Max IR RMS Sym
9F60RJD025	25A	1	Yes	2.08 (20.8)	14.0 (356)	5.5 kV	50kA
9F60RJD040	40A						
9F60RJD080	80A						

9.52kV Capacitor fuses - 9F60 series, EJO-5

12" (305 mm) Clip Centers clip-in mounting* - Suitable for use indoors or outdoors



Catalog No.	Amp Rating	No. of Barrels	Indicating	Diameter Inches (mm)	Length Inches (mm)	Max Voltage	Max IR RMS Sym
9F60RJF015	15A	1	Yes	2.08 (20.8)	14.0 (356)	9.25 kV	50kA
9F60RJF025	25A						
9F60RJF040	40A						

*EJO-5 Capacitor fuses are typically mounted directly on the capacitor.





Your problem: Parallel cables from your main transformer. The welding station down in the machine shop. Need a fuse designed specifically to protect your solar power installation? Applications as varied and specialized as telecommunications systems, forklifts, and DC-powered equipment . . . If your plant is like most, it's full of highly specialized circuit protecting applications. Still, as specialized as the installations sometimes are, they have in common the need for a high performance, failsafe solution.

Our solution: No matter how specialized your application is, Mersen brings its broad expertise and numerous resources to bear on it. The result is a line of Special Purpose Fuses that unflinchingly perform to application-specific requirements. Whether you're specifying our Helio Protection fuses, Cable Protectors, Welder Protectors, and Telecommunications fuses — or replacing our Form 600 fuses, or Forklift Truck fuses.

Want more information fast? For more technical or application-specific information, please call our special purpose products experts at 978-465-4853 or visit our website at ep.mersen.com.

Special Purpose

A WORLD OF
CIRCUIT PROTECTION
UNDER ONE ROOF

EV/Automotive

- M-fuse Battery Module Fuses SP 2
- MEV55 Battery Pack Fuses . . SP 5
- MEV70 Battery Pack Fuses . . SP 9
- MEV100 Battery Pack Fuses SP 12
- Hybrid Xp SeriesSP 15
- Hybrid Xs-EV SeriesSP 17
- Automotive Fuses & HoldersSP 21
- Forklift Truck Fuses. SP 24

Cable Protectors

- CP 600V Cable Protectors . SP 26
- 2CL 250V Cable Protectors SP 34

DC Protection

- A60C Capacitor Fuses SP 35
- A4BX Welder Protectors . . . SP 36
- A2Y & A6Y Form 600 Fuses SP 37

Photovoltaic (PV)

- HP6M PV Fuses SP 39
- HP10M PV Fuses SP 41
- Dual HP10M Fuses SP 43
- HP15M PV Fuses SP 44
- Dual HP15M Fuses SP 46
- HP15G PV Fuses. SP 47
- HP6J PV Fuses. SP 49
- HP10J PV Fuses. SP 51
- HP10NH PV Fuses SP 55
- HP12NH PV Fuses SP 57
- HP15NH PV Fuses SP 59



m-fuse MF 100VDC Max.

L/R \leq 1.5ms, 50 - 200A

SPECIAL PURPOSE

BATTERY MODULE FUSES



m-fuse line-up belongs to the new DC Over-Current protection (O.C.P.) range developed by Mersen to address specific needs in EV/HEV and Battery Electrical Storage System.

m-fuse provides the ultimate protection of the battery modules offering reliable clearing of DC fault currents.

It has been specifically engineered and tested to provide DC applications best-in-class protection performance: Up to 100VDC, Current rating (I_n) = 50 to 200A, Interrupting Rating (IR) = 20kA, L/R \leq 1.5ms, Minimum Breaking Capacity (MBC) < 1kA.

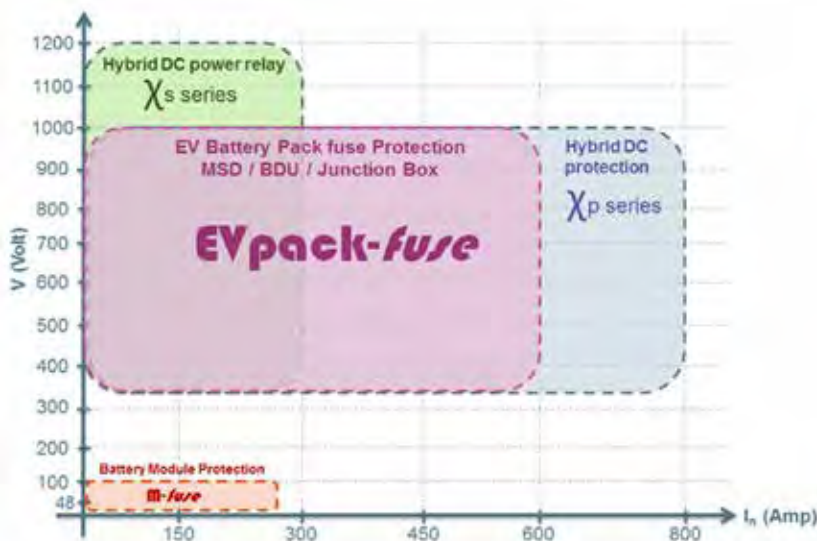

FEATURES/BENEFITS:

- Design for DC applications
- Low watt losses
- High cycling performance
- Full coverage of battery module voltage and current
- Ultra compact size
- Current Ratings (I_n): 50 to 200A
- Interrupting Rating: 20kA @ 100VDC, L/R < 1.5ms

APPLICATIONS:

- Battery modules protection
- EV/HEV
- Electrical Energy Storage
- Supercapacitor module protection

STANDARDS:

- Power Cycling & Vibrations: JASO D622
- IATF - ISO/TS 16949 Quality management undergoing certification



m-fuse

PRODUCT RANGE



MF100A-4

MF-A Round Body Fuse

Catalog number	Rated DC voltage	Rated current I _n	Power dissipation at 0.5 I _n	Min. breaking capacity (MBC)	Max. time to clear MBC	Weight
MF50A-4	100 V	50 A	0.8 W	180 A	50 ms	68 g
MF60A-4	100 V	60 A	0.9 W	210 A	50 ms	68 g
MF70A-4	100 V	70 A	1.1 W	250 A	50 ms	68 g
MF80A-4	100 V	80 A	1.6 W	280 A	50 ms	68 g
MF90A-4	100 V	90 A	1.8 W	320 A	50 ms	68 g
MF100A-4	100 V	100 A	2 W	360 A	50 ms	68 g
MF125A-4	100 V	125 A	2.6 W	450 A	50 ms	68 g
MF150A-4	100 V	150 A	3.2 W	540 A	50 ms	68 g
MF175A-4	100 V	175 A	4 W	630 A	50 ms	68 g
MF200A-4	100 V	200 A	4.4 W	720 A	50 ms	68 g



MF50B-4

MF-B Cylindrical Body Fuse

Catalog number	Rated DC voltage	Rated current I _n	Power dissipation at 0.5 I _n	Min. breaking capacity (MBC)	Max. time to clear MBC	Weight
MF50B-4	100 V	50 A	1.8 W	140 A	10 s	28 g
MF60B-4	100 V	60 A	2.1 W	170 A	10 s	28 g
MF75B-4	100 V	75 A	2.7 W	210 A	10 s	28 g
MF80B-4	100 V	80 A	2.7 W	225 A	10 s	28 g
MF100B-4	100 V	100 A	2.3 W	280 A	10 s	28 g
MF125B-4	100 V	125 A	2.5 W	350 A	10 s	28 g
MF150B-4	100 V	150 A	2.7 W	420 A	10 s	28 g
MF160B-4	100 V	160 A	3.1 W	450 A	10 s	28 g
MF180B-4	100 V	180 A	3.4 W	500 A	10 s	28 g

DIMENSIONS

MFA -4 (50-200A)

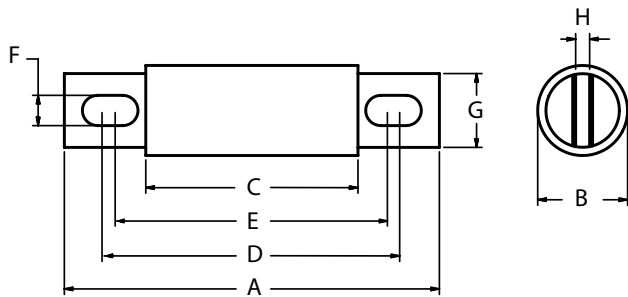

MF50A-4 to MF200A-4 (inch. / mm)	2,66 67,6	1 25,4	1,16 29,5	2,19 55,6	1,88 47,6	0,31 7,9	0,74 18,8	0,13 3,3
----------------------------------	--------------	-----------	--------------	--------------	--------------	-------------	--------------	-------------

MF8 -4 (50-180A)

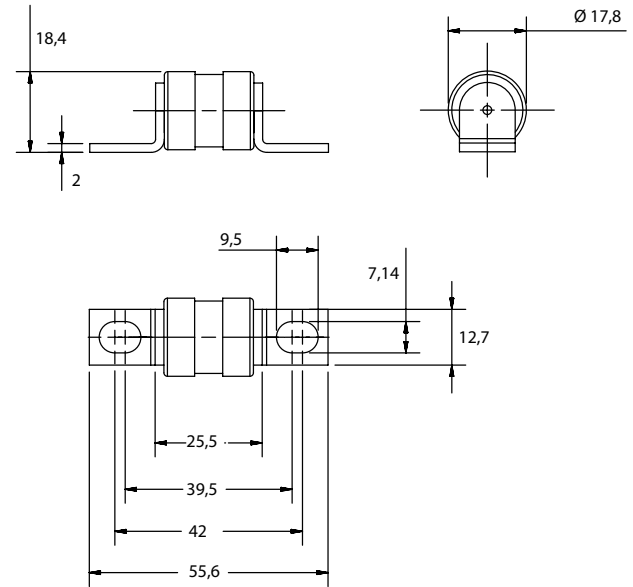

Dimensions in mm

ACCESSORIES



1SC250



1SC375

Fuse blocks

Catalog number	Item number	Rated DC voltage	Application DC Fuses	Contact Materials	Weight
P243 Fuse blocks					
P243D	P243D	1000 V	MF-A fuses from 70 to 450A	Tin-Plated Copper	0.12 kg
1SC/1MSC Modular Fuse blocks					
1SCM8	1SCM8	1000 V	MF-A, MEV70A, MEV100A fuses up to 400A	Zinc-Plated Steel	68 g
1SC250	1SC250	1000 V	MF-A, MEV70A, MEV100A fuses up to 400A	Zinc-Plated Steel	68 g
1SC375	1SC375	1000 V	MF-A, MEV70A, MEV100A fuses up to 800A	Zinc-Plated Steel	68 g
1SCM10	1SCM10	1000 V	MF-A, MEV70A, MEV100A fuses up to 800A	Zinc-Plated Steel	68 g

EVpack-fuse MEV55

550 VDC Max., L/R \leq 1ms, 5 - 50A

SPECIAL PURPOSE

BATTERY PACK FUSES



EVpack-fuse line-up belongs to the new DC Over-Current protection (O.C.P.) range developed by Mersen to address specific needs in EV/HEV and Battery Electrical Storage System.

EVpack-fuse provides the ultimate protection of the battery pack offering reliable clearing of DC fault currents.

It has been specifically engineered and tested to provide DC applications best-in-class protection performance: Up to 550VDC, Current rating (I_n)= 5 to 50A, Interrupting Rating (IR) = 20kA, L/R \leq 1ms, Minimum Breaking Capacity (MBC) < 3kA for a perfect matching with DC contactor.

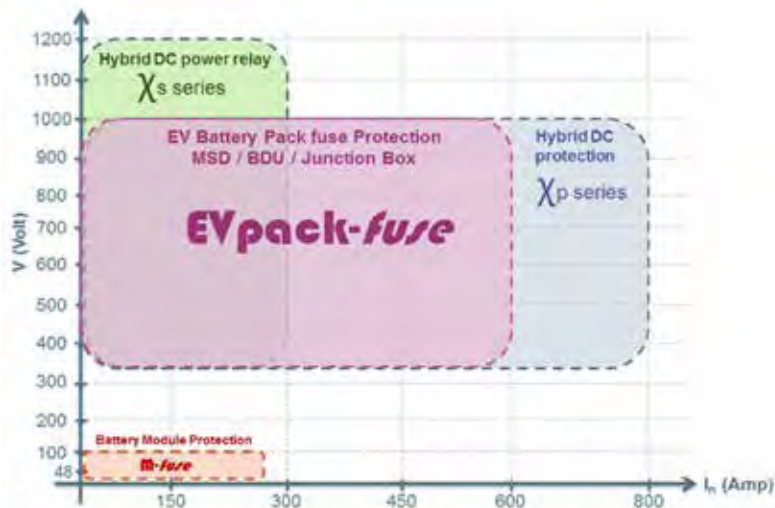

FEATURES/BENEFITS:

- Design for DC applications
- Low watt losses
- High cycling performance
- Full coverage of battery module voltage and current
- Ultra compact size
- Current Ratings (I_n): 5 to 50A
- Interrupting Rating (IR): 20kA @ 550VDC, L/R < 1ms

SP

APPLICATIONS:

- EV/HEV
- Electrical Energy Storage
- Battery pack protection
- Battery Disconnect Unit (BDU)
- Battery Junction Box for auxiliaries
- Battery charger
- Supercapacitor pack protection
- Backup protection for DC relay/disconnector / switch
- Maintenance Safety Disconnect (MSD)

STANDARDS:

- Power Cycling & Vibration: JASO D622
- IATF - ISO/TS 16949 Quality management undergoing certification



PRODUCT RANGE



MEV55C30

MEV55C Ferrule Fuse

Catalog number	Rated DC voltage	Rated current I _n	Power dissipation at 0.5 I _n	Min. breaking capacity (MBC)	Max. time to clear MBC	Weight
MEV55C5	550 V	5 A	0.25 W	10 A	10 s	7.5 g
MEV55C6	550 V	6 A	0.29 W	12 A	10 s	7.5 g
MEV55C7	550 V	7 A	0.31 W	14 A	10 s	7.5 g
MEV55C8	550 V	8 A	0.4 W	16 A	10 s	7.5 g
MEV55C10	550 V	10 A	0.45 W	20 A	10 s	7.5 g
MEV55C12	550 V	12 A	0.47 W	24 A	10 s	7.5 g
MEV55C15	550 V	15 A	0.49 W	30 A	100 s	7.5 g
MEV55C20	550 V	20 A	0.56 W	40 A	100 s	7.5 g
MEV55C25	550 V	25 A	0.63 W	50 A	100 s	7.5 g
MEV55C30	550 V	30 A	0.68 W	60 A	100 s	7.5 g
MEV55C30/40	550 V	40 A	0.63 W	150 A	10 s	7.5 g
MEV55C30/50	550 V	50 A	1 W	180 A	10 s	7.5 g



MEV55C15-S

MEV55C -S Surface Mount Fuse

Catalog number	Rated DC voltage	Rated current I _n	Power dissipation at 0.5 I _n	Min. breaking capacity (MBC)	Max. time to clear MBC	Weight
MEV55C5-S	550 V	5 A	0.25 W	10 A	10 s	9.9 g
MEV55C6-S	550 V	6 A	0.29 W	12 A	10 s	9.9 g
MEV55C7-S	550 V	7 A	0.31 W	14 A	10 s	9.9 g
MEV55C8-S	550 V	8 A	0.4 W	16 A	10 s	9.9 g
MEV55C10-S	550 V	10 A	0.45 W	20 A	10 s	9.9 g
MEV55C12-S	550 V	12 A	0.47 W	24 A	10 s	9.9 g
MEV55C15-S	550 V	15 A	0.49 W	30 A	100 s	9.9 g
MEV55C20-S	550 V	20 A	0.56 W	40 A	100 s	9.9 g
MEV55C25-S	550 V	25 A	0.63 W	50 A	100 s	9.9 g
MEV55C30-S	550 V	30 A	0.68 W	60 A	100 s	9.9 g
MEV55C30/40-S	550 V	40 A	0.63 W	150 A	10 s	9.9 g
MEV55C30/50-S	550 V	50 A	1 W	180 A	10 s	9.9 g



MEV55C30-P

MEV55C -P PC Board Mount

Catalog number	Rated DC voltage	Rated current I _n	Power dissipation at 0.5 I _n	Min. breaking capacity (MBC)	Max. time to clear MBC	Weight
MEV55C5-P	550 V	5 A	0.25 W	10 A	10 s	9.9 g
MEV55C6-P	550 V	6 A	0.29 W	12 A	10 s	9.9 g
MEV55C7-P	550 V	7 A	0.31 W	14 A	10 s	9.9 g
MEV55C8-P	550 V	8 A	0.4 W	16 A	10 s	9.9 g
MEV55C10-P	550 V	10 A	0.45 W	20 A	10 s	9.9 g
MEV55C12-P	550 V	12 A	0.5 W	24 A	10 s	9.9 g
MEV55C15-P	550 V	15 A	0.45 W	30 A	100 s	9.9 g
MEV55C20-P	550 V	20 A	0.54 W	40 A	100 s	9.9 g
MEV55C25-P	550 V	25 A	0.59 W	50 A	100 s	9.9 g
MEV55C30-P	550 V	30 A	0.65 W	60 A	100 s	9.9 g
MEV55C30/40-P	550 V	40 A	0.63 W	150 A	10 s	9.9 g
MEV55C30/50-P	550 V	50 A	1.1 W	180 A	10 s	9.9 g

SP

DIMENSIONS

MEV55C Ferrule Fuse (5-50A)

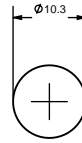
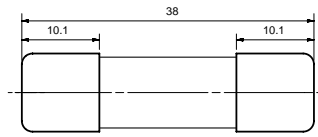

Dimensions in mm

MEV55C -S Surface Mount Fuse (5-50A)

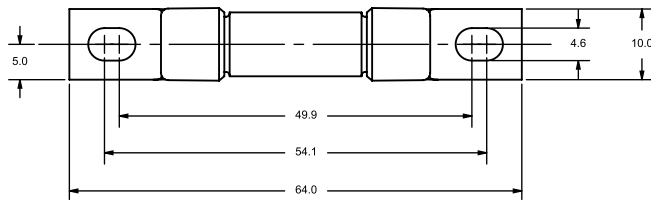
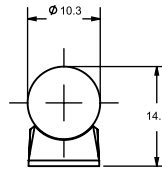
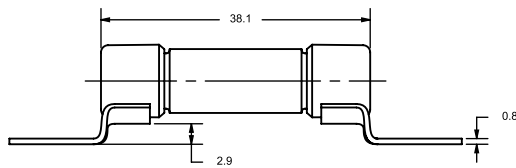

Dimensions in mm

MEV55C -P PC Board Mount (5-50A)

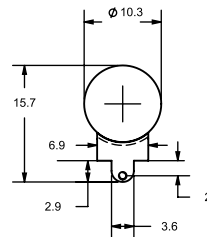
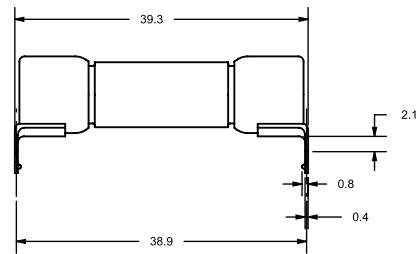

Dimensions in mm

SP

ACCESSORIES

Fuse blocks



30311



30312



30313



30321



30322



30323

Catalog number	Item number	Rated DC voltage	Application DC Fuses	Number of poles/phases	Contact Materials	Wire Range	Weight
Open-style fuse blocks							
Screw w/ double quick connects at both ends							
30310	30310	600 V	MEV55C fuses up to 30A	Adder	Tin-plated Copper	Cu #10-14	42 g
30311	30311	600 V	MEV55C fuses up to 30A	1	Tin-plated Copper	Cu #10-14	47 g
30312	30312	600 V	MEV55C fuses up to 30A	2	Tin-plated Copper	Cu #10-14	80 g
30313	30313	600 V	MEV55C fuses up to 30A	3	Tin-plated Copper	Cu #10-14	0.12 kg
Pressure plate (sems) w/ double quick connects at both ends							
30320	30320	600 V	MEV55C fuses up to 30A	Adder	Tin-plated Copper	Cu #10-14	-
30321	30321	600 V	MEV55C fuses up to 30A	1	Tin-plated Copper	Cu #10-14	96 g
30322	30322	600 V	MEV55C fuses up to 30A	2	Tin-plated Copper	Cu #10-14	93 g
30323	30323	600 V	MEV55C fuses up to 30A	3	Tin-plated Copper	Cu #10-14	0.13 kg
Copper box							
30350	30350	600 V	MEV55C fuses up to 30A	Adder	Tin-plated Copper	Cu #6-14	-
30351	30351	600 V	MEV55C fuses up to 30A	1	Tin-plated Copper	Cu #6-14	49 g
30352	30352	600 V	MEV55C fuses up to 30A	2	Tin-plated Copper	Cu #6-14	-
30353	30353	600 V	MEV55C fuses up to 30A	3	Tin-plated Copper	Cu #6-14	0.13 kg

SP

EVpack-fuse MEV70

700 VDC Max., L/R \leq 1ms, 35 - 600A

SPECIAL PURPOSE

BATTERY PACK FUSES



EVpack-fuse line-up belongs to the new DC Over-Current protection (O.C.P.) range developed by Mersen to address specific needs in EV/HEV and Battery Electrical Storage System

EVpack-fuse provides the ultimate protection of the battery pack offering reliable clearing of DC fault currents.

It has been specifically engineered and tested to provide DC applications best-in-class protection performance: Up to 700VDC, Current rating (I_n)= 35 to 600A, Interrupting Rating (IR) = 20kA, L/R \leq 1ms, Minimum Breaking Capacity (MBC) < 3kA for a perfect matching with DC contactor in addition to withstanding high inrush current auxiliary applications (e.g. air conditioning...) with MEV70V.

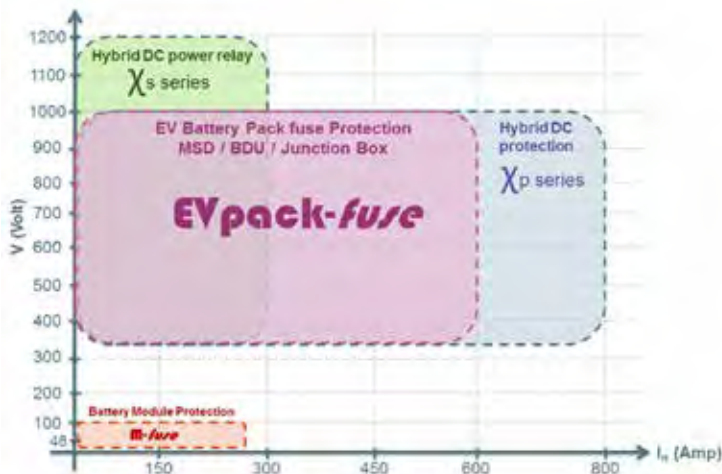

FEATURES/BENEFITS:

- Design for DC applications
- Low watt losses
- High cycling performance
- Full coverage of battery module voltage and current
- Ultra compact size
- Current Ratings (I_n): 35 to 600A
- Interrupting Rating (IR): 20kA @ 700VDC, L/R \leq 1ms
- High inrush current capability

SP

APPLICATIONS:

- EV/HEV
- Electrical Energy Storage
- Battery pack protection
- Battery Disconnect Unit (BDU)
- Battery Junction Box for auxiliaries
- Battery charger
- Supercapacitor pack protection
- Backup protection for DC relay / disconnecter / switch
- Maintenance Safety Disconnect (MSD)

STANDARDS:

- Power Cycling & Vibration: JASO D622
- IATF - ISO/TS 16949 Quality management undergoing certification



PRODUCT RANGE



MEV70V100-S

MEV70V -S Surface Mount Fuse

Catalog number	Rated DC voltage	Rated current I _n	Power dissipation at 0.5 I _n	Min. breaking capacity (MBC)	Max. time to clear MBC	Weight
MEV70V35-S	700 V	35 A	0.86 W	125 A	5 s	9.9 g
MEV70V40-S	700 V	40 A	0.82 W	150 A	5 s	9.9 g
MEV70V50-S	700 V	50 A	1.2 W	175 A	5 s	9.9 g
MEV70V60-S	700 V	60 A	1.47 W	200 A	5 s	9.9 g
MEV70V70-S	700 V	70 A	1.89 W	200 A	30 s	59 g
MEV70V80-S	700 V	80 A	1.75 W	270 A	30 s	59 g
MEV70V100-S	700 V	100 A	2 W	330 A	30 s	59 g
MEV70V125-S	700 V	125 A	2.74 W	1500 A	150 ms	59 g
MEV70V150-S	700 V	150 A	3.54 W	1500 A	200 ms	59 g
MEV70V160-S	700 V	160 A	3.75 W	1500 A	300 ms	59 g
MEV70V175-S	700 V	175 A	4.63 W	1500 A	420 ms	59 g



MEV70A600-4

MEV70A Round Body Fuse

Catalog number	Rated DC voltage	Rated current I _n	Power dissipation at 0.5 I _n	Min. breaking capacity (MBC)	Max. time to clear MBC	Weight
MEV70A50-4	700 V	50 A	1.4 W	380 A	50 ms	99 g
MEV70A60-4	700 V	60 A	1.8 W	460 A	50 ms	99 g
MEV70A70-4	700 V	70 A	2.2 W	540 A	50 ms	99 g
MEV70A80-4	700 V	80 A	2.5 W	610 A	50 ms	99 g
MEV70A90-4	700 V	90 A	2.7 W	690 A	50 ms	99 g
MEV70A100-4	700 V	100 A	3.1 W	760 A	50 ms	99 g
MEV70A125-4	700 V	125 A	3.8 W	870 A	60 ms	0.17 kg
MEV70A150-4	700 V	150 A	4.5 W	1040 A	60 ms	0.17 kg
MEV70A175-4	700 V	175 A	5.2 W	1210 A	60 ms	0.17 kg
MEV70A200-4	700 V	200 A	5.9 W	1380 A	60 ms	0.17 kg
MEV70A225-4	700 V	225 A	6.7 W	1190 A	140 ms	0.26 kg
MEV70A250-4	700 V	250 A	7.4 W	1320 A	140 ms	0.26 kg
MEV70A300-4	700 V	300 A	8.8 W	1580 A	140 ms	0.26 kg
MEV70A350-4	700 V	350 A	10.2 W	1840 A	140 ms	0.26 kg
MEV70A400-4	700 V	400 A	11.7 W	2100 A	140 ms	0.26 kg
MEV70A450-4	700 V	450 A	12.4 W	2200 A	360 ms	0.52 kg
MEV70A500-4	700 V	500 A	13.9 W	2460 A	360 ms	0.52 kg
MEV70A600-4	700 V	600 A	16.6 W	2950 A	360 ms	0.52 kg

DIMENSIONS

MEV70V -S (35-60A)

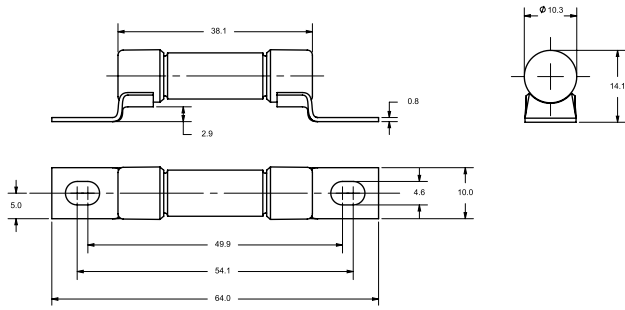

Dimensions in mm

MEV70V -S (70-175A)

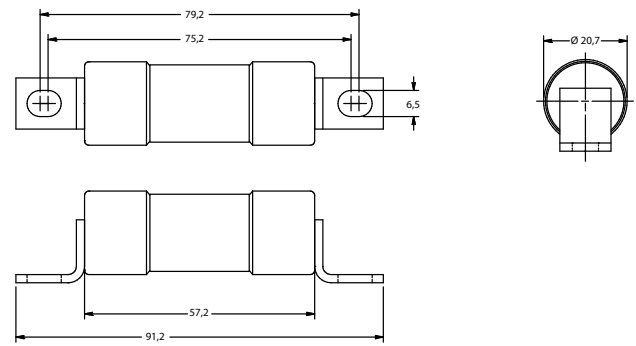

Dimensions in mm

MEV70A -4 (50-600A)

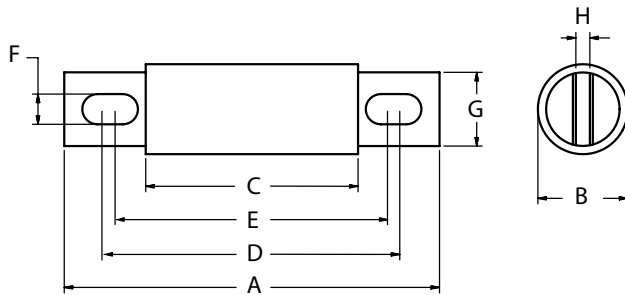

Article Number	A	B	C	D	E	F	G	H
MEV70A50 to 100 (inch. / mm)	3.63 92.2	1 25.4	2.13 54.1	2.94 74.7	2.75 69.8	0.31 7.9	0.50 19	0.13 3.2
MEV70A125 to 200 (inch. / mm)	3.63 92.2	1.22 31	2.13 54.1	2.94 74.7	2.81 71.4	0.31 7.9	1 25.4	0.19 4.8
MEV70A225 to 400 (inch. / mm)	4.34 110	1.50 38.1	2.09 53.1	3.41 86.6	2.78 70.6	0.41 10.4	1 25.4	0.25 6.4
MEV70A450 to 600 (inch. / mm)	4.47 114	2 50.8	2.22 56.4	3.53 89.7	2.91 73.9	0.41 10.4	1.5 38.1	0.25 6.4

ACCESSORIES

Fuse blocks



ISC250



ISC375

Catalog number	Item number	Rated DC voltage	Application DC Fuses	Contact Materials	Weight
P243 Fuse blocks					
P243E	P243E	700 V	MEV70A fuses from 50 to 200A	Tin-Plated Copper	0.12 kg
P266 Fuse blocks					
P266C	P266C	1000 V	MEV70A fuses from 225 to 600A	Stainless Steel	0.40 kg
1SC/1MSC Modular Fuse blocks					
1SCM8	1SCM8	1000 V	MF-A, MEV70A, MEV100A fuses up to 400A	Zinc-Plated Steel	68 g
1SC250	1SC250	1000 V	MF-A, MEV70A, MEV100A fuses up to 400A	Zinc-Plated Steel	68 g
1SC375	1SC375	1000 V	MF-A, MEV70A, MEV100A fuses up to 800A	Zinc-Plated Steel	68 g
1SCM10	1SCM10	1000 V	MF-A, MEV70A, MEV100A fuses up to 800A	Zinc-Plated Steel	68 g

SP

EVpack-fuse MEV100

1,000 VDC Max., L/R ≤ 1ms, 8 - 600A

SPECIAL PURPOSE

BATTERY PACK FUSES

SP



EVpack-fuse line-up belongs to the new DC Over-Current protection (O.C.P.) range developed by Mersen to address specific needs in EV/HEV and Battery Electrical Storage System

EVpack-fuse provides the ultimate protection of the battery pack offering reliable clearing of DC fault currents.

It has been specifically engineered and tested to provide DC applications best-in-class protection performance: Up to 1,000VDC, Current rating (In)= 8 to 600A, Interrupting Rating (IR) = 20kA, L/R ≤ 1ms, Minimum Breaking Capacity (MBC) < 3kA for a perfect matching with DC contactor.

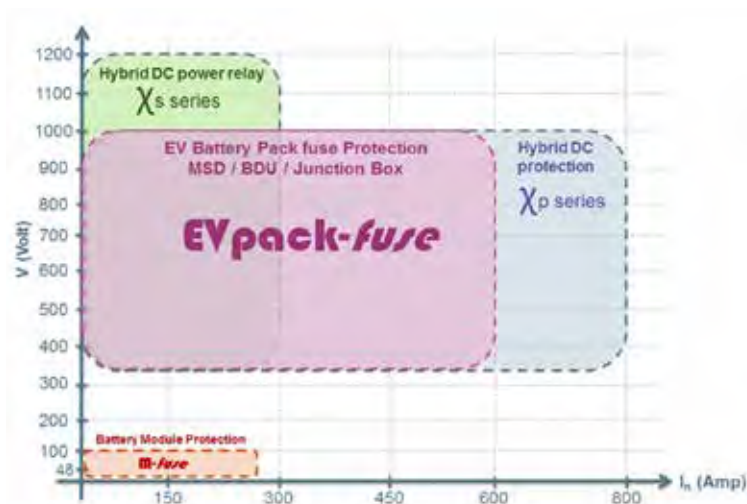

FEATURES/BENEFITS:

- Design for DC applications
- Low watt losses
- High cycling performance
- Full coverage of battery module voltage and current
- Ultra compact size
- Current Ratings (In): 8 to 600A
- Interrupting Rating (IR): 20kA @ 1,000 VDC, L/R ≤ 1ms

APPLICATIONS:

- EV/HEV
- Electrical Energy Storage
- Battery pack protection
- Battery Disconnect Unit (BDU)
- Battery Junction Box for auxiliaries
- Battery charger
- Supercapacitor pack protection
- Backup protection for DC relay / disconnecter / switch
- Maintenance Safety Disconnect (MSD)

STANDARDS:

- Power Cycling & Vibration: JASO D622
- IATF - ISO/TS 16949 Quality management undergoing certification



PRODUCT RANGE



MEV100C30

MEV100C Ferrule Fuse

Catalog number	Rated DC voltage	Rated current I _n	Power dissipation at 0.5 I _n	Min. breaking capacity (MBC)	Max. time to clear MBC	Weight
MEV100C8	1000 V	8 A	0.23 W	16 A	100 s	7.5 g
MEV100C10	1000 V	10 A	0.32 W	20 A	100 s	7.5 g
MEV100C12	1000 V	12 A	0.42 W	24 A	100 s	7.5 g
MEV100C15	1000 V	15 A	0.63 W	30 A	100 s	7.5 g
MEV100C20	1000 V	20 A	0.92 W	40 A	100 s	7.5 g
MEV100C25	1000 V	25 A	1.1 W	50 A	100 s	7.5 g
MEV100C30	1000 V	30 A	1.2 W	60 A	100 s	7.5 g



MEV100C15-S

MEV100C -S Surface Mount

Catalog number	Rated DC voltage	Rated current I _n	Power dissipation at 0.5 I _n	Min. breaking capacity (MBC)	Max. time to clear MBC	Weight
MEV100C8-S	1000 V	8 A	0.23 W	16 A	100 s	9.9 g
MEV100C10-S	1000 V	10 A	0.32 W	20 A	100 s	9.9 g
MEV100C12-S	1000 V	12 A	0.42 W	24 A	100 s	9.9 g
MEV100C15-S	1000 V	15 A	0.63 W	30 A	100 s	9.9 g
MEV100C20-S	1000 V	20 A	0.92 W	40 A	100 s	9.9 g
MEV100C25-S	1000 V	25 A	1.1 W	50 A	100 s	9.9 g
MEV100C30-S	1000 V	30 A	1.2 W	60 A	100 s	9.9 g



MEV100A300-4

MEV100A Round Body Fuse

Catalog number	Rated DC voltage	Rated current I _n	Power dissipation at 0.5 I _n	Min. breaking capacity (MBC)	Max. time to clear MBC	Weight
MEV100A50-4 or -4Y*	1000 V	50 A	1.8 W	960 A	40 ms	0.12 kg
MEV100A60-4 or -4Y*	1000 V	60 A	2.2 W	1160 A	40 ms	0.12 kg
MEV100A70-4 or -4Y*	1000 V	70 A	2.7 W	1350 A	40 ms	0.12 kg
MEV100A80-4 or -4Y*	1000 V	80 A	3.2 W	1540 A	40 ms	0.12 kg
MEV100A90-4 or -4Y*	1000 V	90 A	3.6 W	1730 A	40 ms	0.12 kg
MEV100A100-4 or -4Y*	1000 V	100 A	4.3 W	1920 A	40 ms	0.12 kg
MEV100A125-4 or -4Y*	1000 V	125 A	4 W	940 A	80 ms	0.19 kg
MEV100A150-4 or -4Y*	1000 V	150 A	5.2 W	1130 A	80 ms	0.19 kg
MEV100A175-4 or -4Y*	1000 V	175 A	6.3 W	1320 A	80 ms	0.19 kg
MEV100A200-4 or -4Y*	1000 V	200 A	7.4 W	1510 A	80 ms	0.19 kg
MEV100A225-4	1000 V	225 A	6.7 W	2200 A	80 ms	0.30 kg
MEV100A250-4	1000 V	250 A	7.6 W	2430 A	80 ms	0.30 kg
MEV100A300-4	1000 V	300 A	9.5 W	2920 A	80 ms	0.30 kg

*Catalog numbers ending with "-4Y" are designated for metric screws



MEV100J400-4

MEV100J Round Body Fuse

Catalog number	Rated DC voltage	Rated current I _n	Power dissipation at 0.5 I _n	Min. breaking capacity (MBC)	Max. time to clear MBC	Weight
MEV100J350-4	1000 V	350 A	9 W	700 A	180 s	0.86 kg
MEV100J400-4	1000 V	400 A	10.4 W	800 A	180 s	0.86 kg
MEV100J450-4	1000 V	450 A	11.2 W	900 A	235 s	1.34 kg
MEV100J500-4	1000 V	500 A	11.6 W	1000 A	280 s	1.34 kg
MEV100J600-4	1000 V	600 A	16.4 W	1200 A	200 s	1.34 kg

SP

DIMENSIONS

MEV100C Ferrule Fuse (8-30A)

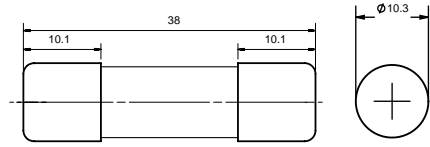

Dimensions in mm

MEV100C -S Surface Mount Fuse (8-30A)

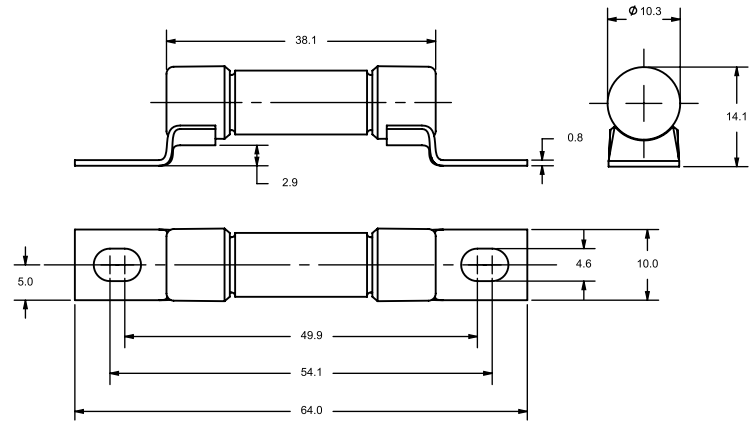

Dimensions in mm

MEV100A (50-300A) & MEV100J (350-600A)

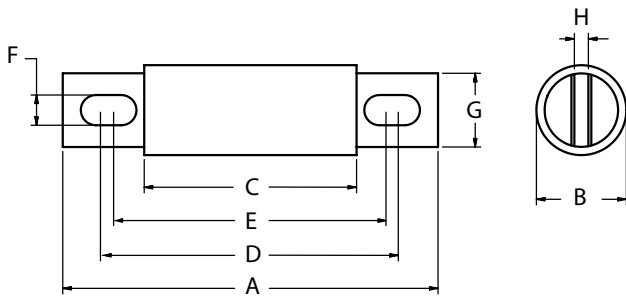

Article Number	A	B	C	D	E	F	F*	G	H
MEV100A50 to 100 [inch. / mm]	4.38 111	1 25.4	2.88 73	3.69 93.6	3.50 88.9	0.31 7.9	0.35 9.0	0.75 19	0.13 3.2
MEV100A125 to 200 [inch. / mm]	4.38 111	1.22 31	2.88 73	3.69 93.6	3.56 90.5	0.31 7.9	0.35 9.0	1 25.4	0.19 4.8
MEV100A225 to 300 [inch. / mm]	5.09 129	1.50 38.1	2.84 72.2	4.16 106	3.53 89.7	0.40 10.2	-	1 25.4	0.25 6.4
MEV100J350 to 400 [inch. / mm]	7.13 181	2.13 54	3.38 85.9	5.81 137.2	5.25 129.5	0.41 10.4	-	1.63 41.4	0.25 6.4
MEV100J450 to 600 [inch. / mm]	8 203.2	2.50 63.5	3.75 95.3	6.19 157.2	5.81 147.6	0.53 13.5	-	2.50 6.3	0.38 9.7

*Catalog numbers ending with "-4Y" are designated for metric screws

ACCESSORIES

Fuse blocks



Catalog number	Item number	Rated DC voltage	Application DC Fuses	Contact Materials	Weight
P243 Fuse blocks					
P243C	P243C	700 V	MEV70A fuses from 225 to 600A	Tin-Plated Copper	0.12 kg
P266 Fuse blocks					
P266A	P266A	1000 V	MEV100A fuses from 225 to 600A	Stainless Steel	0.39 kg
1SC/1MSC Modular Fuse blocks					
1SCM8	1SCM8	1000 V	MF-A, MEV70A, MEV100A fuses up to 400A	Zinc-Plated Steel	68 g
1SC250	1SC250	1000 V	MF-A, MEV70A, MEV100A fuses up to 400A	Zinc-Plated Steel	68 g
1SC375	1SC375	1000 V	MF-A, MEV70A, MEV100A fuses up to 800A	Zinc-Plated Steel	68 g
1SCM10	1SCM10	1000 V	MF-A, MEV70A, MEV100A fuses up to 800A	Zinc-Plated Steel	68 g

Hybrid Xp Series

700 VDC Max., L/R ≤ 1ms, 35 - 600A

SPECIAL PURPOSE

HYBRID OVER CURRENT PROTECTING DEVICE



X_p product line-up belongs to the new hybrid DC Over-Current Protection (O.C.P.) range developed by Mersen.

It provides maximum flexibility in equipment design and ultimate protection. They have been engineered to provide protection for DC applications: Battery Energy Storage, EV/HEV, Smart-grid, PV installations, etc ...

The X_p system is composed by fast acting pyro element, controlled by a gate current, plus a parallel clearing element.

This protection meets custom requirements of very fast operating time and very high overload current.

TECHNICAL DATA OVERVIEW

Voltage	Up to 1.000VDC
Ampere Range [A]	0 ... 800 A
Switchability	Max. 12kA - 1.000VDC with L/R=5ms
Temperature range	-40 ... 90 °C
Gate control current	2A - 10A [2ms]
Gate control resistance	2,2Ω
L/R max.	5ms
Max switching current / Max inrush current	400A / 400A - 10 sec.
Power dissipation	20W @ 25°C

FEATURES/BENEFITS:

- DC application focused design
- Extremely low watt losses (~20W / 400A)
- Excellent cycling performance
- Ultra-fast acting (300 μs)
- Small footprint
- Large inrush current 15IN for 100ms
- Tunable Time-Current curve

APPLICATIONS:

- 100V to 1,000VDC
- Battery Energy Storage, 100 - 1,000 VDC
- Electric Vehicle, Hybrid Electric Vehicle
- PV installations (1,500VDC in dev.)
- Supercapacitors
- DC General Purposes
- Remote Power Switch Contactor

STANDARDS:

- IATF - ISO/TS 16949 Quality management undergoing certification

SP

TECHNICAL DATA

Xp series DC fuse	
Gate control characteristics	
Triggering time	See figure "Triggering Time"
No Fire Gate Control Current I _G	< 0.8A
Dielectric test after triggering	750VDC
Fire Gate Control Current I _G	1A - 10A
Gate control resistance	2.2 Ω
Gate Control resistance after triggering	>100 Ω
Output characteristics	
Load voltage	Up to 1000VDC
Operating range	100 - 1000VDC
Current	Up to 800A @ I _n
Overload current T=25°C / 240 mm ² connection	600A / 2 mn 1,000A / 10s 2,000A / 5s 7,000A / 100 ms
On state resistance	200 μΩ
Off state resistance	> 5 MΩ
Power dissipation	20 W @ 25°C
Switchability	12kA – 1,000 VDC with L/R = 5ms
System characteristics (can be tailored for you)	
Vibration resistance	ISO 16 750-3 (under qualification)
Mech. shock resistance	ISO 16 750-3 (under qualification)
Temperature cycle resistance	ISO 16 750-4 (under qualification)
Chemical loads resistance	ISO 16 750-5 (under qualification)

SCHEMATICS AND OPERATION

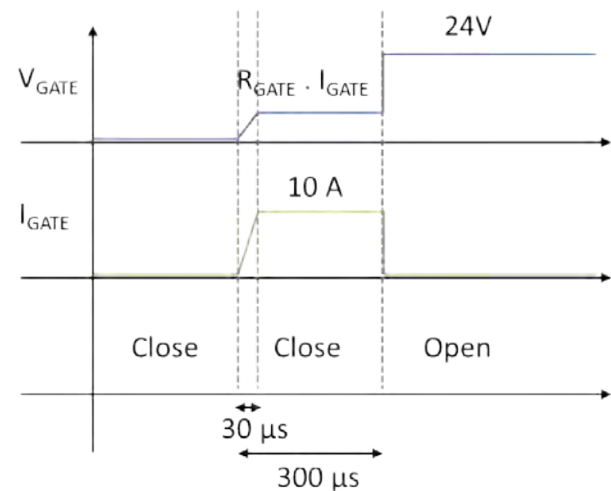
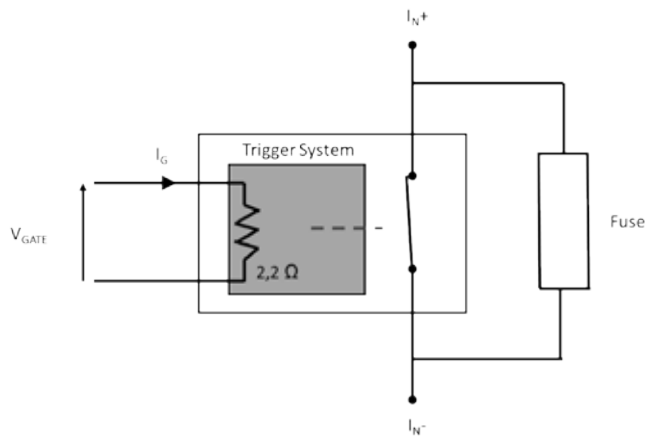

Hybrid X_s-EV Series

700 VDC Max., L/R ≤ 1ms, 35 - 600A

SPECIAL PURPOSE

HYBRID DC POWER RELAY



The new X_s-EV product series is one of the latest developments in Mersen Hybrid DC Power Relays.

X_s-EV have been engineered to provide high DC switching performances versus conventional mechanical power relays. This series addresses DC-applications like, but not limited to, Electrical Energy Storage, EV/HEV, DC Smart-grid, PV installations.

X_s-EV provide maximum flexibility in equipment design and ultimate DC operation performance. This Power Relay is a Hybrid technology with the capability of switching both high voltage and high current, designed specially for electrical vehicle applications.

All information provided in this datasheet relates to prototypes still under development. Most features can be modified to adjust to customers' needs (incl. current/voltage ratings and timings). Some characteristics will require additional testing to confirm preliminary estimation (incl. cycling and extreme environment operation).

TECHNICAL DATA OVERVIEW

Voltage Range DC	500 ... 1200 VDC
Breaking capacity	Up to 2,000 A @ 1,200VDC
Product Size	162 x 66 x 95 mm
Current	300A (nominal)
Device current polarity	Bidirectional
L/R max.	≤ 5ms (for higher rates please contact Mersen)
Weight	0.8 kg

FEATURES/BENEFITS:

- DC specific design
- Bidirectional
- Arc-less
- Reduced footprint & mass
- Low conduction losses
- Repeatable current make/break capability for resistive & inductive loads at full rated voltage and current
- Enhanced cycling performances
- Built-in turn ON fault detection
- Built-in precharging circuit (optional)
- Easily tunable L/R rating (optional)
- Galvanic insulation

APPLICATIONS:

- DC Power Relay for demanding EV applications
- EES
- DC grid protection, PV applications
- Railway

STANDARDS:

- IATF - ISO/TS 16949 Quality management system
- ISO 26262 functional safety (pending)

SP

PRODUCT RANGE



XsEV90B300-B2000

Xs-EV

Catalog number	Rated voltage DC (IEC)	Rated current I _n	Rated breaking capacity DC	Charging circuit	Weight	Package
XsEV90B300-B2000	900 V	300 A	2000 A	No	0.8 kg	1
XsEV90B300-B1500	900 V	300 A	1500 A	No	0.8 kg	1
XsEV120B300-B1500	1200 V	300 A	1500 A	No	0.8 kg	available 2017-03
XsEV120B300-B2000	1200 V	300 A	2000 A	No	0.8 kg	available 2017-03
XsEV120C300-B2000	1200 V	300 A	2000 A	Yes	-	in development

TECHNICAL DATA

	Xs-EV
Bistable	Yes
Degree of protection	IP 30
Circuit break time	Typ. 70 ms (see typical switching behaviour)
Operating temperature	-40°C to 85°C
Wiring cross sections	> 95mm ²
Body Material	PA 12 (colored black)
Max. ON/OFF switching current	Max. ON = 1000A Max. OFF = 500A/1000A/1500A/2000A
Insulation	Resistance > 100MΩ (initially)
Dielectric strength	3000VDC
Internal contact gap	3mm (2 x 1.5mm)
Contact voltage drop	150mV (initially) 175mV (after typical life)
Operating time	Make: Typ. 90 ms Break: Typ. 90 ms (including galvanic insulation)
Power supply voltage (+/-)	18 - 36VDC
Switching & holding current	Switching: Typ. 10A Holding: Typ. 0.1A
Input control voltage (On/Off)	Low level: 0 - 5VDC High level: 8 - 36VDC
Control current (ON/OFF)	40 μA (max)
Tightening torque (recommended)	Power terminals: M8 (15Nm) Base plate: M5 (4Nm)
Vibration resistance	> 6 g (50...2000 Hz) ISO 16750-3 (pending)
Pollution degree	PD 1 (prototype only)
Altitude	Max. 2000m
Number of cycles vs current and L/R	> 20 cycles @ 2000A, 500VDC, L/R = 0.5ms > 2000 cycles @ 300A, 500VDC, L/R = 5ms
Lifetime	> 100.000 cycles (mechanical)
Transient voltage during clearing current	Typ. 1400VDC @ 2000A/900VDC – 1700VDC @ 2000A/1200VDC

TYPICAL SWITCHING BEHAVIOR

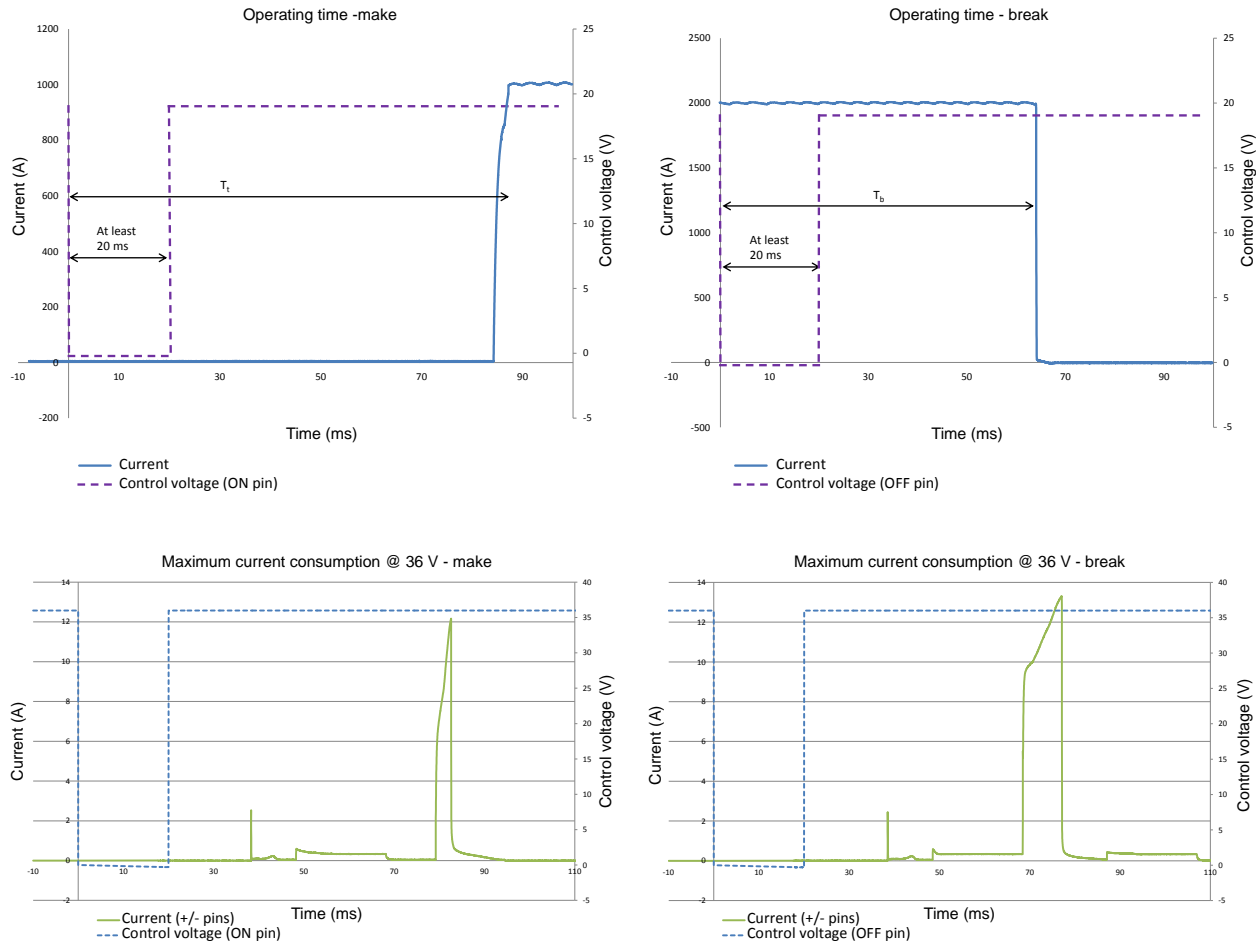

The XsEV is an active-low device. If the on and off pins are connected to high impedance, or not connected, they will be in high level. To switch the device on or off, pull the corresponding pin to low level ($< 5\text{ V}$) during at least 20 ms. After 20 ms the closing or opening sequence starts. A typical command strategy would be to connect the command pin to the ground with a transistor or an optocoupler (see typical electrical connection diagram below).

A command pin will triggered the opening or closing sequence only once, no matter how long it is kept at low level. After it has been brought back to high level, it can be triggered again.

If both pins are triggered at the same time, the opening sequence will start.

SP

DIMENSIONS

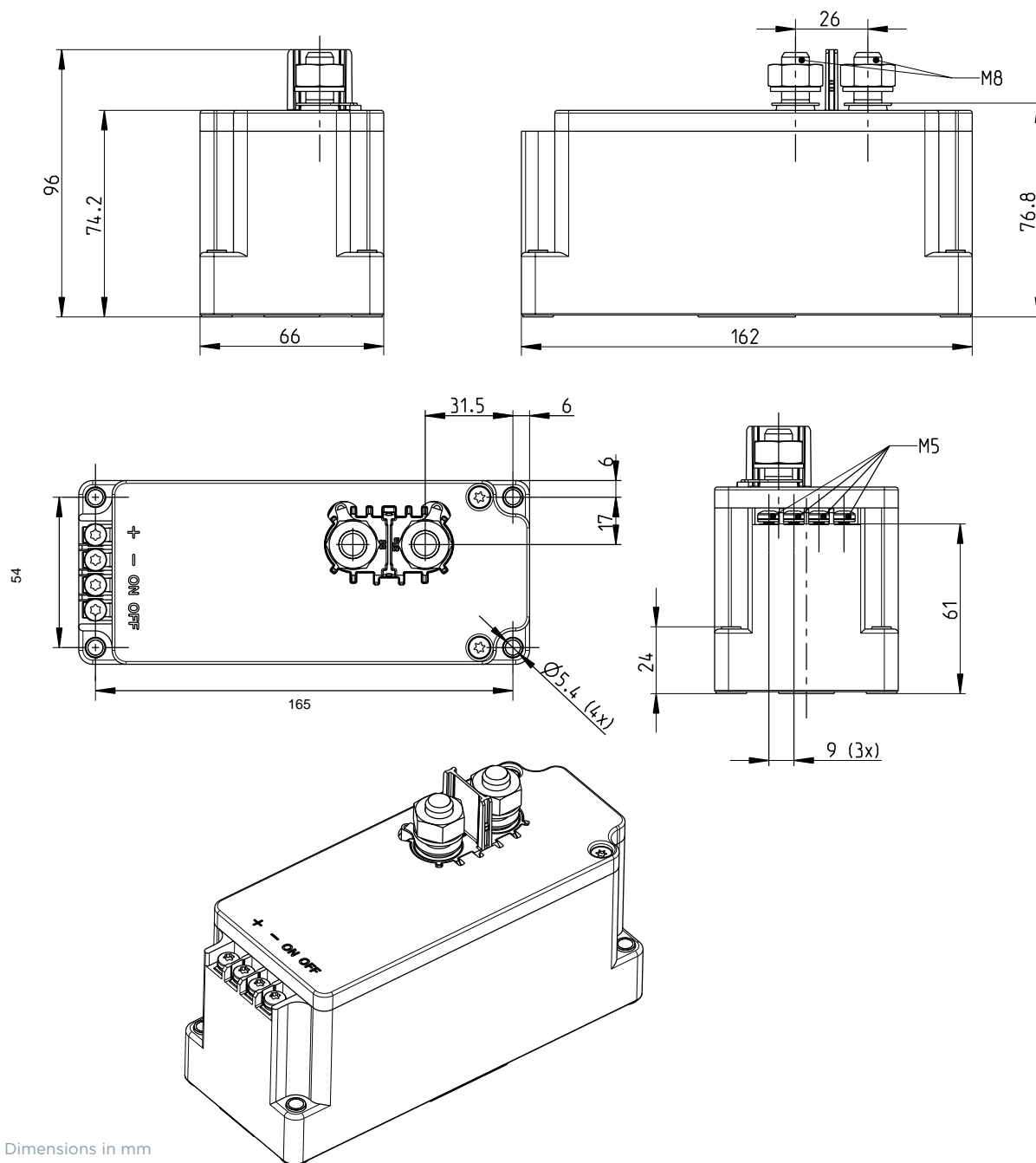

Dimensions in mm

AF, AF2, AF3

Automotive Fuses

SPECIAL PURPOSE

AF

- Automotive fuse
- Fast-acting
- Plastic Body
- Zinc alloy terminals
- ISO 8820-3 compliant

1A through 40A, 32VAC/DC
1000 A I.R.



STANDARD FUSE AMPERE RATINGS

Catalog Number	Ampere Rating	Volts	Body Color
AF-1	1A	32V	BLACK
AF-2	2A	32V	GREY
AF-3	3A	32V	VIOLET
AF-4	4A	32V	PINK
AF-5	5A	32V	TAN
AF-7-1/2	7-1/2A	32V	BROWN
AF-10	10A	32V	RED
AF-15	15A	32V	BLUE
AF-20	20A	32V	YELLOW
AF-25	25A	32V	NATURAL
AF-30	30A	32V	GREEN
AF-35	35A	32V	BLUE GREEN
AF-40	40A	32V	AMBER

AF2

- Automotive fuse
- Fast-acting
- Plastic body
- Zinc alloy terminals
- ISO 8820-3 compliant

2A through 30A, 32VDC
1000 A I.R.



STANDARD FUSE AMPERE RATINGS

Catalog Number	Ampere Rating	Volts	Body Color
AF2-2	2A	32V	GREY
AF2-3	3A	32V	VIOLET
AF2-4	4A	32V	PINK
AF2-5	5A	32V	TAN
AF2-7-1/2	7-1/2A	32V	BROWN
AF2-10	10A	32V	RED
AF2-15	15A	32V	BLUE
AF2-20	20A	32V	YELLOW
AF2-25	25A	32V	NATURAL
AF2-30	30A	32V	GREEN

AF3

- Automotive fuse
- Time-delay
- Plastic body
- Zinc alloy/tin-plated terminals
- ISO 8820-3 compliant

20A through 80A, 32VDC, 1000 A I.R.



STANDARD FUSE AMPERE RATINGS

Catalog Number	Ampere Rating	Volts	Body Color
AF3-20	20A	32V	YELLOW
AF3-30	30A	32V	GREEN
AF3-40	40A	32V	AMBER
AF3-50	50A	32V	RED
AF3-60	60A	32V	BLUE
AF3-70	70A	32V	TAN
AF3-80	80A	32V	NATURAL

SP

AFH, AF2H, AF3H

Automotive Fuse Holders

SPECIAL PURPOSE

AFH

In-line fuseholders for blade type automobile fuses. 4" stranded wire leads are stripped back 1/4".

Catalog Number	Fuse Type & Max Amp	Volts	Body Color	AWG/Color
AFH20-14	AF Fuse/20A	32V	BLACK	#14/BLACK
AFH20-14Y	AF Fuse/20A	32V	YELLOW	#14/BLACK
AFH20-16	AF Fuse/20A	32V	YELLOW	#16/BLACK
AFH20-16Y	AF Fuse/20A	32V	YELLOW	#16/BLACK

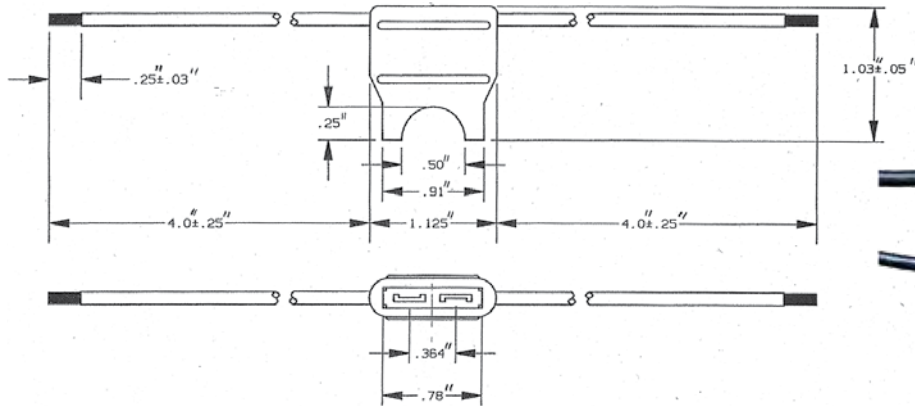

Catalog Number	Fuse Type & Max Amp	Volts	Body Color	AWG/Color
AFH30-12	AF Fuse/30A	32V	BLACK	#12/YELLOW
AFH30C	AF Fuse/30A	32V	BLACK	#12/ORANGE

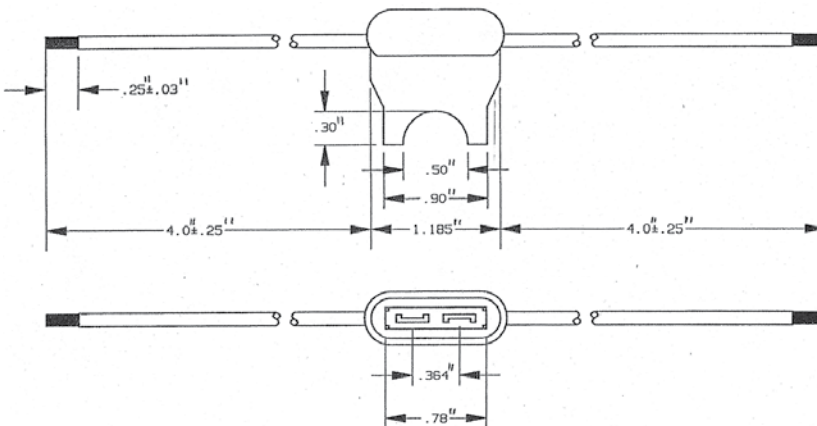

Forklift Truck Fuses

ACK, ACL, ALS, CNL, CNN

SPECIAL PURPOSE

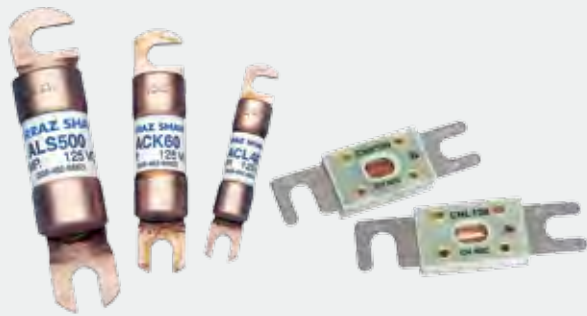

Mersen Forklift Truck and Battery Isolator fuses are specially designed for the heavy duty loads associated with DC battery powered equipment such as forklift trucks, hand trucks, motorized work platforms, and other DC battery operated systems. Rugged construction and stud mounted bolt-in design assure a long life in adverse conditions for these fuses. This expanded line of Forklift Truck Fuses can fulfill virtually all of your heavy duty circuit protection needs up to 125V AC or DC. The round body ACK, ACL and ALS fuses combine higher voltage ratings and more ampere ratings with higher interrupting ratings. The flat CNL and CNN style fuses have a lower voltage rating but are also AC and DC, more space saving and have visual “see-thru” indication to show when they have operated.

FEATURES/BENEFITS:

- All fuses are AC and DC rated
- Expanded ampere ratings
- Time-delay and general purpose types
- Link is visible through window (CNL/CNN)

HIGHLIGHTS:

- AC/DC ratings
- Embossed catalog No's.
- Stud mounted
- Time-delay - ACK
- General purpose - ACL, ALS

APPLICATIONS:

- Forklift trucks
- Battery hand trucks
- Motorized work platforms
- Battery systems

RATINGS:

ACK:

- **Volts:** 125VAC / DC
- **Amps:** 1 to 400A
- **IR:** 10kA I.R. AC / DC

ACL

- **Volts:** 125VAC / DC
- **Amps:** 30 to 120A
- **IR:** 100kA I.R. AC, 10kA I.R. DC

ALS

- **Volts:** 125VAC / DC
- **Amps:** 100 to 500A
- **IR:** 10kA I.R. AC / DC

CNL

- **Volts:** 80V AC / DC
- **Amps:** 35 to 500A
- **IR:** 2.5kA I.R. AC / DC

CNN

- **Volts:** 130V AC
- **Amps:** 10-800A
- **Volts:** 75V DC
- **Amps:** 10 to 300A
- **Volts:** 48V DC
- **Amps:** 301-800A
- **IR:** 2.5kA I.R. AC / DC

APPROVALS:

- UL recognized components (All Products) File E60314 

CATALOG NUMBERS (AMPS)

ACK Fuse				ACL Fuse		ALS Fuse		CNL Fuse				CNN Fuse			
ACK2	ACK25	ACK80	ACK175	ACL30	ACL70	ALS100	ALS300	–	CNL100	CNL250	CNL600	CNN10	CNN100	CNN250	CNN600
ACK3	ACK30	ACK90	ACK200	ACL35	ACL80	ALS150	ALS350	CNL35	CNL125	CNL275	CNL675	CNN35	CNN125	CNN275	CNN225
ACK5	ACK35	ACK100	ACK225	ACL40	ACL90	ALS175	ALS400	CNL40	CNL130	CNL300	–	CNN40	–	CNN300	–
ACK6	ACK40	ACK120	ACK250	ACL50	ACL100	ALS200	ALS450	CNL50	CNL150	CNL325	CNL750	CNN50	CNN150	CNN325	CNN700
ACK10	ACK50	ACK140	ACK300	ACL60	ACL120	ALS225	ALS500	CNL60	CNL175	CNL350	–	CNN60	CNN175	CNN350	–
ACK15	ACK60	ACK150	ACK400			ALS250		CNL80	CNL200	CNL400	–	CNN80	CNN200	CNN400	CNN800
								–	CNL225	CNL500		CNN90	CNN225	CNN500	

RECOMMENDED FUSE BLOCKS FOR FORKLIFT TRUCK FUSES

Fuse	Fuse Block
ACK(70-100)	P243C
ACL(70-120)	P243E
CNL	FTFH, FTFH-1
CNN	FTFH, FTFH-1

DIMENSIONS

Catalog No.	Outline Figure	A	B	C	D	E	F	G
		In. (mm)	In. (mm)	In. (mm)	In. (mm)	In. (mm)	In. (mm)	In. (mm)
ACK 1-30	1	3.07 (77.9)	2.5 (63.5)	.56 (14.3)	.5 (12.7)	.28 (7.1)	.593 (15)	.03 (.8)
ACK 35-60	1	3.74 (95)	3 (76.2)	.81 (20.6)	.75 (19.1)	.34 (8.7)	.86 (21.8)	.047 (1.2)
ACK 70-100	1	4.46 (113.4)	3.5 (88.9)	1.06 (26.9)	1 (25.4)	.38 (9.5)	1.12 (28.5)	.06 (1.6)
ACK 120-200	1	4.72 (119.8)	3.75 (95.4)	1.06 (26.9)	1 (25.4)	.38 (9.5)	1.12 (28.5)	.06 (1.6)
ACK 225-400	1	4.71 (119.7)	3.75 (95.4)	1.06 (26.9)	1 (25.4)	.38 (9.5)	1.12 (28.5)	.06 (1.6)
ACL 30-60	1	3.07 (77.9)	2.5 (63.5)	.56 (14.3)	.5 (12.7)	.28 (7.1)	.593 (15)	.03 (.8)
ACL 70-120	1	3.49 (88.6)	2.75 (69.9)	.81 (20.6)	.75 (19.1)	.34 (8.7)	.86 (21.8)	.047 (1.2)
ALS 100-500	1	4.71 (119.7)	3.75 (95.4)	1.06 (26.9)	1 (25.4)	.38 (9.5)	1.12 (28.5)	.06 (1.6)
CNL/CNN	2	3.188 (80.9)	2.44 (61.9)	.89 (22.6)	.75 (19.0)	.34 (8.7)	--	--

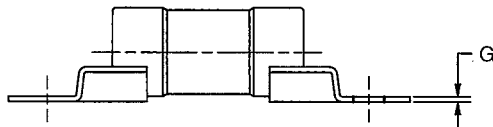
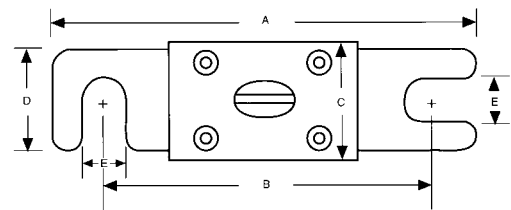
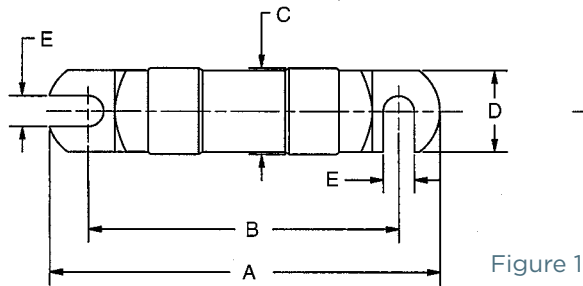

SP

CP

600V Cable Protectors

SPECIAL PURPOSE



Mersen CP Cable Protectors are special purpose limiters which are crimped or bolted to cables or terminals to clear and isolate faults quickly, increasing the reliability of service entrance and distribution runs. CP Cable Protectors have a 200,000A interrupting rating, yet will carry low cable overloads which are handled by standard protective devices. Cable protectors are rated in terms of cable size and material (Al or Cu). Heavier duty CPH cable protectors are available on special order. Heat shrinkable (HS) tubing can be specified for field installation. TI blown fuse trigger indicators may be available upon request. Refer to the application information section for more information.

Type	Description	Termination	Cable Size	Catalog # for Cable Type	
				Copper	Aluminum
1	Cable to Cable		2	CP2C1	-
			1/0	CP1/OC1	-
			2/0	CP2/OC1	-
			4/0	CP4/OC1	CP4/OA1
			250kcmil	CP250C1	CP250A1
			350kcmil	CP350C1	CP350A1
			400kcmil	CP400C1	-
			500kcmil	CP500C1	CP500A1
			600kcmil	CP600C1	CP600A1
			750kcmil	CP750C1	CP750A1
1000kcmil	CP1000C1	-			
3	Cable to Offset Bus		2	CP2C3	-
			1/0	CP1/OC3	-
			2/0	CP2/OC3	-
			4/0	CP4/OC3	CP4/OA3
			250kcmil	CP250C3	CP250A3
			350kcmil	CP350C3	CP350A3
			400kcmil	CP400C3	-
			500kcmil	CP500C3	CP500A3
			600kcmil	CP600C3	CP600A3
			750kcmil	CP750C3	CP750A3
1000kcmil	CP1000C3	-			
5	Straight Bus to Offset Bus		2/0	CP2/OC5	CP2/OC5
			4/0	CP4/OC5	CP4/OC5
			250kcmil	CP250C5	CP250C5
			350kcmil	CP350C5	CP350C5
			500kcmil	CP500C5	CP500C5
			600kcmil	CP600C5	CP600C5
6	Mole to Cable		4/0	CP4/OC6	CP4/OA6
			250kcmil	CP250C6	CP250A6
			350kcmil	CP350C6	CP350A6
			400kcmil	CP400C6	-
			500kcmil	CP500C6	CP500A6
8	Mole to Offset Bus		4/0	CP4/OC8	CP4/OC8
			250kcmil	CP250C8	CP250C8
			350kcmil	CP350C8	CP350C8
			500kcmil	CP500C8	CP500C8
			750kcmil	CP750C8	CP750C8

*Please consult factory for special terminations.

RATINGS:

- **Sizes:** #2 to 1000kcmil aluminum or copper
- **Volts:** 600VAC
- **IR:** 200kA I.R. AC

FEATURES/BENEFITS:

- Fiberglass bodies for dimensional stability in harsh environments
- Catalog number stamped into terminal for permanent identification
- Crimp terminals for aluminum cable include oxide inhibitor
- Molded rubber boots or heat shrinkable tubing available for insulation and protection
- Current limiting device
- Permitted by National Electrical Code®

APPROVALS:



- UL listed to File E305297

Catalog Numbering System	
	CP 500 C 3 - TI
Standard Duty	CP
Heavy Duty	CPH
Conductor Size	500
Cable Material: Copper or Aluminum	C A
Termination	3
Heat Shrink	HS
Trigger Indicator	TI

TYPE C1 - DIMENSIONS (CABLE TO CABLE - COPPER)

Catalog No.	Cable* Size	Dimensions - Inches (mm)					
		A	B	D	E	J	N
CP2C1	#2	.712 [180]	1.44 [37]	.42 [11]	1.75 [44]	3.62 [92]	.31 [7.9]
CP1/OC1	1/0	.712 [180]	1.44 [37]	.52 [13]	1.75 [44]	3.62 [92]	.39 [9.9]
CP2/OC1	2/0	.712 [180]	1.44 [37]	.56 [14]	1.75 [44]	3.62 [92]	.44 [11]
CP4/OC1	4/0	.712 [180]	1.44 [37]	.68 [17]	1.75 [44]	3.62 [92]	.55 [14]
CP250C1	250kcmil	7.38 [188]	1.44 [37]	.75 [19]	1.88 [48]	3.62 [92]	.62 [16]
CP350C1	350kcmil	7.62 [194]	1.62 [41]	.88 [22]	2.00 [51]	3.62 [92]	.71 [18]
CP400C1	400kcmil	7.62 [194]	1.62 [41]	.94 [24]	2.00 [51]	3.62 [92]	.75 [19]
CP500C1	500kcmil	9.38 [238]	1.88 [48]	1.05 [27]	2.88 [73]	3.62 [92]	.85 [22]
CP600C1	600kcmil	9.51 [242]	2.50 [64]	1.07 [27]	2.88 [73]	3.75 [95]	.94 [24]
CP750C1	750kcmil	9.51 [242]	2.50 [64]	1.32 [34]	2.88 [73]	3.75 [95]	1.06 [27]
CP1000C1	1000kcmil	10.00 [254]	3.00 [76]	1.50 [38]	3.13 [79]	3.75 [95]	1.16 [29]

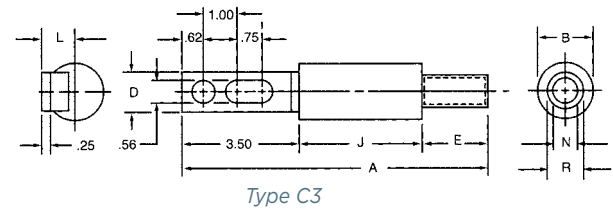
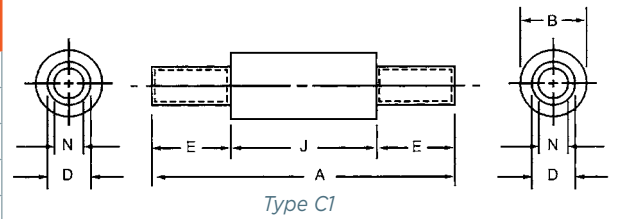

TYPE C3 - DIMENSIONS (CABLE TO OFFSET BUS - COPPER)

Catalog No.	Cable* Size	Dimensions - Inches (mm)									
		A	B	D	E	I	J	L	N	R	
CP2C3	#2	8.87 [225]	1.44 [37]	1.12 [28]	1.75 [44]	3.50 [88.9]	3.62 [92]	.96 [24]	.31 [7.9]	.42 [11]	
CP1/OC3	1/0	8.87 [225]	1.44 [37]	1.12 [28]	1.75 [44]	3.50 [88.9]	3.62 [92]	.96 [24]	.39 [9.9]	.52 [13]	
CP2/OC3	2/0	8.87 [225]	1.44 [37]	1.12 [28]	1.75 [44]	3.50 [88.9]	3.62 [92]	.96 [24]	.44 [11]	.56 [14]	
CP4/OC3	4/0	8.87 [225]	1.44 [37]	1.12 [28]	1.75 [44]	3.50 [88.9]	3.62 [92]	.96 [24]	.55 [14]	.68 [17]	
CP250C3	250kcmil	9.00 [229]	1.44 [37]	1.12 [28]	1.88 [48]	3.50 [88.9]	3.62 [92]	.96 [24]	.62 [16]	.75 [19]	
CP350C3	350kcmil	9.12 [232]	1.62 [41]	1.12 [28]	2.00 [51]	3.50 [88.9]	3.62 [92]	.96 [24]	.71 [18]	.88 [22]	
CP400C3	400kcmil	9.12 [232]	1.62 [41]	1.12 [28]	2.00 [51]	3.50 [88.9]	3.62 [92]	.96 [24]	.75 [19]	.88 [22]	
CP500C3	500kcmil	10.00 [254]	1.88 [48]	1.62 [41]	2.88 [73]	3.50 [88.9]	3.62 [92]	1.19 [30]	.85 [22]	1.05 [27]	
CP600C3	600kcmil	10.13 [257]	2.50 [64]	2.00 [51]	2.88 [73]	3.50 [88.9]	3.75 [95]	1.31 [33]	.94 [24]	1.07 [27]	
CP750C3	750kcmil	10.13 [257]	2.50 [64]	2.00 [51]	2.88 [73]	3.50 [88.9]	3.75 [95]	1.31 [33]	1.06 [27]	1.32 [34]	
CP1000C3	1000kcmil	10.63 [270]	3.00 [76]	2.00 [51]	3.13 [79]	3.75 [95]	3.75 [95]	1.56 [40]	1.16 [29]	1.50 [38]	

TYPE C5 - DIMENSIONS (STRAIGHT BUS TO OFFSET BUS - COPPER)

Catalog No.	Cable Size	Dimensions - Inches (mm)					
		A	B	D	J	L	M
CP4/OC5	4/0	10.37 [263]	1.44 [37]	1.12 [28]	3.62 [92]	.96 [24]	1.12 [28]
CP250C5	250kcmil	10.37 [263]	1.44 [37]	1.12 [28]	3.62 [92]	.96 [24]	1.12 [28]
CP350C5	350kcmil	10.37 [263]	1.62 [41]	1.12 [28]	3.62 [92]	.96 [24]	1.12 [28]
CP400C5	400kcmil	10.37 [263]	1.62 [41]	1.12 [28]	3.62 [92]	.96 [24]	1.12 [28]
CP500C5	500kcmil	10.37 [263]	1.88 [48]	1.62 [41]	3.62 [92]	1.19 [30]	1.50 [38]
CP600C5	600kcmil	10.50 [267]	2.50 [64]	2.00 [51]	3.75 [95]	1.31 [33]	2.00 [51]
CP750C5	750kcmil	10.50 [267]	2.50 [64]	2.00 [51]	3.75 [95]	1.31 [33]	2.00 [51]

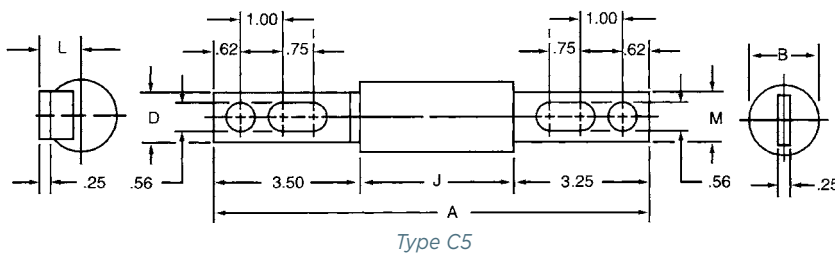

* kcmil = MCM

CABLE TYPE

- TYPE 1—Cable to cable
- TYPE 2—Bus to cable
- TYPE 3—Cable to offset bus
- TYPE 5—Bus to offset bus
- TYPE 6—Mole to cable
- TYPE 7—Bus to bus
- TYPE 8—Mole to offset bus

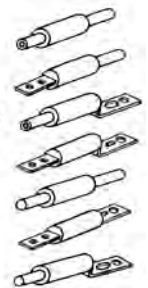

TYPE C6 - DIMENSIONS (MOLE TO CABLE - COPPER)

Catalog No.	Cable* Size	Dimensions - Inches (mm)							
		A	B	E	J	M	N	P	R
CP4/OC6	4/0	7.87 (200)	1.44 (37)	1.75 (44)	3.62 (92)	2.50 (64)	.55 (14)	.52 (13)	.68 (17)
CP250C6	250kcmil	8.00 (203)	1.44 (37)	1.88 (48)	3.62 (92)	2.50 (64)	.62 (16)	.58 (14)	.75 (19)
CP350C6	350kcmil	8.12 (206)	1.62 (41)	2.00 (51)	3.62 (92)	2.50 (64)	.71 (18)	.68 (17)	.88 (22)
CP500C6	500kcmil	9.38 (238)	1.88 (48)	2.88 (73)	3.62 (92)	2.88 (73)	.85 (22)	.81 (21)	1.05 (27)
CP750C6	750kcmil	9.51 (427)	2.50 (64)	2.88 (73)	3.75 (95)	2.88 (73)	1.06 (27)	1.00 (25)	1.32 (34)

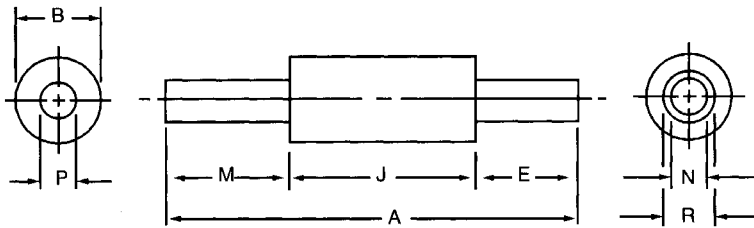

Type C6

TYPE C8 - DIMENSIONS (MOLE TO OFFSET BUS - COPPER)

Catalog No.	Cable* Size	Dimensions - Inches (mm)						
		A	B	D	J	L	M	N
CP4/OC8	4/0	9.62 (244)	1.44 (37)	1.12 (28)	3.62 (92)	.96 (24)	2.50 (64)	.52 (14)
CP250C8	250kcmil	9.62 (244)	1.44 (37)	1.12 (28)	3.62 (92)	.96 (24)	2.50 (64)	.58 (13)
CP350C8	350kcmil	9.62 (244)	1.62 (41)	1.12 (28)	3.62 (92)	.96 (24)	2.50 (64)	.68 (17)
CP500C8	500kcmil	10.00 (254)	1.88 (48)	1.62 (41)	3.62 (92)	1.19 (30)	2.88 (73)	.81 (21)
CP750C8	750kcmil	10.13 (257)	2.50 (64)	2.00 (51)	3.75 (95)	1.31 (33)	2.88 (73)	1.00 (25)

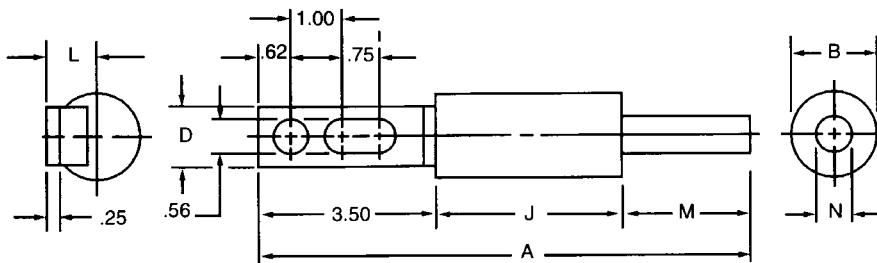

Type C8

* kcmil = MCM

TYPE A1 - DIMENSIONS (CABLE TO CABLE - ALUMINUM)

Catalog No.	Cable* Size	Dimensions - Inches (mm)					
		A	B	J	N	Q	R
CP4/OA1	4/0	13.88 [353]	1.44 [37]	3.62 [92]	.55 [14]	2.50 [64]	.85 [22]
CP250A1	250kcmil	13.88 [353]	1.44 [37]	3.62 [92]	.59 [15]	2.50 [64]	.94 [24]
CP350A1	350kcmil	13.88 [353]	1.62 [41]	3.62 [92]	.71 [18]	2.50 [64]	1.13 [29]
CP500A1	500kcmil	15.38 [391]	1.88 [48]	3.62 [92]	.85 [22]	2.88 [73]	1.33 [34]
CP750A1	750kcmil	15.50 [394]	2.50 [64]	3.75 [95]	1.06 [27]	2.88 [73]	1.62 [41]

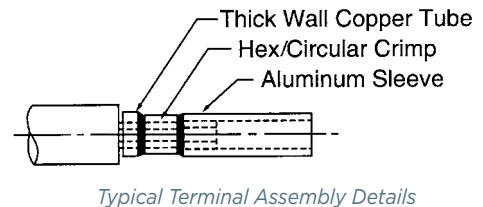
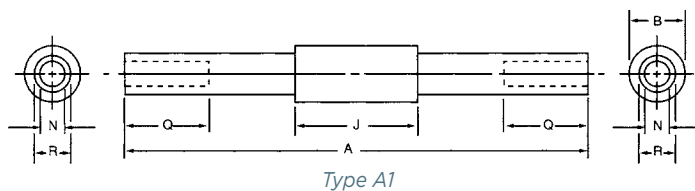

TYPE A3 - DIMENSIONS (CABLE TO OFFSET BUS - ALUMINUM)

Catalog No.	Cable* Size	Dimensions - Inches (mm)							
		A	B	D	J	L	N	Q	R
CP4/OA3	4/0	12.25 [311]	1.44 [37]	1.12 [28]	3.62 [92]	.96 [24]	.55 [14]	2.50 [64]	.85 [22]
CP250A3	250kcmil	12.25 [311]	1.44 [37]	1.12 [28]	3.62 [92]	.96 [24]	.59 [15]	2.50 [64]	.94 [24]
CP350A3	350kcmil	12.25 [311]	1.62 [41]	1.12 [28]	3.62 [92]	.96 [24]	.71 [18]	2.50 [64]	1.13 [29]
CP500A3	500kcmil	13.00 [330]	1.88 [48]	1.62 [41]	3.62 [92]	1.19 [30]	.85 [22]	2.88 [73]	1.33 [34]
CP750A3	750kcmil	13.12 [333]	2.50 [64]	2.00 [51]	3.75 [95]	1.31 [33]	1.06 [27]	2.88 [73]	1.62 [41]

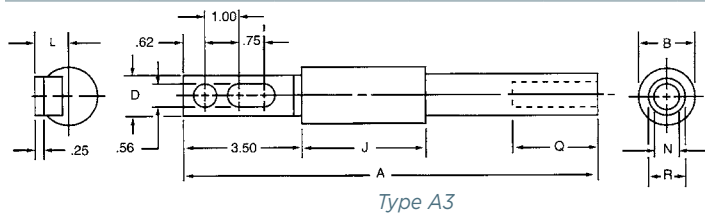

TYPE A6 - DIMENSIONS (MOLE TO CABLE - ALUMINUM)

Catalog Number	Cable* Size	Dimensions - Inches (mm)							
		A	B	E	J	N	P	Q	R
CP4/OA6	4/0	11.25 [286]	1.44 [37]	2.50 [64]	3.62 [92]	.55 [14]	.52 [13]	2.50 [64]	.85 [22]
CP250A6	250kcmil	11.25 [286]	1.44 [37]	2.50 [64]	3.62 [92]	.59 [15]	.58 [14]	2.50 [64]	.94 [24]
CP350A6	350kcmil	11.25 [286]	1.62 [41]	2.50 [64]	3.62 [92]	.71 [18]	.68 [17]	2.50 [64]	1.13 [29]
CP500A6	500kcmil	12.38 [314]	1.88 [48]	2.88 [73]	3.62 [92]	.85 [22]	.81 [21]	2.88 [73]	1.33 [34]
CP750A6	750kcmil	12.50 [318]	2.50 [64]	2.88 [73]	3.75 [95]	1.06 [27]	1.00 [25]	2.88 [73]	1.59 [41]

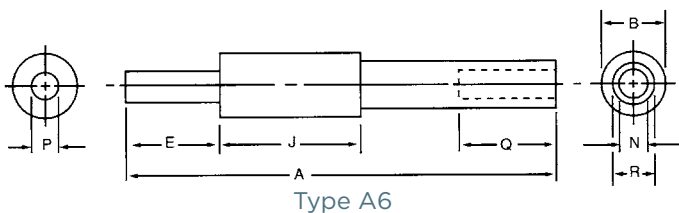

Type 5 - Use Copper Cable Protectors Type C5

Type 8 - Use Copper Cable Protectors Type C8

* kcmil = MCM

Note: Inside surface of sleeve ends is coated with oxide inhibitor and capped.

SP

COPPER CABLE PROTECTORS WITH HEAT SHRINKABLE TUBING*

TYPE C1, COPPER CABLE -
DIMENSIONS

Cable Size	Inches	A (mm)	Catalog No. Cable Protector With Heat Shrinkable Tubing
4/0	7.12	(180)	CP4/0C1-HS
250kcmil	7.38	(188)	CP250C1-HS
350kcmil	7.62	(194)	CP350C1-HS
500kcmil	9.38	(238)	CP500C1-HS
750kcmil	9.51	(242)	CP750C1-HS

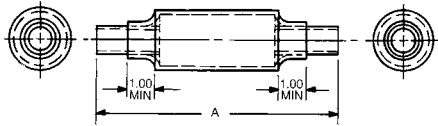

TYPE C3, COPPER CABLE -
DIMENSIONS

Cable Size	Inches	A (mm)	Catalog No. Cable Protector With Heat Shrinkable Tubing
4/0	8.87	(225)	CP4/0C3-HS
250kcmil	9.00	(229)	CP250C3-HS
350kcmil	9.12	(232)	CP350C3-HS
500kcmil	10.00	(254)	CP500C3-HS
750kcmil	10.13	(257)	CP750C3-HS

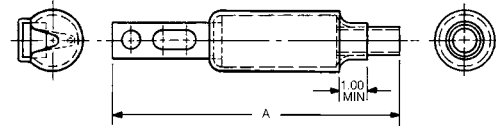

TYPE C5, COPPER CABLE -
DIMENSIONS

Cable Size	Inches	A (mm)	Catalog No. Cable Protector With Heat Shrinkable Tubing
4/0	10.37	(263)	CP4/0C5-HS
250kcmil	10.37	(263)	CP250C5-HS
350kcmil	10.37	(263)	CP350C5-HS
500kcmil	10.37	(263)	CP500C5-HS
750kcmil	10.50	(267)	CP750C5-HS

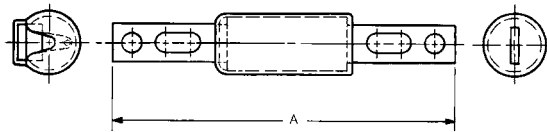

TYPE C6, COPPER CABLE -
DIMENSIONS

Cable Size	Inches	A (mm)	Catalog No. Cable Protector With Heat Shrinkable Tubing
4/0	7.87	(200)	CP4/0C6-HS
250kcmil	8.00	(203)	CP250C6-HS
350kcmil	8.12	(206)	CP350C6-HS
500kcmil	9.38	(238)	CP500C6-HS
750kcmil	9.51	(242)	CP750C6-HS

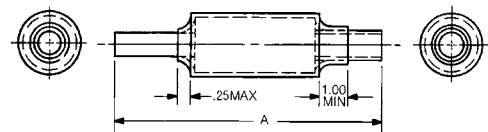

TYPE C8, COPPER CABLE -
DIMENSIONS

Cable Size	Inches	A (mm)	Catalog No. Cable Protector With Heat Shrinkable Tubing
4/0	9.62	(244)	CP4/0C8-HS
250kcmil	9.62	(244)	CP250C8-HS
350kcmil	9.62	(244)	CP350C8-HS
500kcmil	10.00	(254)	CP500C8-HS
750kcmil	10.13	(257)	CP750C8-HS

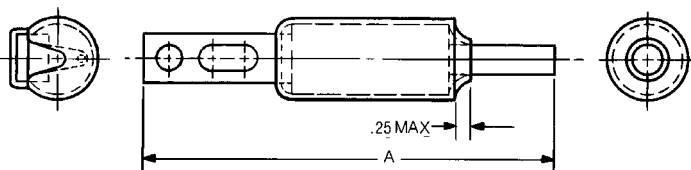

* Transparent heat shrinkable tubing is supplied separately with -HS Catalog No. Maximum curing conditions: 5 seconds at 450°F.

ALUMINUM CABLE PROTECTORS WITH HEAT SHRINKABLE TUBING*

TYPE A1, ALUMINUM CABLE - DIMENSIONS

Cable Size	Inches	A (mm)	Catalog No. Cable Protector With Heat Shrinkable Tubing
4/0	13.88	[353]	CP4/OA1-HS
250kcmil	13.88	[353]	CP250A1-HS
350kcmil	13.88	[353]	CP350A1-HS
500kcmil	15.38	[391]	CP500A1-HS
750kcmil	15.50	[394]	CP750A1-HS

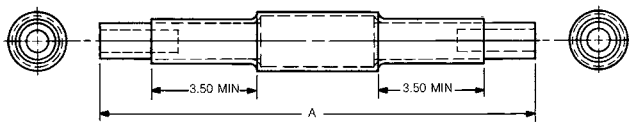

TYPE A3, ALUMINUM CABLE - DIMENSIONS

Cable Size	Inches	A (mm)	Catalog No. Cable Protector With Heat Shrinkable Tubing
250kcmil	12.25	[311]	CP250A3-HS
350kcmil	12.25	[311]	CP350A3-HS
4/0	12.25	[311]	CP4/OA3-HS
500kcmil	13.00	[330]	CP500A3-HS
750kcmil	13.12	[333]	CP750A3-HS

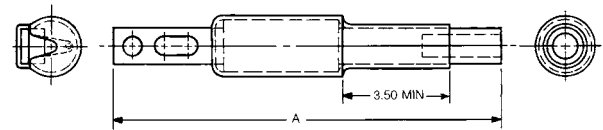

TYPE A6, ALUMINUM CABLE - DIMENSIONS

Cable Size	Inches	A (mm)	Catalog No. Cable Protector With Heat Shrinkable Tubing
4/0	11.25	[286]	CP4/OA6-HS
250kcmil	11.25	[286]	CP250A6-HS
350kcmil	11.25	[286]	CP350A6-HS
500kcmil	12.38	[314]	CP500A6-HS
750kcmil	12.50	[318]	CP750A6-HS

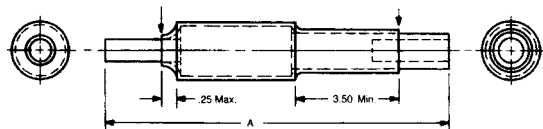

Type 5 - Use Copper Cable Protectors Type C5

Type 8 - Use Copper Cable Protectors Type C8

* Transparent heat shrinkable tubing is supplied separately with -HS Catalog Numbers. Maximum curing conditions: 5 seconds at 450 °F.

MOLDED RUBBER INSULATING SLEEVES**

FOR TYPE C1 COPPER CABLE PROTECTORS - DIMENSIONS

Catalog No.	Cable Size	Dimensions - Inches (mm)						
		A	B	C	D	E	F	G
4/OCCR	4/0	10.44	3.69	3.38	.83	1.33	1.50	2.00
		(265)	(94)	(86)	(21)	(33)	(38)	(51)
500CCR	500kcmil	14.19	3.69	5.25	1.31	1.81	1.94	2.44
		(360)	(94)	(133)	(33)	(46)	(49)	(62)

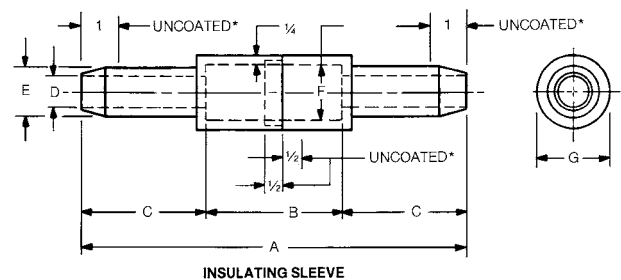

FOR TYPE C3 COPPER CABLE PROTECTORS - DIMENSIONS

Catalog No.	Cable Size	Dimensions - Inches (mm)						
		A	B	C	D	E	F	G
4/OCBR	4/0	7.06	3.69	3.38	.83	1.33	1.50	2.00
		(179)	(94)	(86)	(21)	(33)	(38)	(51)
500CBR	500kcmil	8.94	3.69	5.25	1.31	1.81	1.94	2.44
		(227)	(94)	(133)	(33)	(46)	(49)	(62)

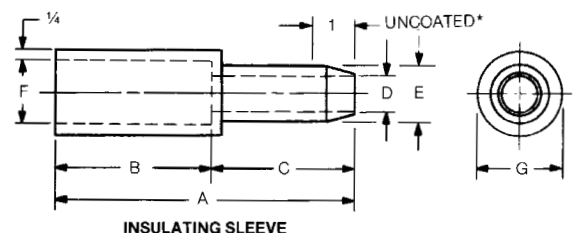

** Molded rubber insulating sleeves are ordered by their own catalog numbers, and not as suffixes to the cable protector catalog numbers. Neoprene coated except as noted.

SP

Mersen Cable Protectors have standard commercial splicing sleeve dimensions. Any crimping tool suitable for standard splicing sleeves, can be used. Follow crimping tool manufacturers instructions. Some crimping tool examples are shown below. It is recommended to use at least 2 crimps.

CABLE PROTECTOR SPLICING SLEVE DIMENSIONS

Cable Size (MCM or kcmil)	Copper		Aluminum	
	ID	OD	ID	OD
#2	0.31 (7.87)	0.42 (10.69)	-	-
1/0	0.39 (9.91)	0.52 (13.21)	-	-
2/0	0.44 (11.18)	0.56 (14.22)	-	-
4/0	0.55 (13.97)	0.68 (17.27)	0.54 (13.8)	0.84 (21.5)
250	0.62 (15.75)	0.75 (19.05)	0.59 (15.1)	0.94 (23.7)
350	0.71 (18.03)	0.88 (22.35)	0.71 (18.0)	1.13 (28.7)
400	0.75 (19.05)	0.94 (23.88)	-	-
500	0.82 (20.83)	1.05 (26.67)	0.84 (21.2)	1.31 (33.3)
600	0.94 (23.88)	1.07 (27.18)	0.92 (23.4)	1.44 (36.6)
750	1.06 (26.92)	1.32 (33.53)	1.03 (26.2)	1.59 (40.4)
1000	1.16 (29.46)	1.50 (38.1)	-	-

PANDUIT - COPPER

Cable Size (MCM or kcmil)	CT-920, CT-920CH, CT-930, CT-930CH, CT-2920	
	Die	Die Color & Die No.
#2	CD-920-2	Brown P33
1/0	CD-920-1/0	Pink P42
2/0	CD-920-2/0	Black P45
4/0	CD-920-4/0	Purple P54
250	CD-920-250*	Yellow P62
350	CD-920-350	Red P71
400	CD-920-400	Blue P76
500	CD-920-500	Brown P87
600	CD-920-600	Green P94
750	CD-920-750	Black P106

* Copper Tap Connector Part Nos: HTCT250-8, HTCT250-2, HTCT250-250

* Tap Connector Die Part No: CD-930H-250

PANDUIT - ALUMINUM

Cable Size (MCM or kcmil)	CT-920, CT-920CH, CT-930, CT-930CH, CT-2920	
	Die	Die Color & Die No.
#2	CD-920-1/0	Pink P42
1/0	CD-920-3/0**	Tan P50 (Orange P50)
2/0	CD-920-4/0	Olive P54 (Purple 54)
4/0	CD-920-300	White P66
250	CD-920-350	Red P71
350	CD-920-500	Brown P87
400	CD-920-600	Green P94
500	CD-920-500A	Pink P99
600	CD-920-750	Black P106
750	-	-

** Aluminum Tap Connector Part No: HTAP2-8-L (PANDUIT Die Color & Die No)

Note: Crimp Tools CT 2940 and CT940H may be used with adapter CD-940-DA

THOMAS & BETTS - COPPER

Cable Size (MCM or kcmil)	13642M (13400) Hydraulic Head		TBM14 (14 TON) Head		TBM15 (15 TON) Head		Head	
	Die Cat No.	Die Code	Die Cat No.	Die Code	Die Cat No.	Die Code	Die Cat No.	Die Code
#2	11735	33	15528	33	15528	33	11402	33
1/0	11737	42	15508	42	15508	42	11334	42
2/0	11738	45	15526	45	15526	45	11405	45
4/0	11740	54	15511	54	15511	54H	11407	54H
250	11771	62	15510-CK	62	15510-CK	62	297-31669-7	62
350	11743	71H	15514-CK	71H	15514-CK	71H	11363	71
400	11744	76H	15512	76H	15512	76H	11410	76
500	11746-TB	87H	15506	87H	15506	87H	11423	87
600	11748	99H	15536-CK	94H	15536-CK	94H	11364	94
750	-	-	15515-CK	106H	15515-CK	106H	74506	106
1000	-	-	-	-	15603	125H	11416	125

THOMAS & BETTS - ALUMINUM

Cable Size (MCM or kcmil)	13642M (13400) Hydraulic Head		TBM14 Head		TBM15 Head		21940 (40 TON) Head	
	Die Cat No.	Die Code	Die Cat No.	Die Code	Die Cat No.	Die Code	Die Cat No.	Die Code
4/0	11742	66H	15534	66H	15534	66H	11409	66
250	11744	76H	15512	76H	15512	76H	11410	76
350	11747	94H	15536-CK	94H	15536-CK	94H	11364	94
400	-	-	-	-	-	-	-	-
500	11749	106H	15515-CK	106H	15515-CK	106H	74506	106
600	11751	112H	15504	115H	15609	112H	11426	112
750	-	-	-	-	15602	140H	11418	140

BURNDY - COPPER

Cable Size (MCM or kcmil)	Burndy Hypress and Die Set			
	Y35	Y39	Y750	Y46*
#2	U2CRT	U2CRT	U2CRT	U2CRT
1/0	U25RT	U25RT	U25RT	U25RT
2/0	U26RT	U26RT	U26RT	U26RT
4/0	U28RT	U28RT	U28RT	U28RT
250	U29RT	U29RT	U29RT	U29RT
350	U31RT	U31RT	U31RT	U31RT
400	U32RT	U32RT	U32RT	U32RT
500	-	U34RT	U34RT	U34RT
600	-	U36RT	U36RT	U36RT
750	-	U39RT	U39RT	U39RT
1000	-	-	-	P44RT**

* Requires PUADP-1 Adapter

** PUADP-1 Adapter not required

Note: Use Burndy Dies with IlSCO ILC-15H crimp tool by installing adapter part no ILD-PADP

BURNDY - ALUMINUM

Cable Size (MCM or kcmil)	Burndy Hypress and Die Set	
	Y35	Y39
#2	-	-
1/0	-	-
2/0	U26ART	U26ART
4/0	U28ART	U28ART
250	U29ART	U29ART
350	U31ART	U31ART
400	U32ART	U32ART
500	-	U34ART
600	-	U36ART
750	-	U39ART-2
1000	-	-

* Requires PUADP-1 Adapter

** PUADP-1 Adapter not required

SP

2CL

250V Cable Protectors

SPECIAL PURPOSE

SP



Mersen 2CL Cable Protectors are special purpose limiters which are crimped or bolted to cables or terminals to clear and isolate faults quickly, increasing the reliability of service entrance and distribution runs. They are 250VAC current limiting with a 200,000A interrupting rating, yet will carry low cable overloads which are handled by standard protective devices. These cable protectors are rated for both copper and aluminum cabling per their corresponding cable size.

Catalog Numbering System				
	2CL	500	B	B
250VAC Cable Limiter				
Conductor Size				
Termination Type 1st End				
Termination Type 2nd End				

*Please consult factory for special terminations.

CATALOG NUMBERS

Type	Termination	Cable Size	Catalog No.
BB	Blade to Blade	1	2CL1BB
		2	2CL2BB
		3	2CL3BB
		4	2CL4BB
		1/0	2CL10BB
		2/0	2CL20BB
		3/0	2CL30BB
		4/0	2CL40BB
		250	2CL250BB
		500	2CL500BB
BF	Blade to Offset Bus	1	2CL1BF
		2	2CL2BF
		3	2CL3BF
		4	2CL4BF
		1/0	2CL10BF
		2/0	2CL20BF
		3/0	2CL30BF
		4/0	2CL40BF
		250	2CL250BF
		350	2CL350BF
500	2CL500BF		
CC	Cable to Cable	1/0	2CL10CC
		2/0	2CL20CC
		4/0	2CL40CC
		250	2CL250CC
		350	2CL350CC
CF	Cable to Offset Bus	1/0	2CL10CF
		2/0	2CL20CF
		4/0	2CL40CF
		250	2CL250CF
		350	2CL350CF
		500	2CL500CF

RATINGS:

- Sizes 1 to 500 kcmil copper and aluminum (CC, CF types copper only)
- **Volts:** 250VAC
- **IR:** 200kA I.R. AC

FEATURES/ BENEFITS:

- Fiberglass bodies for dimensional stability in harsh environments
- Catalog number stamped into terminal for permanent identification
- 250VAC Rated
- Shorter in length, smaller dimensions than standard 600VAC rated cable limiters

APPROVALS:

- Self Certified

A60C

Low Voltage Capacitor Fuses

SPECIAL PURPOSE

600V LOW VOLTAGE CAPACITOR FUSES



Mersen low voltage capacitor fuses provide advanced safety for power correction and harmonic filtering equipment. A capacitor fuse isolates a shorted capacitor before it can damage surrounding equipment or personnel. Typical capacitor failures occur when the internal dielectric can no longer withstand the applied voltage, resulting in a low impedance current path and generating excessive heat and pressure that can cause violent case rupture. Mersen low voltage capacitor fuses will isolate the shorted capacitor before case rupture occurs while routinely withstanding inrush current at startup.

CATALOG NUMBERS (AMPS)

Without indicator	With indicator
A60C10-121	-
A60C15-121	-
A60C20-121	-
A60C25-121	A60C25-121TI
A60C30-121	-
A60C35-121	A60C35-121TI
A60C40-121	A60C40-121TI
A60C50-121	A60C50-121TI
A60C60-121	A60C60-121TI
-	A60C75-121TI
A60C80-121	A60C80-121TI
A60C100-121	A60C100-121TI
A60C125-121	A60C125-121TI
A60C150-121	A60C150-121TI
A60C175-121	A60C175-121TI
A60C200-121	A60C200-121TI
A60C225-121	A60C225-121TI
A60C250-121	A60C250-121TI
A60C300-121	A60C300-121TI

DIMENSIONS

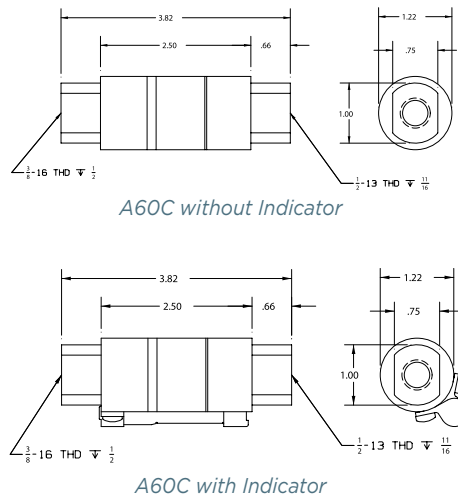

RATINGS:

- **Volts:** 600VAC
- **Amps:** 10 to 300A
- **IR:** 200kA I.R.

FEATURES/ BENEFITS:

- High interrupting rating
- Current-limiting
- Capacitor inrush withstand capability
- Direct mount
- Optional blown fuse indication

APPROVALS:

- UL Recognized Component File E60314
- Tested by UL to CSA standard C22.2 No. 248.1



A4BX

Welder Protectors

SPECIAL PURPOSE



SP

Mersen Welder Protectors are special purpose limiters used to provide isolation of faulted welding equipment and protection for the cable drop supplying the welder. Welder Protectors have a high thermal capacity and are less affected by high ambient temperatures and extended weld times than similar size Class J, K, or R fuses*. Welder Protectors should only be applied for isolation of short circuited welding circuits. Overload protection must be provided for by other means. Contact factory for Class L sizes and ratings.

A4BX (amps) - 150J; Class J Dimensions									
Ampere Rating	Inches								
	A	B	C	D	E	F	G	H	
200	5-3/4	1-1/2	3/16	1-1/8	1-1/2	4-3/8	3/8	9/32	
225-400	7-1/8	2	1/4	1-5/8	2-3/16	5-1/4	17/32	13/32	

A4BX (amps) - 150; Class K Dimensions									
Ampere Rating	A	B	C	D	E	F	G	H	
100	7-7/8	1	1/8	23/32	2-5/8	-	-	-	
125-200	9-5/8	1-1/2	3/16	1-1/8	3-7/16	-	-	-	
225-400	11-5/8	2	1/4	1-5/8	4-7/16	-	-	-	
500-600	13-3/8	2-1/2	1/4	2	5-5/16	-	-	-	

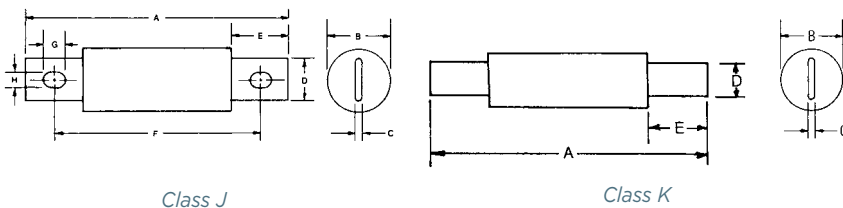

RATINGS:

- **Volts:** 600VAC
- **Amps:** 100 to 600A
- **IR:** 200kA I.R.

APPROVALS:

- Self Certified

CATALOG NUMBERS (AMPS)

Class K Dimension	Class J Dimension
A4BX100-150	-
A4BX125-150	-
A4BX150-150	-
A4BX200-150	A4BX200-150J
A4BX225-150	A4BX225-150J
A4BX300-150	A4BX300-150J
A4BX400-150	A4BX400-150J
A4BX500-150	-
A4BX600-150	-

*For larger ratings consult factory.

A2Y/A6Y

Form 600 Fuses

SPECIAL PURPOSE

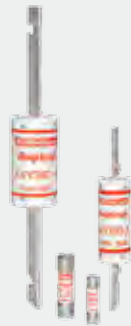

Mersen Form 600 fuses are the original current-limiting fuses, pre-dating all the standards. Their 500V DC rating (through 600A) is a useful feature for special fusing applications. Form 600 fuses provide a high degree of current limitation in AC and DC applications. Types 1 and 3 are dimensionally interchangeable with Class H and K fuses. Types 4 and 5 have unique rejection dimensions and are not interchangeable.

CATALOG NUMBERS (AMPS)

250V				600V			
A2Y1-1	A2Y70-4	A2Y200-3	A2Y450-3	A6Y1-1	A6Y70-4	A6Y200-3	A6Y450-3
A2Y2-1	A2Y70-5	A2Y200-4	A2Y450-4	A6Y2-1	-	A6Y200-4	A6Y450-4
A2Y3-1	A2Y80-3	-	-	A6Y3-1	A6Y80-3	A6Y200-5	A6Y450-5
A2Y5-1	A2Y80-4	-	A2Y500-3	A6Y5-1	A6Y80-4	A6Y225-3	A6Y500-3
A2Y6-1	A2Y90-3	-	A2Y500-4	A6Y6-1	A6Y90-3	A6Y225-4	A6Y500-4
A2Y8-1	A2Y90-4	-	A2Y500-5	A6Y8-1	-	A6Y225-5	A6Y500-5
A2Y10-1	A2Y100-3	A2Y250-3	A2Y600-3	A6Y10-1	A6Y100-3	A6Y250-3	A6Y600-3
A2Y15-1	A2Y100-4	A2Y250-4	A2Y600-4	A6Y15-1	A6Y100-4	A6Y250-4	A6Y600-4
A2Y20-1	A2Y125-3	-	A2Y600-5	A6Y20-1	A6Y125-3	A6Y250-5	A6Y600-5
A2Y25-1	A2Y125-4	A2Y300-3	-	A6Y25-1	A6Y125-4	A6Y300-3	A6Y650-4
A2Y30-1	-	A2Y300-4	-	A6Y30-1	A6Y125-5	A6Y300-4	A6Y800-4
A2Y35-1	A2Y150-3	-	-	A6Y35-1	A6Y150-3	A6Y300-5	A6Y800-5
A2Y40-1	A2Y150-4	A2Y350-3	-	A6Y40-1	A6Y150-4	A6Y350-3	A6Y1000-4
A2Y45-1	-	A2Y350-4	-	A6Y45-1	A6Y150-5	A6Y350-4	A6Y1000-5
A2Y50-1	A2Y175-3	A2Y400-3	-	A6Y50-1	A6Y175-3	A6Y400-3	A6Y1200-4
A2Y60-1	A2Y175-4	A2Y400-4	-	A6Y60-1	A6Y175-4	A6Y400-4	A6Y1200-5
A2Y70-3	-	-	-	A6Y70-3	A6Y175-5	A6Y400-5	-

RATINGS:

A2Y

- **Volts:** 250VAC, 500VDC
- **Amps:** 1 to 600A
- **IR:** 200kA I.R.AC, 100kA I.R. DC

A6Y

- **Volts:** 600VAC, 500VDC
- **Amps:** 1 to 8A (500VAC), 10 to 1200A (600VAC), 1 to 600A (500VDC)
- **IR:** 200kA I.R. AC, 100kA I.R. DC

APPROVALS:

- UL Recognized Component File E60314
- DC Tested to UL248-1 (1-600A)



SP

TYPE 1, 1-60 AMPS CLASS K DIMENSIONS

Ampere Rating	Inches: A2Y - 1-60A		Inches: A6Y - 1-60A	
	A	B	A	B
1-30	2	9/16	5	13/16
35-60	3	13/16	5-1/2	1-1/16

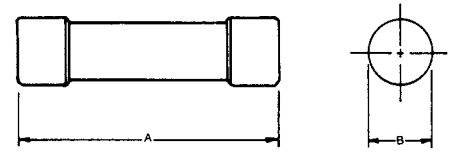

Type 1 1-60A

TYPE 3, 70-600 AMPS, CLASS K DIMENSIONS

Ampere Rating	Inches					
	A	B	C	D	E	J
250 VAC/500 VDC - A2Y (Amp) - 3						
70-100	5-7/8	1	1/8	23/32	1-5/8	2-21/32
125-200	7-1/8	1-1/2	3/16	1-1/8	2-3/16	2-25/32
225-400	8-5/8	2	1/4	1-5/8	2-15/16	2-25/32
450-600	10-3/8	2-1/2	1/4	2	3-13/16	2-25/32
600 VAC/500 VDC - A6Y (Amp) - 3						
70-100	7-7/8	1	1/8	23/32	2-5/8	2-21/32
110-200	9-5/8	1-1/2	3/16	1-1/8	3-7/16	2-25/32
225-400	11-5/8	2	1/4	1-5/8	4-7/16	2-25/32
450-600	13-3/8	2-1/2	1/4	2	5-5/16	2-25/32

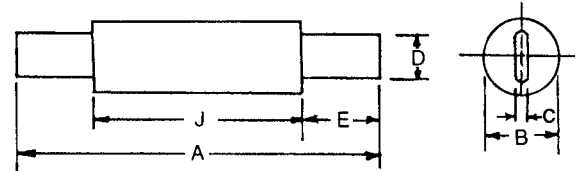

Type 3 70-600A

TYPE 4, 70-600 AMPS - DIMENSIONS

Ampere Rating	Inches								
	A	B	C	D	E	F	H	J	P
250 VAC/500 VDC - A2Y (Amp) - 4									
70-100	5-7/8	1	1/8	23/32	1-5/8	4-7/8	13/64	2-21/32	1/2
125-200	7-1/8	1-1/2	3/16	1-1/8	2-3/16	5-3/4	17/64	2-25/32	11/16
225-400	8-5/8	2	1/4	1-5/8	2-15/16	6-3/4	21/64	2-25/32	15/16
450-600	10-3/8	2-1/2	1/4	2	3-13/16	8-1/8	25/64	2-25/32	1-1/8
600 VAC/500 VDC - A6Y (Amp) - 4									
70-100	7-7/8	1	1/8	23/32	2-5/8	6-7/8	13/64	2-21/32	1/2
125-200	9-5/8	1-1/2	3/16	1-1/8	3-7/16	8-1/4	17/64	2-25/32	11/16
225-400	11-5/8	2	1/4	1-5/8	4-7/16	9-3/4	21/64	2-25/32	15/16
450-600	13-3/8	2-1/2	1/4	2	5-5/16	11-1/8	25/64	2-25/32	1-1/8

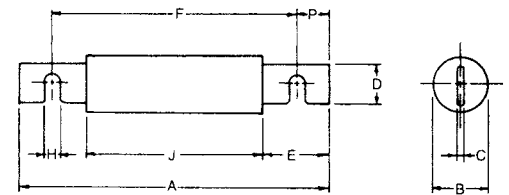

Type 4 70-600A

TYPE 4, 650-1200 AMPS - DIMENSIONS

Ampere Rating	Inches							
	A	B	D	E	F	J	K	Q
600 VAC only - A6Y (Amp) - 4								
650-1200	10-1/2	3	2	3-3/8	7-7/8	3-3/4	1-5/16	5/8

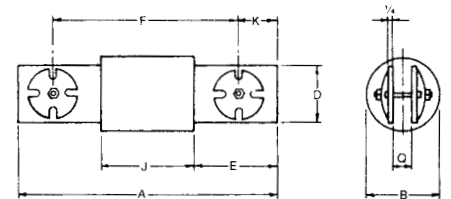

Type 4 650-1200A

TYPE 5, 125-600 AMPS - DIMENSIONS

Ampere Rating	Inches									
	A	B	C	D	E	F	G	H	J	P
600 VAC/500 VDC - A6Y (Amp) - 5										
125-200	10-3/4	1-1/2	3/16	1-1/8	3-7/16	8-1/4	3/4	17/64	2-25/32	11/16
225-400	13-1/4	2	1/4	1-5/8	4-7/16	9-3/4	7/8	21/64	2-25/32	15/16
450-600	15-3/16	2-1/2	1/4	2	5-5/16	11-1/8	1	25/64	2-25/32	1

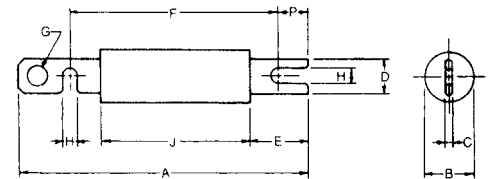

Type 5 125-600A

TYPE 5, 650-1200 AMPS - DIMENSIONS

Ampere Rating	Inches							
	A	B	D	E	F	J	K	Q
600 VAC only - A6Y (Amp) - 5								
650-1200	12-1/8	3	2	3-3/8	7-7/8	3-3/4	1-5/16	5/8

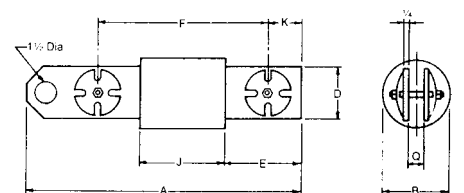

Type 5 650-1200A

HP6M

600V DC Midget (10x38mm) Photovoltaic Fuses

SPECIAL PURPOSE

FOR STRING PROTECTION



Mersen's HP6M photovoltaic (PV) fuse series is designed specifically for the protection of PV string wiring for 600VDC residential and commercial rooftop photovoltaic systems. Its enhanced construction makes it ideal for continuous temperature and current cycling withstand adding to system longevity. The 600VDC rated HP6M, designed for low minimum breaking capacity capabilities of 1.35 times the fuse rated current value, allows for safe circuit interruption under typical low fault current conditions produced by PV arrays. Protect your rooftop PV system from unexpected ground faults and string faults using Mersen's HeliProtection® fuse line.

APPLICATIONS:

- All photovoltaic applications
- PV string/array level protection
- Combiner box applications
- In-line PV module protection
- Inverters
- Battery charge controllers

CATALOG NUMBERS - FUSE HOLDER

	UltraSafe™ Non-Indicating	UltraSafe™ Indicating
Screw Type	USM1HEL	USM1IHEL
Spring Type	USGM1HEL	USGM1IHEL

For additional information, view catalog page for USCC & USM UltraSafe™ Fuse holders.

RATINGS:

- **Volts:** 600VDC
- **Amps:** 1 to 30A
- **IR:** 10kA I.R. DC
- **MBC:** 1.35 x In
- Photovoltaic Fuse, gPV

FEATURES/BENEFITS:

- Low fault current interrupting capability
- Durable construction for enhanced system longevity
- Temperature cycle withstand capability
- Guaranteed operation at temperature extremes
- Industry's first UL Listed Solution
- Globally accepted
-

APPROVALS:

- UL Listed to Standard UL2579 File E333668
- CSA Component Certified C22.2
- IEC 60269-6 Approved



CATALOG NUMBERS AND ELECTRICAL CHARACTERISTICS

Voltage (VDC)	Amperage (A)	Catalog Number	Reference Number	Watts Loss @ 70% x I _n (W)	Watts Loss @ 80% x I _n (W)	Watts Loss @ 100% x I _n (W)	Interrupting Rating (kA)	Size (mm)
600	1	HP6M1	L1018565	0.14	0.19	0.31	10	10x38
	2	HP6M2	M1018566	0.19	0.26	0.43		
	3	HP6M3	N1018567	0.64	0.85	1.4		
	4	HP6M4	Q1018569	0.58	0.77	1.3		
	5	HP6M5	R1018570	0.65	0.87	1.4		
	6	HP6M6	S1018571	0.69	0.92	1.5		
	7	HP6M7	T1018572	0.83	1.11	1.8		
	8	HP6M8	V1018573	0.92	1.23	2.0		
	10	HP6M10	X1018575	0.96	1.28	2.1		
	12	HP6M12	Y1018576	1.12	1.49	2.5		
	15	HP6M15	Z1018577	0.99	1.32	2.2		
	20	HP6M20	A1018578	1.25	1.67	2.8		
	25	HP6M25	K1018610	1.38	1.84	3.1		
	30	HP6M30	L1018611	1.50	2.00	3.3		

DIMENSIONS

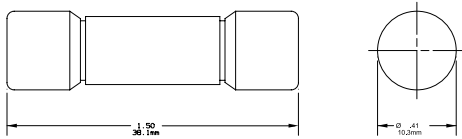

SP

HP10M

1000V DC Midget (10x38mm) Photovoltaic Fuses

SPECIAL PURPOSE

FOR STRING PROTECTION



Mersen's HP10M photovoltaic (PV) fuse series was developed specifically for the protection of PV string wiring for 1000VDC industrial rooftop and utility scale photovoltaic systems. Its robust construction makes it ideal for continuous temperature and current cycling withstand adding to system longevity. The 1000VDC rated HP10M, designed for low minimum breaking capacity capabilities of 1.35 times the fuse rated current value, allows for safe circuit interruption under typical low fault current conditions produced by PV arrays. In addition to the standard ferrule terminal, parts are available with Crimp Cap terminals for in-line fuse applications. The unique wire crimp terminal (CC option) permits solderless wire-to-fuse connection for overmold encapsulation of fuse and wiring. Protect your off-grid or grid tied PV system from unexpected string faults using Mersen's Helioprotection® fuse line.

CATALOG NUMBERS - FUSE HOLDER

	UltraSafe™ Non-Indicating	UltraSafe™ Indicating
Screw Type	USM1HEL	USM1IHEL
Spring Type	USGM1HEL	USGM1IHEL

For additional information, view catalog page for USCC & USM UltraSafe™ Fuse holders.

RATINGS:

- **Volts:** 1000VDC
- **Amps:** 1 to 32A
- **IR:** 50kA I.R. DC
- **MBC:** 1.35 x In
- Photovoltaic Fuse, gPV

FEATURES/BENEFITS:

- Low fault current interrupting capability
- Durable construction for enhanced system longevity
- Temperature cycle withstand capability
- Guaranteed operation at temperature extremes
- Industry's first UL Listed Solution
- Globally accepted

APPLICATIONS:

- All photovoltaic applications
- PV string/array level protection
- Combiner box applications
- In-line PV module protection
- Inverters
- Battery charge controllers

APPROVALS:

- UL Listed to Standard UL2579 File E333668
- CSA Component Certified C22.2
- IEC 60269-6 Approved



CATALOG NUMBERS AND ELECTRICAL CHARACTERISTICS

Voltage [VDC]	Amperage [A]	Catalog Number	Reference Number	Watts Loss @ 70% $\times I_n$ [W]	Watts Loss @ 80% $\times I_n$ [W]	Watts Loss @ 100% $\times I_n$ [W]	Interrupting Rating [kA]	Size [mm]
1000	1	HP10M1	B1018579	0.13	0.18	0.25	50	10x38 (Figure 1)
	2	HP10M2*	C1018580	0.16	0.25	0.32		
	3	HP10M3*	D1018581	0.66	0.87	1.36		
	3.5	HP10M3-1/2	H1043977	0.67	0.84	1.31		
	4	HP10M4*	E1018582	0.69	0.80	1.25		
	5	HP10M5*	F1018583	0.59	0.73	1.12		
	6	HP10M6	G1018584	0.42	0.67	1.05		
	7	HP10M7	H1018585	0.40	0.64	1.00		
	8	HP10M8	J1018586	0.77	0.88	1.48		
	10	HP10M10*	L1018588	0.67	0.9	1.5		
	12	HP10M12*	M1018589	0.72	1.0	1.8		
	15	HP10M15*	N1018590	0.9	1.3	2.2		
	20	HP10M20*	P1018591	1.1	1.5	2.8		
	25	HP10M25*	D1023825	1.3	1.8	3.0		
	30	HP10M30*	E1023826	1.63	2.12	3.93		
	32	HP10M32*	H1062170	1.7	2.3	4.0		
	1	HP10M1CC	F1061616	0.14	0.19	0.27	50	10 x 65 (Figure 2)
	2	HP10M2CC	G1061617	0.17	0.27	0.35		
	3	HP10M3CC	H1061618	0.72	0.95	1.49		
	3.5	HP10M3-1/2CC	J1061619	0.74	0.92	1.43		
	4	HP10M4CC	K1061620	0.76	0.88	1.38		
	5	HP10M5CC	L1061621	0.65	0.80	1.23		
	6	HP10M6CC	J1061527	0.46	0.74	1.15		
	7	HP10M7CC	K1061528	0.44	0.70	1.1		
	8	HP10M8CC	L1061529	0.85	0.97	1.63		
	10	HP10M10CC	M1061530	0.74	0.99	1.65		
	12	HP10M12CC	N1061531	0.79	1.1	1.98		
	15	HP10M15CC	P1061532	0.99	1.43	2.42		
	20	HP10M20CC	Q1061533	1.21	1.65	3.08		
	25	HP10M25CC	R1061534	1.43	1.98	3.3		
	30	HP10M30CC	S1061535	1.63	2.12	3.93		
	32	HP10M32CC	T1061536	1.7	2.3	4.0		

* Available in 176-piece bulk pack (add -B suffix to Catalog Number). Order quantity of one (1) -B suffix Catalog Number yields 176 fuses.

DIMENSIONS

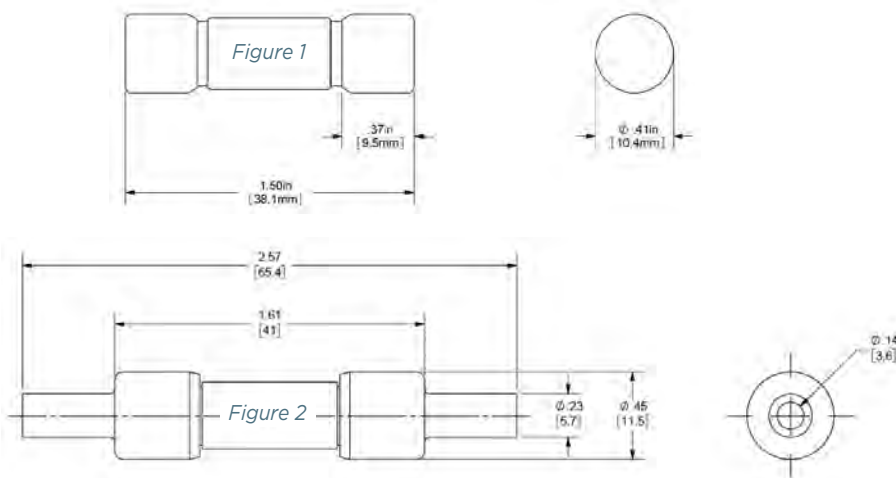

CC terminal (Fig. 2): Recommended crimping tool: T & B Sta-Kon ERG4002 #10 -12 AWG (6-4 mm²)

HP15M

1500VDC Midget (10x85mm) Photovoltaic Fuses

SPECIAL PURPOSE

FOR STRING PROTECTION

SP



Mersen's HP15M photovoltaic (PV) fuse series is designed specifically for the protection of PV string wiring for 1500VDC utility scale photovoltaic systems. Its robust construction makes it ideal for continuous temperature and current cycling withstand adding to system longevity. The 1500VDC rated HP15M, designed for low minimum breaking capacity capabilities of 1.35 times the fuse rated current value, allows for safe circuit interruption under typical low fault current conditions produced by PV arrays and meets the trend for increased voltage for higher efficiency. In addition to the standard ferrule terminal, parts are available with Crimp Cap terminals for in-line fuse applications. The unique wire crimp terminal (CC option) permits solderless wire-to-fuse connection for overmold encapsulation of fuse and wiring. Protect your off-grid or grid tied PV system from unexpected line faults using Mersen's HelioProtection® fuse line.

APPLICATIONS:

- All photovoltaic applications
- PV string/array level protection
- Combiner box applications
- In-line PV module protection
- Inverters
- Battery charge controllers

RATINGS:

- **Volts:** 1500VDC
- **Amps:** 4A - 32A
- **SCCR:** 50kA

Photovoltaic Fuse

FEATURES/BENEFITS:

- Low fault current interrupting capability
- Durable construction for enhanced system longevity
- Temperature cycle withstand capability
- Guaranteed operation at temperature extremes
- Globally accepted
- Recommended Fuse holder: US15M1HEL

APPROVALS:

- UL Listed to Standard UL2579
- CSA Component Pending
- IEC 60269-6



CATALOG NUMBERS AND ELECTRICAL CHARACTERISTICS

Voltage [VDC]	Amperage [A]	Catalog Number	Reference Number	Watts Loss @ 70% x I _n [W]	Watts Loss @ 80% x I _n [W]	Watts Loss @ 100% x I _n [W]	Interrupting Rating [kA]	Size [mm]
1500	4	HP15M4*	F1059569	1.03	1.43	2.58	50	10x85 (Figure 1)
	5	HP15M5*	X1055053	0.83	1.14	1.97		
	6	HP15M6*	Q1053667	0.96	1.36	2.44		
	7	HP15M7	R1053668	0.98	1.38	2.46		
	8	HP15M8	S1053669	1.03	1.50	2.60		
	10	HP15M10*	T1053670	1.24	1.79	3.10		
	12	HP15M12	V1053671	1.16	1.71	2.90		
	15	HP15M15*	W1053672	1.28	1.78	3.20		
	20	HP15M20*	X1053673	1.72	2.49	4.30		
	25	HP15M25*	Y1053674	2.14	3.10	5.40		
	30	HP15M30*	Z1053675	2.58	3.60	6.46		
	32	HP15M32*	G1059570	2.84	3.94	7.12		
	4	HP15M4CC**	A1061542	1.03	1.43	2.58		
	5	HP15M5CC**	B1061543	0.83	1.14	1.97		
	6	HP15M6CC**	D1061545	0.96	1.36	2.44		
	7	HP15M7CC	E1061546	0.98	1.38	2.46		
	8	HP15M8CC	F1061547	1.03	1.50	2.60		
	10	HP15M10CC**	G1061548	1.24	1.79	3.10		
	12	HP15M12CC	H1061549	1.16	1.71	2.90		
	15	HP15M15CC**	J1061550	1.28	1.78	3.20		
	20	HP15M20CC**	K1061551	1.72	2.49	4.30		
	25	HP15M25CC**	L1061552	2.14	3.10	5.40		
	30	HP15M30CC**	M1061553	2.58	3.60	6.46		
	32	HP15M32CC**	N1061554	2.84	3.94	7.12		

* Available in 88-piece bulk pack (add -B suffix to Catalog Number). Order quantity of one (1) -B suffix Catalog Number yields 88 fuses.
 ** Available in 50-piece bulk pack (add -B suffix to Catalog Number). Order quantity of one (1) -B suffix Catalog Number yields 50 fuses.

DIMENSIONS

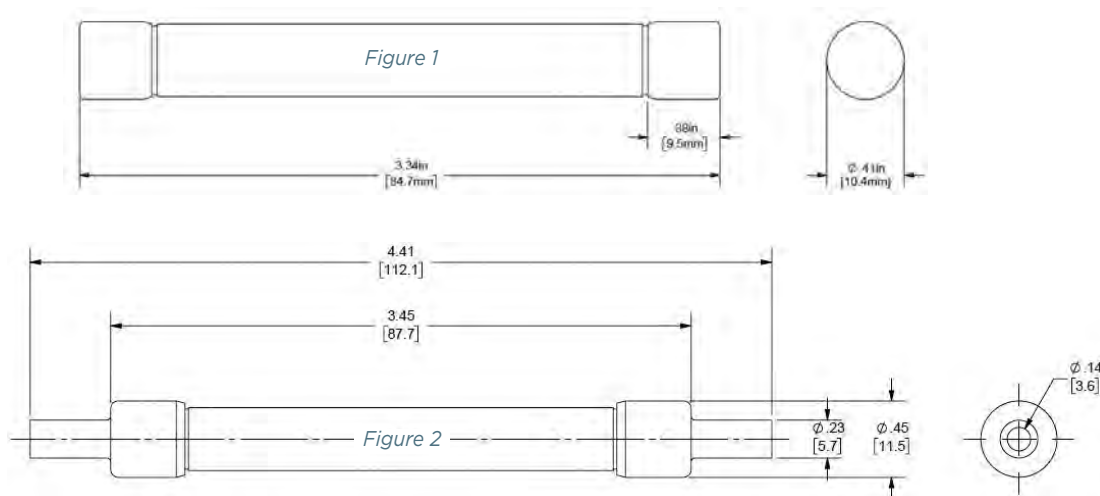

CC terminal (Fig. 2): Recommended crimping tool: T & B Sta-Kon ERG4002 #10 -12 AWG (6-4 mm²)

SP

HP15G

1500VDC Class G (10x57mm) Photovoltaic Fuses

SPECIAL PURPOSE

FOR INLINE PV MODULE PROTECTION



Mersen's HP15G photovoltaic (PV) fuse series was engineered specifically for PV module ground fault protection of photovoltaic systems. Its enhanced construction makes it ideal for continuous temperature and current cycling withstand adding to system longevity. The 1500VDC rated HP15G, designed for low minimum breaking capacity capabilities of 1.35 times the fuse rated current value, allows for safe circuit interruption under typical low ground fault current conditions produced by PV arrays. In addition to the standard ferrule terminal, these products are available with Crimp Cap terminals for in-line fuse applications. The unique wire crimp terminal (CC option) permits solderless wire-to-fuse connection for overmold encapsulation of fuse and wiring. Protect your off-grid or grid tied PV system from unexpected ground faults and string faults using Mersen's HeliProtection® fuse line.

APPLICATIONS:

- In-line PV module protection

RATINGS:

- **Volts:** 1500VDC
- **Amps:** 2½A-5A
- **IR:** HP15G2½ to 4A, Self Certified to 50kA I.R.; HP15G5, 10kA I.R.
- **MBC:** 1.35 x In

Photovoltaic Fuse, gPV

FEATURES/BENEFITS:

- Low fault current interrupting capability
- Durable construction for enhanced system longevity
- Temperature cycle withstand capability
- Guaranteed operation at temperature extremes
- Industry's first UL Listed Solution
- Globally accepted
- Available in standard and bulk packaging options

APPROVALS:

- UL Listed to Standard UL2579 File E333668
- IEC 60269-6



CATALOG NUMBERS AND ELECTRICAL CHARACTERISTICS

Voltage (VDC)	Amperage (A)	Catalog Number	Interrupting Rating (kA)	Size (mm)
1500	2½	HP15G2½*	50	10 x 57 (Figure 1)
	3	HP15G3*		
	3½	HP15G3½*		
	4	HP15G4*		
	5	HP15G5*	10	
	2½	HP15G2½CC**	50	10 x 85 (Figure 2)
	3	HP15G3CC**		
	3½	HP15G3½CC**		
	4	HP15G4CC**		
	5	HP15G5CC**		

* Standard package: 5 fuses. Bulk package (-B suffix) quantity: 88 fuses. Ordering one (1) -B suffixed Catalog Number will yield 88 fuses.

** Standard package: 4 fuses. Bulk package (-B suffix) quantity: 70 fuses. Ordering one (1) -B suffixed Catalog Number will yield 70 fuses.

DIMENSIONS

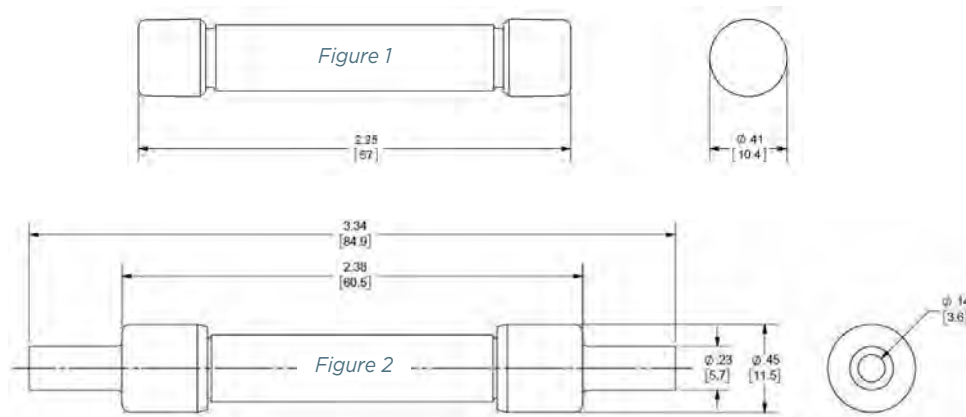

CC terminal (Fig. 2): Recommended crimping tool: T & B Sta-Kon ERG4002 #10 -12 AWG (6-4 mm²)

SP

HP6J

600V DC Class J Photovoltaic Fuses

SPECIAL PURPOSE

FOR ARRAY PROTECTION



Mersen's HP6J photovoltaic (PV) fuse series was engineered specifically for DC Recombiner Boxes in the protection of 600VDC photovoltaic systems. Its enhanced construction makes it ideal for continuous temperature and current cycling withstand adding to system longevity. The 600VDC rated HP6J designed for low minimum breaking capacity capabilities of 1.35 times the fuse rated current value allows for safe circuit interruption under typical low fault current conditions produced by PV arrays. Protect your off-grid or grid tied PV system from unexpected ground faults and line faults using Mersen's HeliProtection(r) fuse line.

CATALOG NUMBERS (AMPS)

Frame Size 1		Frame Size 2		Frame Size 3		Frame Size 4
HP6J70	HP6J90	HP6J110	HP6J175	HP6J225	HP6J350	HP6J450
HP6J80	HP6J100	HP6J125	HP6J200	HP6J250	HP6J400	HP6J500
		HP6J150		HP6J300		HP6J600

CATALOG NUMBERS - FUSE HOLDER

Box Terminal to Box Terminal Configuration, 1-Pole						
Ampere Rating	Clip Configuration	Wire Range	Wire Type	Stud Type	Catalog No.	Temperature Rating of Wire Terminal
100	In-line	2/0 - #6	Cu	-	61006HRJ	90° C
200	Side	350kcmil - #6	Al/Cu	-	62001HRJ	
400	In-line	(2) 350kcmil - #6		-	64031HRJ	
600	In-line	(2) 500kcmil - #4		-	6631HRJ	75° C

For additional configurations and information view Mersen's Solar Power Solutions Guide at <http://ep-us.mersen.com/solarpower>

RATINGS:

- **Volts:** 600VDC
- **Amps:** 70 to 600A
- **IR:** 10kA I.R. DC
- **MBC:** 1.35 x In
- Photovoltaic Fuse

FEATURES/BENEFITS:

- Smallest footprint in the industry
- UL class J dimensions
- Low fault current interrupting capability
- Durable construction for enhanced system longevity
- Temperature cycle withstand capability
- Guaranteed operation at temperature extremes
- Industry's first UL Listed Solution
- Globally accepted

APPLICATIONS:

- Re-combiner (sub-combiner, array combiner, master combiner) applications
- Inverter DC input protection
- Battery charge controllers

APPROVALS:

- UL Listed to Standard UL2579 File E333668
- CSA Component Certified C22.2



ELECTRICAL SPECIFICATIONS

Catalog Number	Ampere Rating (A)	Voltage (VDC)	Interrupting Rating (kA)	Watts Loss @ 80% x In (W)	Watts Loss @ 100% x In (W)
HP6J70	70	600	10	5.8	10
HP6J80	80	600	10	6.4	11
HP6J90	90	600	10	7.5	13
HP6J100	100	600	10	8.1	14
HP6J110	110	600	10	10.4	18
HP6J125	125	600	10	11	19
HP6J150	150	600	10	12.8	22
HP6J175	175	600	10	13.9	24
HP6J200	200	600	10	15.1	26
HP6J225	225	600	10	17.4	30
HP6J250	250	600	10	20.9	36
HP6J300	300	600	10	22	38
HP6J350	350	600	10	23.2	40
HP6J400	400	600	10	24.4	42
HP6J450	450	600	10	33.6	58
HP6J500	500	600	10	34.2	59
HP6J600	600	600	10	39.4	68

DIMENSIONS

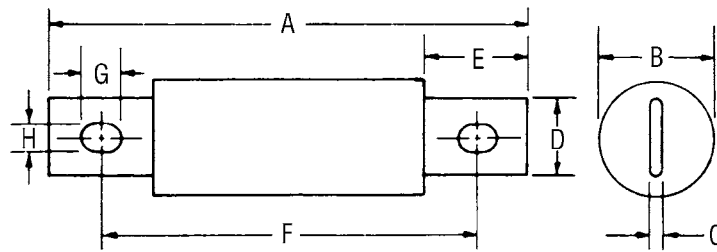

Frame Size	Ampere Rating	A		B		C		D		E		F		G		H	
		in	mm	in	mm	in	mm	in	mm	in	mm	in	mm	in	mm	in	mm
1	70-100	4-5/8	117	1-1/16	27	1/8	3.2	3/4	19	1	25	3-5/8	92	3/8	10	9/32	7
2	110-200	5-3/4	146	1-5/8	41	3/16	4.8	1-1/8	29	1-3/8	35	4-3/8	111	17/32	14	9/32	7
3	225-400	7-1/8	181	2-1/8	54	1/4	6.3	1-7/8	41	1-7/8	48	5-1/4	133	17/32	14	13/32	10
4	450-600	8	203	2-1/2	64	3/8	9.5	2	51	2-1/8	54	6	152	11/16	18	17/32	13

HP10J

1000V DC Class J Photovoltaic Fuses

SPECIAL PURPOSE

FOR ARRAY PROTECTION



Mersen's HP10J photovoltaic (PV) fuse series is designed specifically for DC Recombiner Boxes in the protection of 1000VDC photovoltaic systems. Its robust construction makes it ideal for continuous temperature and current cycling withstand adding to system longevity. The 1000VDC rated HP10J designed for low minimum breaking capacity capabilities of 1.35 times the fuse rated current value, allows for safe circuit interruption under typical low fault current conditions produced by PV arrays. Protect your off-grid or grid tied PV system from unexpected ground faults and line faults using Mersen's HeliProtection® fuse line.

APPLICATIONS:

- Re-combiner box (sub-combiner, array combiner, master combiner) applications
- Inverter DC input
- Battery charge controllers

CATALOG NUMBERS (AMPS)

Frame Size 1		Frame Size 2		Frame Size 3
HP10J70	HP10J125	HP10J250	HP10J350	HP10J450
HP10J80	HP10J160	HP10J300	HP10J400	HP10J500
HP10J100	HP10J200			HP10J600

- For NH3 mounting on 200A to 400A, add suffix "XL" to catalog number (ex. HP10J400XL). 200A part number is HP10J200/400XL.
- For mechanical blown fuse indication, add suffix "EI" to the catalog number (ex. HP10J200EI).
- When using the EI Indicator, if remote blown fuse signal is desired, select AOS-Q (quick connect terminal) or AOS-S (screw terminal).
- Mersen AOS (Add-on switches) contain one single-pole double-throw (NO-NC) contact rated 4 amperes resistive and 1 ampere inductive at 250VAC maximum.

RATINGS:

- **Volts:** 1000VDC (70A to 600A), 600VAC (70A to 400A)
- **Amps:** 70A to 600A
- **IR:** 65kA @ 1000VDC, 200kA@ 600VAC
- **MBC:** 1.35 x In
- Photovoltaic Fuse

SP

FEATURES/BENEFITS:

- UL Listed to standard 2579 - Photovoltaic Fuses
- Smallest available footprint in the industry
- Enlarged mounting holes
- Low fault current interrupting capability
- Durable construction for enhanced system longevity
- Temperature cycle withstand capability
- Guaranteed operation at temperature extremes
- Blown fuse indicator options available (EI option)
- 200A to 400A available in NH3 mounting

APPROVALS:

- UL listed to Standard 2579 File E333668 (70A to 600A)
- UL listed to Standard 248 File E2137 (70A to 400A)
- CSA Component Certified C22.2 (70A to 400A)



Class J PV Fuse, 1000VDC, 65kA IR DC, Frame Size 1



Catalog Number	Reference Number	Rated Current I _n (Amps)	Power Dissipation at 0.7xI _n (Watts)	Power Dissipation at 0.8xI _n (Watts)	Power Dissipation at 1.0xI _n (Watts)	Package
HP10J70	Z1040749	70	3	5	10	1
HP10J80	A1040750	80	4	5	10	1
HP10J100	B1040751	100	6	7	15	1
HP10J125	C1040752	125	5	7	14	1
HP10J160	D1040753	160	6	8	16	1
HP10J200	E1040754	200	10	15	27	1

Class J PV Fuse, 1000VDC, 65kA IR DC, Frame Size 2



Catalog Number	Reference Number	Rated Current I _n (Amps)	Power Dissipation at 0.7xI _n (Watts)	Power Dissipation at 0.8xI _n (Watts)	Power Dissipation at 1.0xI _n (Watts)	Package
HP10J250	F1040755	250	13	18	34	1
HP10J300	G1040756	300	16	22	37	1
HP10J350	H1040757	350	17	24	45	1
HP10J400	J1040758	400	19	27	52	1

Class J PV Fuse, 1000VDC, 65kA IR DC, Frame Size 3



Catalog Number	Reference Number	Rated Current I _n (Amps)	Power Dissipation at 0.7xI _n (Watts)	Power Dissipation at 0.8xI _n (Watts)	Power Dissipation at 1.0xI _n (Watts)	Package
HP10J450	K1040759	450	22	27	56	1
HP10J500	K1047107	500	22	31	58	1
HP10J600	L1047108	600	30	43	82	1

Fuse Blocks for Class J PV Fuse, Frame Size 1, 1-Pole, 1000VDC, 100kA SCCR



Catalog Number	Reference Number	Rated Current I _n (Amps)	Terminal Configuration	Wire Range	Wire Insulation Rating	Package
62001HPJ	S1037385	200	Box-Box	350kcmil - #6	90°C	1
62041HPJ	Q1043961	200	Box-Stud	350kcmil - #6	90°C	1
62011HPJ	Q1033680	200	Stud-Stud	350kcmil - #6	90°C	1

Fuse Blocks for Class J PV Fuse, Frame Size 2, 1-Pole, 1000VDC, 100kA SCCR



Catalog Number	Reference Number	Rated Current I _n (Amps)	Terminal Configuration	Wire Range	Wire Insulation Rating	Package
64031HPJ	T1037386	400	Box-Box	(2) 350kcmil - #6	90°C	1
64041HPJ	R1043962	400	Box-Stud	(2) 350kcmil - #6	90°C	1
64011HPJ	S1043963	400	Stud-Stud	(2) 350kcmil - #6	90°C	1

Fuse Blocks for Class J PV Fuse, Frame Size 3, 1-Pole, 1000VDC, 100kA SCCR



Catalog Number	Reference Number	Rated Current I _n (Amps)	Terminal Configuration	Wire Range	Wire Insulation Rating	Package
6631HPJ		600	Box-Box	(2) 350kcmil - #6	90°C	1
6641HPJ		600	Box-Stud	(2) 350kcmil - #6	90°C	1
6611HPJ		600	Stud-Stud	(2) 350kcmil - #6	90°C	1

DIMENSIONS

Class J (250-400A,
1000V DC)

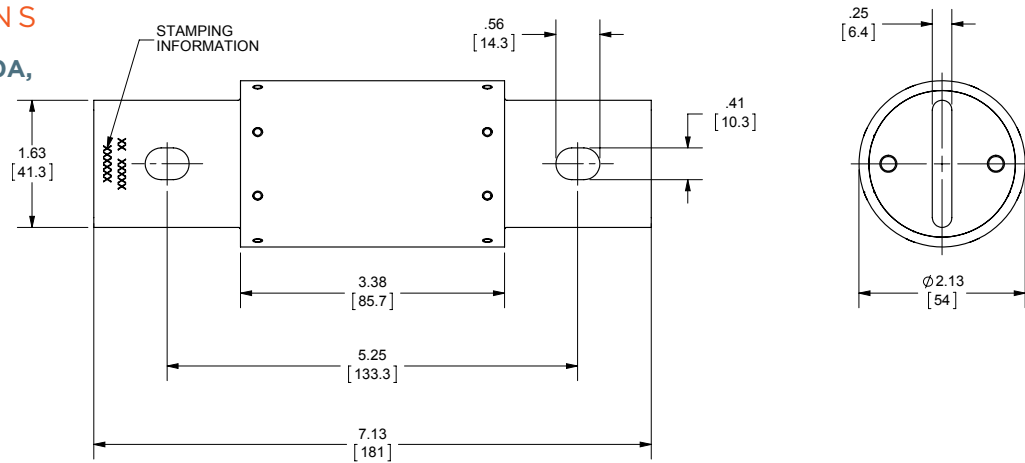

Class J EI (250-400A, 1000V DC)

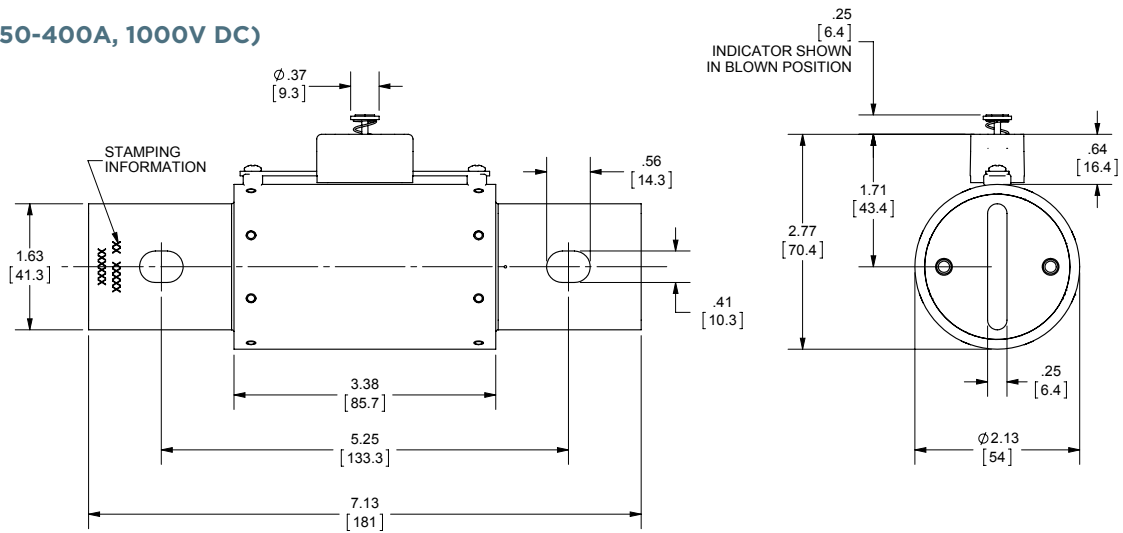

Class J (450-600A, 1000V DC)

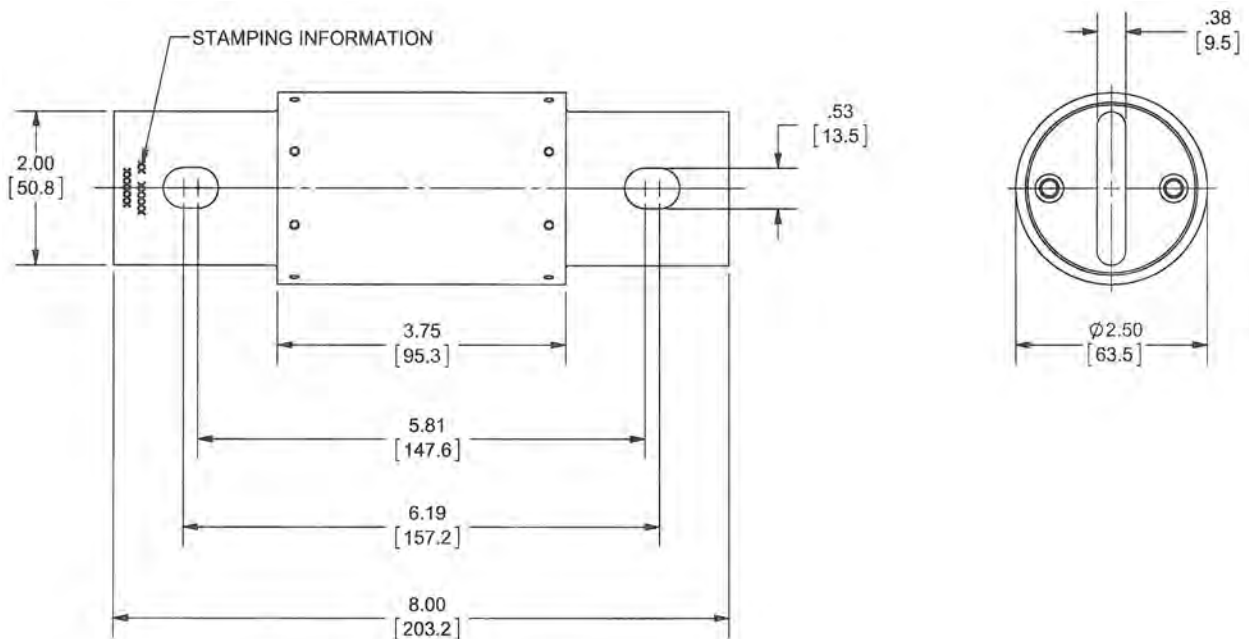

SP

HP10NH

1000V DC Size NH Photovoltaic Fuses

SPECIAL PURPOSE

FOR ARRAY PROTECTION



The HeliProtection® HP10NH photovoltaic (PV) fuse series was engineered and designed specifically for the protection of photovoltaic arrays. Its enhanced fuse construction is designed to withstand constant fluctuations in temperature and current cycling adding to system longevity. Low minimum breaking capacity of 1.35 times the fuse rated current value meets IEC and UL standards, allowing for safe circuit interruption under typical low fault current conditions produced by PV arrays. Typical applications include re-combiner box, master combiner box and inverter inputs.

CATALOG NUMBERS (AMPS)

Size NH1			Size NH2
HP10NH1GPV50	HP10NH1GPV80	HP10NH1GPV125	HP10NH2GPV200
HP10NH1GPV63	HP10NH1GPV100	HP10NH1GPV160	HP10NH2GPV250

CATALOG NUMBERS - FUSE BLOCK

Catalog Number	Ampere Rating (A)	Voltage Rating (V)	No. of Poles	For use with	Description
HPBB11PPR	250	1000	1	NH1	Open Style
HPBB11PPRFS					Open Style with Protective Cover
HPBB21PPR	315	1000	1	NH2	Open Style
HPBB21PPRFS					Open Style with Protective Cover

For additional information view the HPBB open style fuse block data sheet

CATALOG NUMBER - ACCESSORY

Catalog Number	NHHANDLE	Description
		Fuse Puller for Size NH 00-4

RATINGS:

- **Volts:** 1000VDC
- **Amps:** 50 to 250A
- **IR:** 50kA I.R. DC
- **MBC:** 1.35 x In
- Photovoltaic Fuse, gPV

FEATURES/BENEFITS:

- Global acceptance
- Low fault current interrupting capability
- Durable construction for enhanced system longevity
- Temperature cycle withstand capability
- High efficiency with low power losses

APPLICATIONS:

- Re-combiner box (sub-combiner, array combiner, master combiner) applications
- Inverter DC input
- Battery charge controllers

APPROVALS:

- IEC 60269-6 Certification
- UL Listed to standard 2579, File E358319



ELECTRICAL SPECIFICATIONS

Catalog Number	Reference Number	Size	Ampere Rating (A)	Voltage Rating (VDC)	Interrupting Rating (kA)	Watts Loss @ 70% x In (W)	Watts Loss @ 100% x In (W)
HP10NH1GPV50	Z1028283	NH1	50	1000	50	4.6	11
HP10NH1GPV63	A1028284	NH1	63	1000	50	5.4	13
HP10NH1GPV80	B1028285	NH1	80	1000	50	6.1	15
HP10NH1GPV100	C1028286	NH1	100	1000	50	7.2	17
HP10NH1GPV125	D1028287	NH1	125	1000	50	7.4	18
HP10NH1GPV160	E1028288	NH1	160	1000	50	9.6	23
HP10NH2GPV200	X1037619	NH2	200	1000	50	12	29
HP10NH2GPV250	Y1037620	NH2	250	1000	50	14	34

DIMENSIONS (MM)

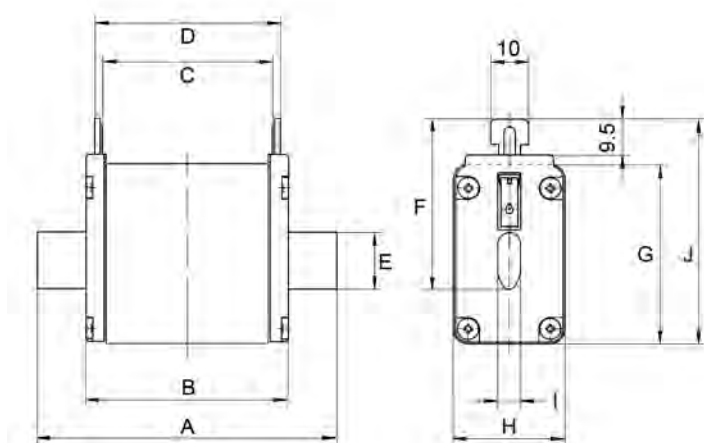

Size	A	B	C	D	E	F	G	H	I	J
NH1	135	70.8	63	68	20	40	52.5	39.5	6	64.5
NH2	150	68	63	68	26	48.5	60	51	6	72

HP12NH

1250V DC Size NH Photovoltaic Fuses

SPECIAL PURPOSE

FOR ARRAY PROTECTION



Mersen's HP12NH photovoltaic (PV) fuse series was engineered and designed specifically for the protection of photovoltaic systems. HeliProtection® HP12NH fuse links are designed for the protection of cables in a PV group of chains when a short circuit occurs in a panel (main fuse category). This HeliProtection main fuse range enables us to offer a full range of protection with worldwide acceptance. They are of the gPV type and comply with both IEC 60269-6 and UL 2579 PV standards.

CATALOG NUMBERS (AMPS)

Size NH1XL	Size NH2XL	Size NH3L	
HP12NH1XLGPV125	HP12NH2XLGPV200	HP12NH3LGPV250	HP12NH3LGPV350
HP12NH1XLGPV160	HP12NH2XLGPV250	HP12NH3LGPV315	HP12BH3LGPV400

APPROVALS:

- UL Listed to 2579, photovoltaic fuse, File E358319
- IEC 60269-6 Certified, gPV
- RoHS Compliant



SP

CATALOG NUMBERS AND ELECTRICAL CHARACTERISTICS

SIZE	Voltage (VDC)	Amperage (A)	PLAIN BLADE		DIRECT MOUNTING		Watts Loss @ 70% x In (W)	Watts Loss @ 100% x In (W)	Inter-rupting Rating (kA)
			Catalog Number	Reference Number	Catalog Number	Reference Number			
NH1XL	1250	125	HP12NH1XLGPV125	G1039744	HP12NH1LGPV125B	K1048671	12	29	50
		160	HP12NH1XLGPV160	H1039745	HP12NH1LGPV160B	L1048672	14	34	
NH2XL		200	HP12NH2XLGPV200	J1039746	HP12NH2LGPV200B	M1048673	16	42	
		250	HP12NH2XLGPV250	K1039747	HP12NH2LGPV250B	N1048674	17	45	
NH3L		250	HP12NH3LGPV250	Z1033389	HP12NH3LGPV250B	P1048675	18	46	
		315	HP12NH3LGPV315	A1033390	HP12NH3LGPV315B	Q1048676	22	53	
		350	HP12NH3LGPV350	B1033391	HP12NH3LGPV350B	R1048677	23	55	
		400	HP12BH3LGPV400	C1033392	HP12NH3LGPV400B	S1048678	29	73	

DIMENSIONS (MM)

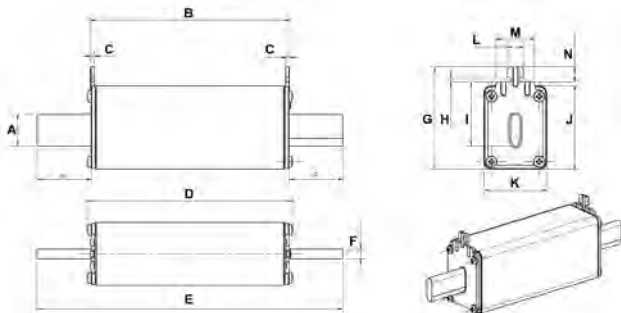

Size	A	B	C	D	E	F	G	H	I	J	K	L	M	N
NH1	20	125.5	2.5	129.6	192.5	6	64.5	2.75	40.5	52.5	39.5	10	24	9.5
NH2	26	123	2.5	127	205	6	72	2.75		60	51	10	24	9.5
NH3	33	123	2.5		205		84.5	2.75	60	74	70	10	25	9.5

CATALOG NUMBERS - OPEN FUSE BASES AND FUSE-BASES WITH TOUCH PROTECTION

For use with	Voltage (VDC)	Amperage (A)	Design	Catalog Number
NH fuse-links NH1XL and gPV fuse-link size 121 with blade contacts	1500	250 A	Open design, screw mounting	SP36121
NH fuse-links NH2XL and NH3L and gPV fuse-link size 122-123 with blade contacts	1500	630 A	Open design, screw mounting	SP36122-123
NH fuse-links NH1XL (can accept Mersen gPV fuse-links size 121 and NH2XL rated 250A with derating)	1500	250 A	With touch protection, screw mounting (M10, M = 8-10Nm)	HPBB1XL1PPFS
NH fuse-links NH2XL and NH3L	1500	500 A	With touch protection, screw mounting (M10, M = 8-10Nm)	HPBB2XL3L1PPFS
NH fuse-links NH2XL and NH3L (can accept NH3L fuse-links up to 630 A with derating)	1500	500 A	With touch protection, screw mounting (M10, M = 8-10Nm) and busbar output (1x40x10 or 2x40x10)	HPBB2XL3L1PBFS

HP15NH

1500VDC Size NH Photovoltaic Fuses

SPECIAL PURPOSE

FOR ARRAY PROTECTION



APPROVALS:

- UL listed to 2579
- IEC 60269-6 Certified, gPV
- RoHS Compliant



SP

Mersen's HeliProtection HP15NH photovoltaic (PV) fuse series is designed specifically for protection of PV string wiring for 1500VDC utility scale photovoltaic arrays. Low minimum breaking capacity of 1.35 times the fuse rated current value meets both IEC and UL standards, allowing for safe circuit interruption under typical low fault current conditions produced by PV arrays. Typical applications include DC re-combiner box, master DC combiner box, and array inverter inputs.

CATALOG NUMBERS AND ELECTRICAL CHARACTERISTICS

Voltage (VDC)	Amperage (A)	Catalog Number	Reference Number	Watts Loss @ 70% x In (W)	Watts Loss @ 100% x In (W)	Interrupting Rating (kA)	Size
1500	160	HP15NH3LGPV160B	T1048679	15	35	50	NH3L
	200	HP15NH3LGPV200B	V1048680	17	40		
	250	HP15NH3LGPV250B	W1048681	19	45		
	315	HP15NH3LGPV315B	X1048682	21	52		
	350	HP15NH3LGPV350B	Y1048683	23	56		
	400	HP15NH3LGPV400B	Z1048684	24	59		

CATALOG NUMBERS - FUSE BLOCKS

For use with	Voltage (VDC)	Amperage (A)	Terminal Type	Protective Cover	Catalog Number
NH3L	1500	500 max	Stud-Box	Yes	HPBB2XL3L1PBFS
			Stud-Stud	Yes	HPBB2XL3L1PPFS

DIMENSIONS

Special purpose gPV fuse link size 3L Direct Mounting without striker and without lugs

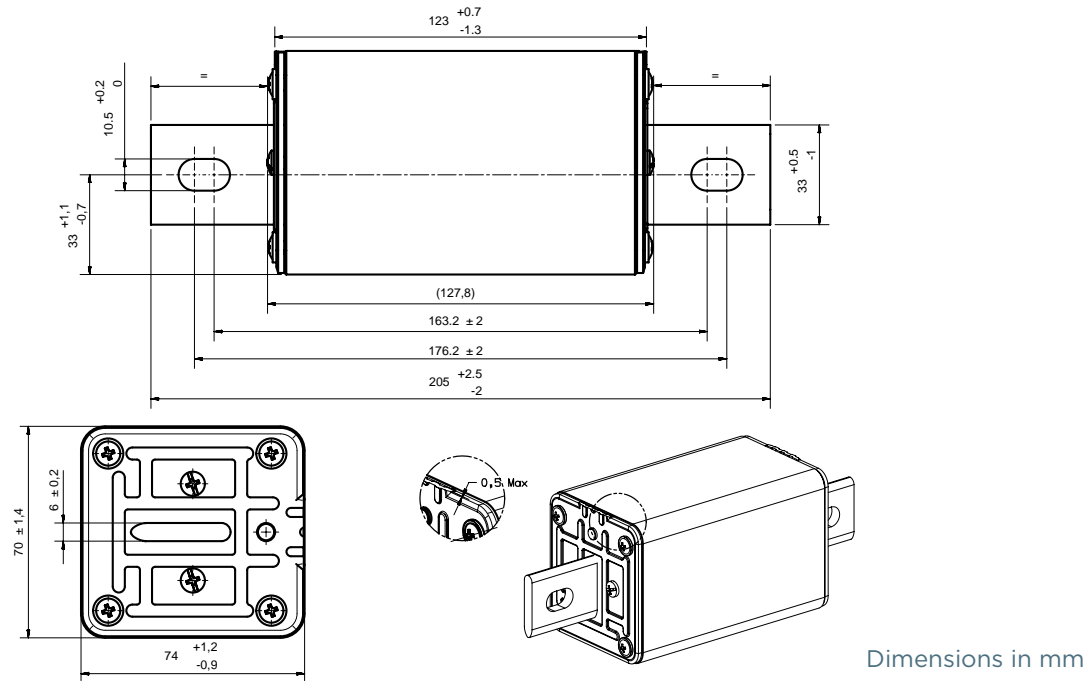

Special purpose gPV fuse link size 3L Direct Mounting with striker and without lugs

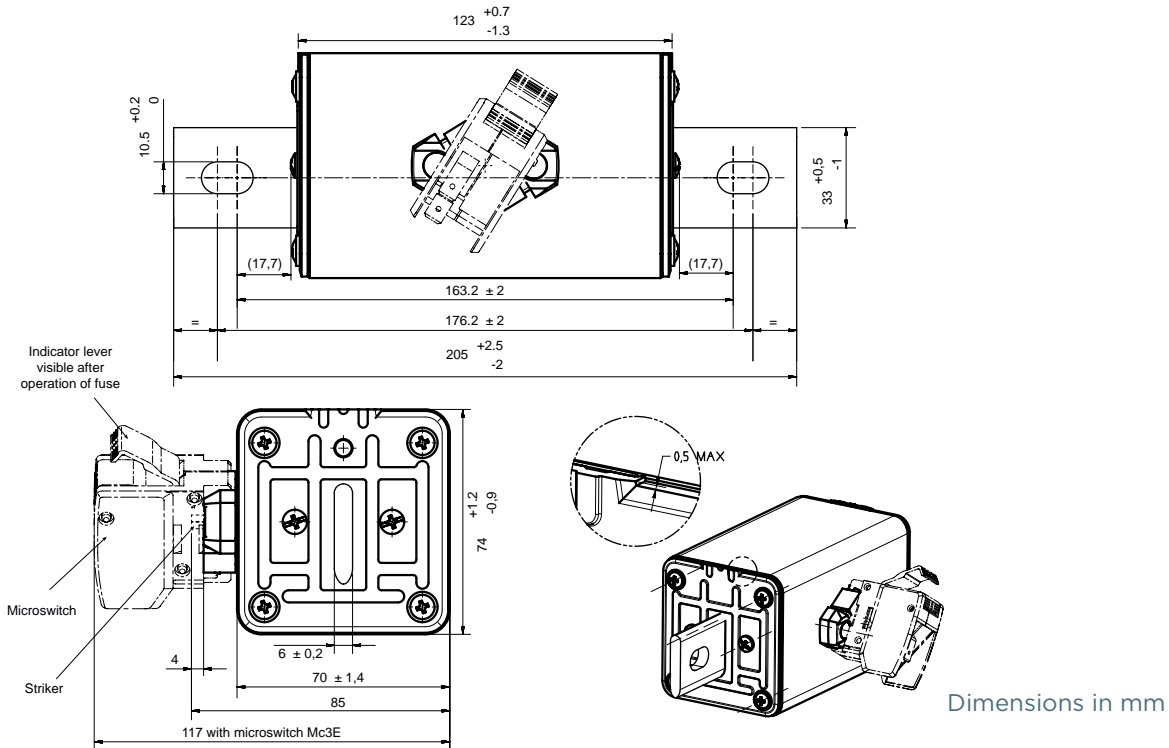

SP



Your problem: You need a range of standard fuse blocks to meet industrial requirements. You need DIN-rail mounting fuse holders that save space and conform with today's "Finger-safe" IEC standards. You need panel-mount fuse holders, blocks that safely handle stress on conductors, accessories to make pulling fuses safer.

Our solution: Mersen's extensive line of fuses is matched by our line of fuseblocks. Need a durable Class H, K, or R block? We've got configurations that accept nearly all 250 and 600V power fuses. How about Class CC or Class J IEC-style holders? Turn to our popular UltraSafe™ models for the small footprints, blown-fuse indicators, and finger-safe changeouts you want. The same goes for traditional Class J blocks, space-saving "SJ" blocks, 600V Class CC and midget dimension holders, and a dozen other fuse holder solutions.

Want more information fast? For more technical or application-specific information, please call our Fuse Block experts at 978-465-4853 or visit our website at ep.mersen.com.

Fuse Blocks & Holders

**YOU NAME
THE BLOCK, WE'VE
GOT IT IN STOCK**

UltraSafe™

- USCC & USM. FB 2
- USBB Bus Bar FB 4
- USGCC & USGM. FB 6
- USFM FB 8
- US3J & US6J. FB 10
- US14 & US22. FB 12

Open Style

- Class J & SJ Series FB 16
- Midget/Class CC FB 20
- Class H, K & R. FB 22
- Class T FB 29
- Class G. FB 34
- FEB/FEC/FEX/FEY. FB 36

Photovoltaic

- HPJ Class J FB 40
- US15M1HEL FB 42
- HP15FHM32. FB 43
- HPBB 1000V DC Size NH. FB 45

Medium Voltage

- Type EK 9F61 Series
Fuse Holders and Clips FB 46
- CL-14 Fuses Clip-Lock Clips FB 55

Semiconductor

- P243/P266/P292. FB 56
- 1SC/1MSC Modular FB 57
- 703, U705, U710 Series FB 58
- PS20x127 Ferrule FB 60

Miniature/Panel Mount

- Miniature Fuse Blocks. FB 62
- GPM Series Panel Mount FB 63

Covers/Clips

- DFC Dead Front
Fuse Covers FB 70
- DFC3M/DFC3LP/DRM
Fuse Block Accessories FB 72
- Ferrule Fuse Clips/
PC BoardMount Fuse Clips FB 73

**F
B**

USCC & USM

UltraSafe™ Fuse Holders

FUSE BLOCKS & HOLDERS

ULTRASAFE MODULAR FUSE HOLDERS FOR MIDGET AND CLASS CC FUSES



FB

Mersen UltraSafe Modular Fuse holders introduce a new level of safety for Class CC (USCC) and Midget 1-1/2" x 13/32" (USM) AC and DC-rated fuses up to 30 amperes. UltraSafe holders qualify as "Finger-safe" under IEC and DIN standards to an IP20 grade of protection, including fuse changing (with the flick of a finger). UltraSafe holders are available in 1, 2, 3 or 4 poles, with or without visual blown-fuse indicators in each pole. Multi-pole units can also be field assembled by ordering pin-tie handles.

UltraSafe holders save up to 15% mounting space and any combination can be snapped onto 35mm DIN-rail for extra savings in panel building time. UltraSafe holders with Class CC fuses chosen for Type "2" No Damage protection give one of the safest protection packages in the industry. UltraSafe body material is tough and durable polyamide, with exceptional insulating properties.

APPLICATIONS:

- All circuits up to 600 volts for motors, control circuits, transformers, etc...
- DC circuits up to 1000VDC including photovoltaic applications
- Non-load disconnect

RECOMMENDED FUSE USAGE:

- **USM use with:** ATQ, ATM*, A6Y-2B, A25Z-2, TRM, OTM, A13X-2, A60Q-2, DCT*, HP6M, HP10M
- **USCC use with:** ATDR, ATMR*, ATQR

* Recommended for DC applications

RATINGS:

USM (Midget 10x38mm Fuses)

- **Volts:** 800VAC Maximum, 1000VDC Maximum
- **Amps:** 30A Maximum
- **SCCR:** 200kA AC, 100kA DC

USCC (Class CC Fuses)

- **Volts:** 600VAC/DC Maximum
- **Amps:** 30A Maximum
- **SCCR:** 200kA

*Min. voltage to operate indicator light:
90VAC, 115VDC [Less than 0.7 mA leakage
current at 600V]*

*USM1HEL minimum indicator operating
voltage: 350VDC*

HIGHLIGHTS:

- IP20 Finger-Safe (touch safe)
- Optional visual blown fuse Indicator lights
- DIN-rail mounting
- Compact footprint
- Quick, tool-free, easy fuse change outs

APPROVALS:

- UL Listed to Standard 4248-4 (class CC) and 4248-1 (midget), File E52283
- UL Listed to standard 4248-18 (photovoltaic), File E347822
- CSA Certified C22.2
- IEC 60269-2-1 and 60947-3 Compliant (USM only)



ADDITIONAL SPECIFICATIONS:

- **Terminal screws:** Phillips/slot head
- **Suggested screw torque:** 14.75 in-lbs.
- **Wire range:** #14 to 6 AWG (2.5 to 16mm²) single conductor; #14 to 10 AWG (2.5 to 5.0 mm²) dual conductor
- **Wire type:** 60/75/90°C solid/stranded copper
- **Connector type:** Pressure plate
- **Load-break disconnect:** No
- **Environmental:** RoHS compliant, lead free
- **Operating temperature:** -40° to 85°C
- **Watts loss:** 3W or less
- **Flammability rating:** UL 94-V0
- **Optional Blown Fuse Indicator Lens Color:** Red

CATALOG NUMBERS:

Fuse Type	Ampere Rating	Voltage Rating		Visual Indication	No. of Poles	Catalog Number
		AC	DC			
Class CC	30	600	600	No	1	USCC1
	30	600	600	No	2	USCC2
	30	600	600	No	3	USCC3
	30	600	600	No	4	USCC4
	30	600	600	No	3+N	USCC3N
	30	600	600	Yes	1	USCC1I
	30	600	600	Yes	2	USCC2I
	30	600	600	Yes	3	USCC3I
	30	600	600	Yes	4	USCC4I
	30	600	600	Yes	3+N	USCC3IN
	30	120	-	Yes	1	USCC1I-AC120
	30	300	-	Yes	1	USCC1I-AC300
	30	-	24	Yes	1	USCC1I-DC24
Midget (10 x 38mm) (1-1/2" x 13/32")	30	800	1000	No	1	USM1
	30	800	1000	No	2	USM2
	30	800	1000	No	3	USM3
	30	800	1000	No	4	USM4
	30	800	1000	No	3+N	USM3N
	30	600	600	Yes	1	USM1I
	30	600	600	Yes	2	USM2I
	30	600	600	Yes	3	USM3I
	30	600	600	Yes	4	USM4I
	30	600	600	Yes	3+N	USM3IN
	30	120	-	Yes	1	USM1I-AC120
	30	-	24	Yes	1	USM1I-DC24
	Photovoltaic Midget	32	-	1000	No	1
32		-	1000	Yes	1	USM1IHEL

FB

IEC Ratings for USM: 690VAC / 1000VDC, 32A, 50kA SCCR

CSA Ratings for USM: 750VAC / 1000VDC, 30A

CATALOG NUMBERS—
ACCESSORIES:

Accessories Catalog No.	Description
USN	1-Pole with Integral Neutral Link
USPTH	Pin-tie Accessory for 12-Poles

DIMENSIONS

Dimension	mm	In	Dimension	mm	In
A	17.5	0.69	G	78.0	3.07
B	35.0	1.38	H	59.0	2.32
C	52.5	2.07	I	42.5	1.67
D	70.0	2.76	J	5.0	0.20
E	78.0	3.07	K	45.0	1.77
F	2.5	0.10			



USPTH Pin-Tie Accessory



USM1 with USPTH Pin-Ties

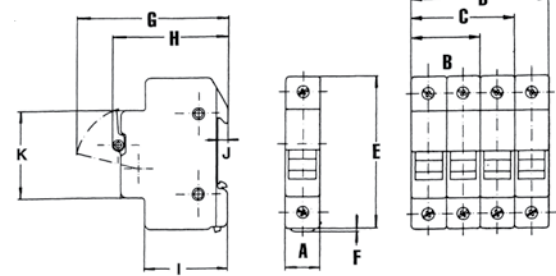

USBB

UltraSafe™ Bus Bar System

FUSE BLOCKS & HOLDERS

BUS BAR SYSTEMS FOR USE WITH ULTRASAFE CLASS CC (USCC) AND MIDGET (USM) FUSE HOLDERS



Mersen USBB UltraSafe bus bar systems are intended for use with UltraSafe Class CC (**USCC**) and Midget (**USM**) fuse holders. The USBB delivers safe and reliable combination of circuits in a compact design. Bus bar systems reduce installation time when compared to wire solutions, offer space savings and deliver touch-safe, shock resistant solutions to panel builders and designers. 1-, 2-, and 3-phase designs available.

CATALOG NUMBERS

BUS BAR (1-, 2-, AND 3-PHASE)					
Catalog No.	Phase	Poles	Cross Section	Pitch	Material
USBB1PH25K4	1	4	25mm ²	17.8mm	Copper
USBB1PH25K6		6			
USBB1PH25K8		8			
USBB1PH25K12		12			
USBB2PH25K4	2	4	25mm ²	17.8mm	Copper
USBB2PH25K6		6			
USBB2PH25K8		8			
USBB2PH25K10		10			
USBB3PH25K6	3	6	25mm ²	17.8mm	Copper
USBB3PH25K9		9			
USBB3PH25K12		12			
USBB3PH25K15		15			

FEEDER TERMINAL			
Catalog No.	Wire Range	Wire Type	Torque
USBBC1	10 - 1/0 AWG	60°C Cu	50 lb-in
USBBESB1**	14 - 1 AWG	75°C Cu	35 lb-in

** Requires dedicated space on bus bar

PROTECTIVE COVER	
Catalog No.	Qty per Unit
USBBPC	5
END CAPS	
Catalog No.	Qty per Unit
USBB1PHEC	1 set*
USBB23PHEC	1 pc

* 50 pc. minimum order quantity

RATINGS:

USBB Bus Bar

- **Volts:** 600VAC, 1000VDC
- **Amps:** 100A (End Feed), 200A (Center Feed)
- **SCCR:** 10kA, 100kA (with 200A J Fuse)

USBB Feeder Terminal

- **Volts:** 600VAC, 1000VDC
- **Amps:** 115A Maximum
- **SCCR:** 10kA, 100kA (with 200A J Fuse)

HIGHLIGHTS:

- Decrease installation time compared to wire solutions
- Save panel space with compact design and footprint
- Reduce shock hazards with touch-safe cover (included)
- Environmentally conscious, RoHS compliant and lead free
- Cuttable design offers flexibility

APPLICATIONS:

- UL 508 panels
- Solar string combiner boxes
- Control panels
- Power distribution panels

APPROVALS:

- UL Listed to Standard 508, File E348854
- IEC Compliant



FB

DIMENSIONS

1-PHASE BUS BAR - USBB1PH25K(4,6,8,12)

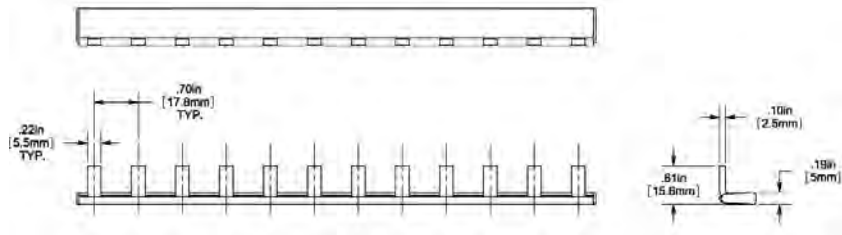

2-PHASE BUS BAR - USBB2PH25K(4,6,8,10)

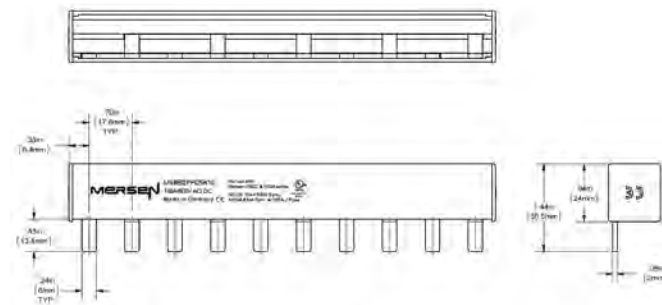

3-PHASE BUS BAR - USBB3PH25K(6,9,12,15)

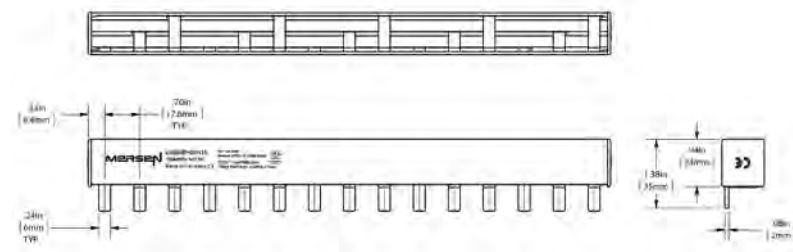

USBBC1	USBESB1**	USBBC	USB1PHEC	USB23PHEC

** Requires dedicated space on bus bar

FB

USGCC & USGM

UltraSafe™ Fuse Holders

FUSE BLOCKS & HOLDERS

INNOVATIVE ULTRASAFE CLASS CC AND MIDGET FUSE HOLDERS WITH SCREW-LESS, SPRING PRESSURE, WIRE TERMINATION TECHNOLOGY



Mersen's USGCC & USGM series fuse holders deliver the ultimate ease-of-use, time (labor) saving and reliable solution available in the marketplace. Mersen is the first manufacturer to offer screw-less, spring pressure, wire termination technology into a power fuse holder, delivering the best of both technologies to its customers. Now you can experience the combined benefits of safety, ease-of-use, labor savings and reliability of UltraSafe fuse holders and spring pressure technology.

HIGHLIGHTS:

- Equipped with industry proven, patented WAGO CAGE CLAMP® technology (over 25 years of field experience and acceptance)
- Reduce wire installation time by up to 75%
- Highly reliable, maintenance free wire contact
- Secure, vibration proof, corrosion resistant, temperature cycling resistant, cost saving wire connection
- Quick, tool-free, easy fuse change-outs
- IP20 finger-safe protection
- Option visual blown fuse indicator
- DIN-rail mounting
- Compact footprint
- Environmentally conscious, RoHS compliant and lead free

RECOMMENDED FUSE USAGE:

- **USGM** use with Midget Fuses: ATQ, ATM, TRM, OTM, A60Q-2, DCT-2
- **USGCC** use with Class CC Fuses: ATDR, ATQR, ATMR
- **USGM-HEL** use with Photovoltaic Fuses: HP6M, HP10M

RATINGS:

USGM (Midget 10x38mm Fuses)

- **Volts:** 750VAC maximum
: 1000VDC maximum
- **Amps:** 30A maximum
- **SCCR:** 200kA AC, 100kA DC

USGCC (Class CC Fuses)

- **Volts:** 600VAC/DC maximum
- **Amps:** 30A maximum
- **SCCR:** 200kA

*Min voltage to operate indicator light:
90VAC, 115VDC [Less than 0.7 mA leakage
current at 600V]*

*USGM1IHEL minimum indicator operating
voltage: 350VDC*

APPLICATIONS:

- All circuits up to 750VAC / 1000VDC for power control, power distribution and power electronics
- Non-load disconnect

APPROVALS:

- UL Listed to Standard 4248-4 (Class CC) and 4248-1 (Midget), File E52283
- UL Listed to Standard 4248-18 (Photovoltaic), File E347822
- CSA Certified C22.2
- IEC Compliant (USGM only)



ADDITIONAL SPECIFICATIONS:

- Screw-less, spring pressure terminals: WAGO CAGE CLAMP®
- Wire Range: #14 to 6 AWG (2.5 to 16mm²) Single Conductor; #14 to 10 AWG (2.5 to 5.0 mm²) Dual Conductor
- Wire Type: 60/75/90°C Solid/Stranded Copper; Can be used with wire ferrules
- Wire Strip Length: 12-13 mm (0.49 in)
- Load-Break Disconnect: No
- Environmental: RoHS compliant, Lead Free
- Operating Temperature: -40 to +85°C
- Watts Loss: 3W or less
- Flammability Rating: UL 94-V0
- Optional Blown Fuse Indicator Lens Color: Red

CATALOG NUMBERS

Fuse Type	Ampere Rating	Voltage Rating		Visual Indication	No. of Poles	Catalog Number
		AC	DC			
Class CC	30	600	600	No	1	USGCC1
	30	600	600	No	2	USGCC2
	30	600	600	No	3	USGCC3
	30	600	600	No	4	USGCC4
	30	600	600	No	3 + N	USGCC3N
	30	600	600	Yes	1	USGCC1I
	30	600	600	Yes	2	USGCC2I
	30	600	600	Yes	3	USGCC3I
	30	600	600	Yes	4	USGCC4I
	30	600	600	Yes	3 + N	USGCC3IN
Midget [10 x 38mm] [1-1/2" x 13/32"]	30	750	1000	No	1	USGM1
	30	750	1000	No	2	USGM2
	30	750	1000	No	3	USGM3
	30	750	1000	No	4	USGM4
	30	750	1000	No	3 + N	USGM3N
	30	600	600	Yes	1	USGM1I
	30	600	600	Yes	2	USGM2I
	30	600	600	Yes	3	USGM3I
	30	600	600	Yes	4	USGM4I
	30	600	600	Yes	3 + N	USGM3IN
Photovoltaic Midget	32	-	1000	No	1	USGM1HEL
	32	-	1000	Yes	1	USGM1HEL



Continuous marking strip and adaptors



WMB Marker System

FB

DIMENSIONS

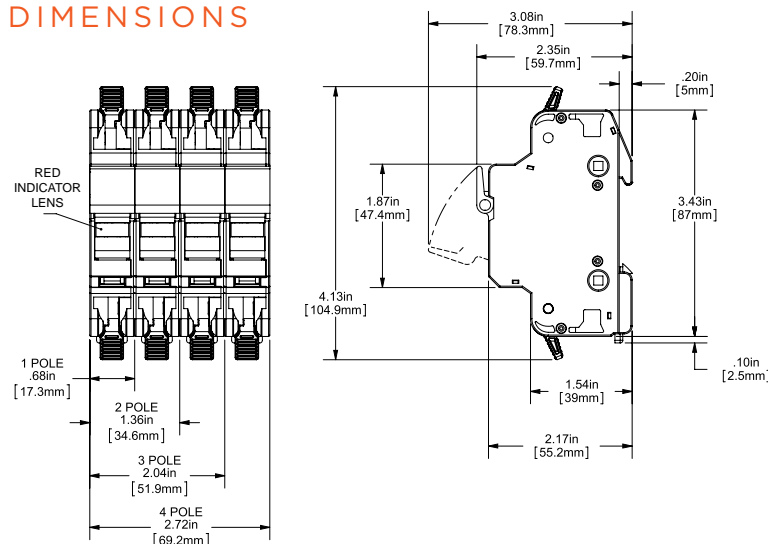

CATALOG NUMBERS - ACCESSORIES

Catalog No.	Description
USGN	1-Pole with Integral Neutral Link
USPTH	Pin-Tie Accessory for 12-Poles
USTP	Test Plug, 2 x 500mm (0.079 x 17.7 in), Red
USWMB0	WMB Markers, blank, 10 x 10 strips
USWMB1	WMB Markers, pre-marked 1-10, x10 strips
USCMA	Continuous Marking Strip Adapter (1 needed per pole)
USCM0*	Continuous Marking Strips, blank, 10 x 10 strips
USCM1*	Continuous Marking Strips, pre-marked 1-10, x10 strips

* USCMA required for use with USCM0 and USCM1

USFM

UltraSafe™ Fuse Modules

FUSE BLOCKS & HOLDERS

ULTRASAFE 3-POLE FUSE MODULES FOR MIDGET AND CLASS CC FUSES



Mersen UltraSafe™ Fuse Modules have a unique, compact design suited for use with 45mm wide IEC contactors. These modules also offer other features not found on other Class CC and midget UltraSafe fuse holders such as an auxiliary contact option. When the auxiliary is wired to an adjacent contactor the load is dropped out by the contactor immediately once someone tries to open the fuse extractor handle. Additionally, the fuse module features padlock capabilities, compact busbars for line side terminations, and tool free removal from DIN-rail. Yet the fuse modules still incorporate well known UltraSafe features such as IP20 protection, easy operating fuse extraction handles and an open fuse visual indication option.

HIGHLIGHTS:

- Dedicated 3-pole fuse module
- Finger-safe
- Compact footprint with 45mm width
- Auxiliary contact option (1NO/1NC)
- Ability to padlock in OPEN position with 1/4" shank diameter
- DIN-rail mount with tool free removal
- Quick, easy fuse change
- Optional indicator lights

APPLICATIONS:

- Primarily for motor circuits to replace circuit breakers for higher SCCR ratings
- Other circuits up to 600 volts for control circuits, transformers, etc.
- Non-load disconnect
- Padlock compliance



RATINGS:

USFMCC (Class CC Fuses)

- **Volts:** 600VAC / DC
- **Amps:** 30A Maximum
- **SCCR:** 200kA

USFM10 (Midget 10x38mm Fuses)

- **Volts:** 600VAC / DC
- **Amps:** 30A Maximum
- **SCCR:** 100kA

Min. voltage to operate indicator light: 90VAC, 115VDC [Less than 0.7 mA leakage current at 600V]

RECOMMENDED FUSE USAGE:

- USM use with: ATQ, ATM*, A6Y-2B, A25Z-2, TRM, OTM, A13X-2, A60Q-2, DCT*
- USCC use with: ATDR, ATMR*, ATQR
* Recommended for DC applications

APPROVALS:

USFMCC (Class CC Fuses)

- UL Listed, guide IZLT, File E52283
- CSA Certified C22.2, class 6225 01, File 32169

USFM10 (Midget 10x38mm Fuses)

- UL Recognized Component, guide IZLT2, File E52283
- CSA Certified C22.2, Class 6225 01, File 32169
- IEC Certified 60269-1, 60947-3 (690VAC, 32A, 120kA)

CATALOG NUMBERS AND DESCRIPTIONS:
FOR USE WITH CLASS CC FUSES

Catalog No.	Description
USFMCC	3 pole fuse module
USFMCCI	3 pole fuse module with indicators
USFMCCM	3 pole fuse module with microswitch style auxiliary contact
USFMCCMI	3 pole fuse module with microswitch style auxiliary contact and indicators



USFMAC11

FOR USE WITH MIDGET AND 10X38MM
UL AND IEC FUSES

Catalog No.	Description
USFM10	3 pole fuse module
USFM10I	3 pole fuse module with indicators
USFM10M	3 pole fuse module with microswitch style auxiliary contact
USFM10MI	3 pole fuse module with microswitch style auxiliary contact and indicators



USFMBB2

ACCESSORIES

Catalog No.	Description
USFMAC11	1NO (late make)/NC (early break) auxiliary contact
USFMBB2	Bus bar to connect 2 modules together
USFMBB3	Bus bar to connect 3 modules together
USFMBB4	Bus bar to connect 4 modules together
USFMBB5	Bus bar to connect 5 modules together
USFMBBC1	Bus bar connector terminal



USFMBBC1

DIMENSIONS

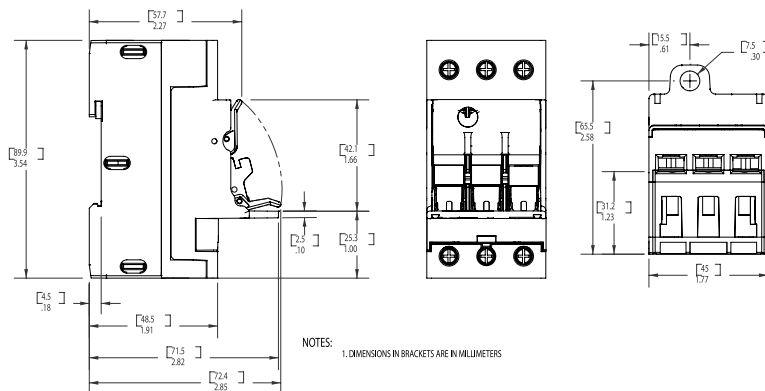

ADDITIONAL SPECIFICATIONS:

- Terminal screws: Pozidriv#2
- Suggested screw torque: 13 Lbs-in (1.5 N-m)
- Connector type: Pressure plate
- Wire range: #10 to #16 AWG (1-4 mm²)
- 75°C solid/stranded Cu only
- Load-break disconnect: No (when auxiliary contact is installed in fuse module and properly wired to adjacent IEC contactor the load will be dropped out prior to disconnection between fuse and clip inside holder upon operation of the fuse extractor handle).

FB

US3J & US6J

UltraSafe™ Class J Fuse Holders

FUSE BLOCKS & HOLDERS

ULTRASAFE™ MODULAR FUSE HOLDERS FOR CLASS J FUSES



Mersen UltraSafe Modular 600 Volt Fuse Holders for Class J fuses introduce a new level of safety and ease for installing or replacing Class J fuses. UltraSafe holders qualify as “finger-safe” to an IP20 grade of protection under IEC standards. The US3J accommodates 30A Class J or 22 x 58 mm French Ferrule* fuses. The US6J is for 60A Class J fuses. UltraSafe holders are available in compact 1, 2, or 3 pole units, with or without blown-fuse indicators in each pole. Multi-pole units can also be made up in the field by using the multiple-pole Assembly Kits. All units have provisions for locking in the open position for safety during fuse changeouts or equipment servicing. US3J and US6J holders can be snap-mounted to 35 mm DIN-rail and they have a unique latch which will stay open to allow re-positioning of the holder in the future. UltraSafe body material is tough and durable polyamide.

**Holder not UL listed when installed with French Ferrule fuses.*

RECOMMENDED FUSE USAGE:

US3J, US6J use with AJT, A4J, HSJ

RATINGS:

- **Volts:** 600VAC/DC
- **Amps:** US3J - 30A Maximum, US6J - 60A Maximum
- **SCCR:** 200kA

*Min. voltage to operate indicator light:
90VAC, 115VDC [Less than 0.7 mA leakage
current at 600V]*

HIGHLIGHTS

- Finger-safe IP20 protection
- Optional indicator lights
- DIN-rail mount
- Compact footprint
- Quick, easy fuse change

APPLICATIONS:

- 600 volt motors, transformers, lighting, heating, control circuits, general loads
- Non-load disconnect

APPROVALS:

- UL Listed, guide IZLT File E52283
- CSA Certified C22.2, class 6225 01, File 32169
- IEC certified 60269-1, 60947-3



CATALOG NUMBERS

Catalog No. W/O Indicator	Catalog No. W/ Indicator	Description	Fuse Type	Voltage Rating		Ampere Rating	No. of Poles	Certifications
				AC	DC			
US3J1	US3J1I	1-Pole 30A Class J UltraSafe Fuse Holder	Class J	600V	600V	30A	1	UL Listed CSA Approved IEC Certified
US3J2	US3J2I	2-Pole 30A Class J UltraSafe Fuse Holder					2	
US3J3	US3J3I	3-Pole 30A Class J UltraSafe Fuse Holder					3	
US6J1	US6J1I	1-Pole 60A Class J UltraSafe Fuse Holder				60A	1	
US6J2	US6J2I	2-Pole 60A Class J UltraSafe Fuse Holder					2	
US6J3	US6J3I	3-Pole 60A Class J UltraSafe Fuse Holder					3	

CATALOG NUMBERS -
ACCESSORIES

Accessories Catalog No.	Description
US3JN	1-Pole Neutral 30A Class J UltraSafe Fuse Holder
US3JPAK	Pin Tie Assembly Kit, 6-Poles, for use with US3J
US6JN	1-Pole Neutral 60A Class J UltraSafe Fuse Holder
US6JPAK	Pin Tie Assembly Kit, 6-Poles, for use with US6J

DIMENSIONS

Dimension	US3J		US6J	
	mm	In	mm	In
A	32.5	1.28	40	1.57
B	65	2.56	80	3.15
C	97.5	3.84	120	4.72
E	114	4.49	122	4.80
F	3	0.12	3	0.12
G	106	4.17	115	4.53
H	80	3.15	89	3.50
I	56	2.20	62	2.44
J	6.5	0.26	6.5	0.26

ADDITIONAL SPECIFICATIONS:

Terminal screws: Phillips/slot head

Suggested screw torque: 30A - 35 in-lbs.
60A - 45 in-lbs.

Connector type: Pressure plate

Wire range: #2 to #14 (solid/stranded Cu)

Load-break disconnect: No

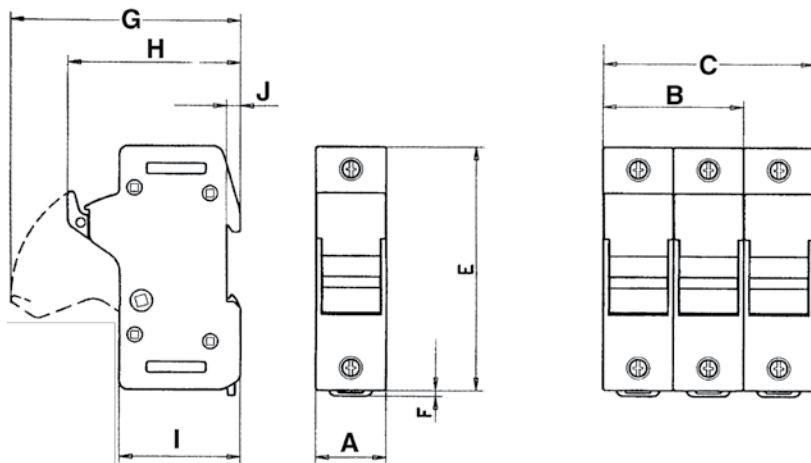

FB

US14 & US22

750 Volt UltraSafe™ Fuse Holders

FUSE BLOCKS & HOLDERS

ULTRASAFE MODULAR FUSE HOLDERS FOR 14 X 51 AND 22 X 58MM FUSES



Mersen UltraSafe™ modular 750 volt Fuse Holders offer the highest levels of safety and features for 14 x 51 mm and 22 x 58 mm fuses. Like all UltraSafe holders, they qualify as “finger-safe” to an IP20 grade of protection under IEC standards, including fuse changing (with the flick of a finger). The US14 and US22 ranges are available in 1, 2 or 3 pole units, with or without blown-fuse indicator lights in each pole.

These holders come standard with a mechanical indicator that shows fuse presence. If a striker fuse is used, this mechanical indicator will also indicate a blown fuse. Microswitches can be supplied with the holders (or ordered separately for field installation) to allow remote communication. These holders also feature padlocking capabilities, DIN-rail mounting with our unique latching system to allow re-positioning, and the capability to be joined as multiple poles in the field.

RECOMMENDED FUSE USAGE:

- US14 use with 14 x 51mm: A70QS, A70P, URC, URD
- US22 use with 22 x 58 mm: A70QS, URD

RATINGS:

- **Volts:** 750VAC/DC
- **Amps:** 50A (14 x 51 mm), 125A (22 x 58 mm)
- **SCCR:** 200kA

HIGHLIGHTS:

- Finger-safe
- Optional indicator lights
- Optional microswitches
- DIN-rail mount
- Compact footprint
- Quick, easy fuse change

APPLICATIONS:

- All circuits up to 750 volts using semiconductor fuses for protection of small inverters, UPS systems, motor drives, etc.
- No-load disconnect
- IP20 requirements

APPROVALS:

- All UltraSafe fuse holders meet the requirements of UL4248
- UL Recognized Component guide IZLT2, File E52283
- CSA Certified C22.2, class 6225, File 32169
- IEC Compliant (60269-1, 60947-3)



CATALOG NUMBERS AND
DESCRIPTIONS -

FOR USE WITH 14 X 51 MM
FUSES UP TO 50A

Reference No.	Catalog No.	Description
Z331153	US141	1 Pole
G331137	US142	2 Pole
N331143	US143	3 Pole
A331154	US141I	1 Pole with Indicator
H331138	US142I	2 Pole with Indicators
P331144	US143I	3 Pole with Indicators
B331155	US141M	1 Pole with Microswitch
J331139	US142M	2 Pole with Microswitch
Q331145	US143M	3 Pole with Microswitch
L331141	US142M2	2 Pole with 2 Microswitches
T331148	US143M2	3 Pole with 2 Microswitches
C331156	US141MI	1 Pole with Microswitch & Indicator
K331140	US142MI	2 Pole with Microswitch & Indicator
S331147	US143MI	3 Pole with Microswitch & Indicator
M331142	US142M2I	2 Pole with 2 Microswitches & Indicators
W331150	US143M2I	3 Pole with 2 Microswitches & Indicators
D331157	US141N	1 Pole - Neutral
X331151	US143N	3 Pole - Neutral
R227922	US143NI	3 Pole - Neutral Conductor and Indicator
Y331152	US143NM	3 Pole - Neutral Conductor and Microswitch
X227927	US14PAK	Accessory - Multi-pole Assembly Kit
Y227928	US14S1P	Accessory - 1 Pole Microswitch
Z227929	US14S3P	Accessory - 3 Pole Microswitch
A227930	US14S3P2	Accessory - 3 Pole, 2 Microswitches

CATALOG NUMBERS AND
DESCRIPTIONS -

FOR USE WITH 22 X 58 MM
FUSES UP TO 125A

Reference No.	Catalog No.	Description
E331158	US221	1 Pole
K331163	US222	2 Pole
R331169	US223	3 Pole
F331159	US221I	1 Pole with Indicator
L331164	US222I	2 Pole with Indicators
S331170	US223I	3 Pole with Indicators
G331160	US221M	1 Pole with Microswitch
M331165	US222M	2 Pole with Microswitch
T331171	US223M	3 Pole with Microswitch
P331167	US222M2	2 Pole with 2 Microswitches
W331173	US223M2	3 Pole with 2 Microswitches
Z1006203	US221MI	1 Pole with Microswitch & Indicator
N331166	US222MI	2 Pole with Microswitch & Indicators
V331172	US223MI	3 Pole with Microswitch & Indicators
Q331168	US222M2I	2 Pole with 2 Microswitches & Indicators
X1011974	US223M2I	3 Pole with 2 Microswitches & Indicators
H331161	US221N	1 Pole - Neutral
X331174	US223N	3 Pole - Neutral
J331162	US221NM	1 Pole - Neutral Conductor and Microswitch
B227931	US22N	1 Pole - Neutral
F227958	US22PAK	Accessory - Multi-pole Assembly Kit
G227959	US22S1P	Accessory - 1 Pole Microswitch
B331201	US22S3P	Accessory - 3 Pole Microswitch
J227961	US22S3P2	Accessory - 3 Pole, 2 Microswitches

DIMENSIONS

Dimension	US14		US22	
	mm	In	mm	In
A	26.5	1.04	35.0	1.38
B	53.0	2.09	70.0	2.76
C	79.5	3.13	105.0	4.13
E	107.0	4.21	124.0	4.88
F	3.80	0.15	3.80	0.15
G	94.0	3.70	103.0	4.06
H	76.5	3.01	76.5	3.01
I	50.5	1.98	50.5	1.98
J	6.50	0.26	6.5	0.26
K	45.0	1.77	45.0	1.77

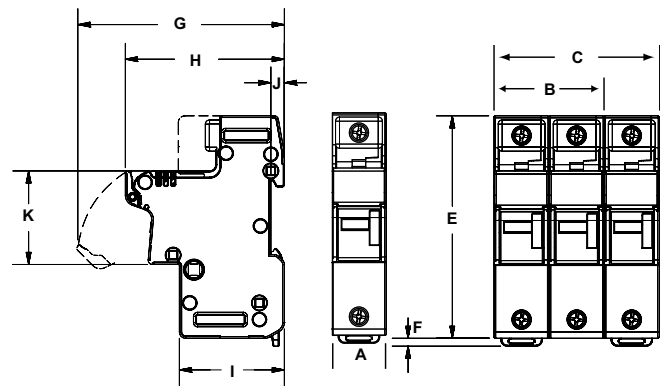

ADDITIONAL SPECIFICATIONS:

Terminal screws: Phillips/slot head

Suggested screw torque: 50A - 35 lbs.-in. 125A - 45 lbs.-in.

Connector type: Pressure Plate

Wire range: US14 #2 to #14 (solid/stranded Cu), US22 1/0 to #14 (solid/stranded Cu)

Load-break disconnect: No

FB

Lock installation

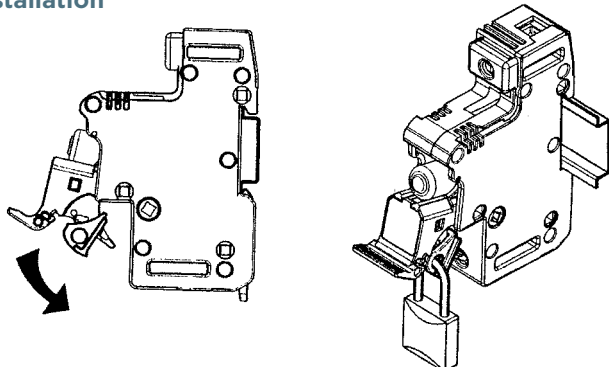

Microswitch mounting instructions(*)

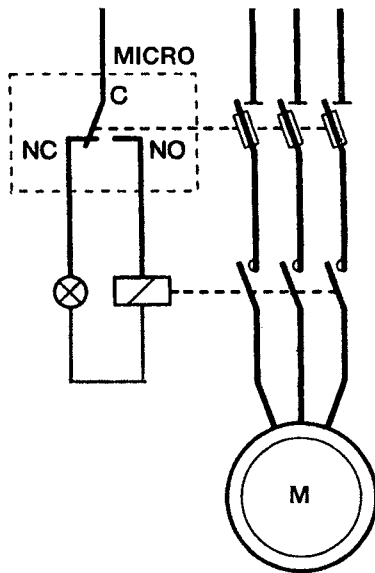

Assembly

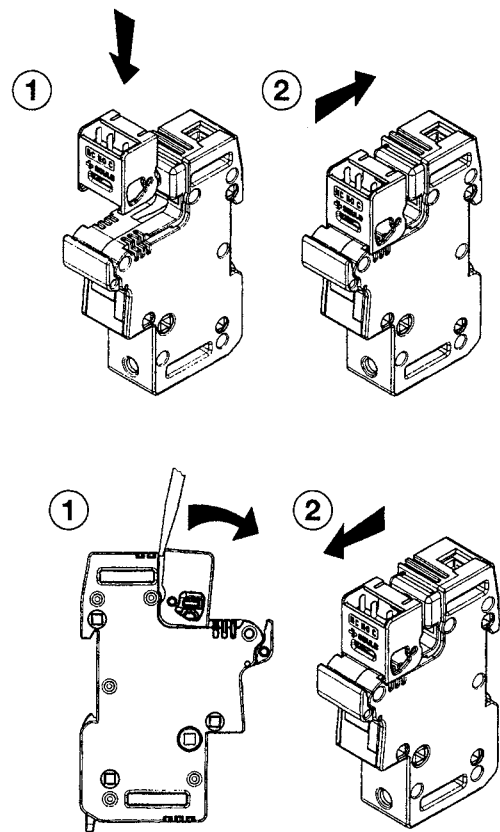

AUXILLIARY MICROSWITCH CHARACTERISTICS

(*) Microswitch functions

Blown fuse:	Fuse holder containing fuse with striker sends message when fuse blown	Nominal current and interrupting rating(1) at 250V	6A 3A	AC12 AC13 0,3A AC14
Prebreaking:	When fuse holder opens	Nominal current and interrupting rating(1) at 12 V and 24 V	0,1A 6A	DC12/13/14 DC12/DC13
Presence:	Sends message or not depending on fuse presence		5A 2A 0,6A	AC13 AC14/DC13 DC14

(1) According IEC947-5 Standard

Microswitch options

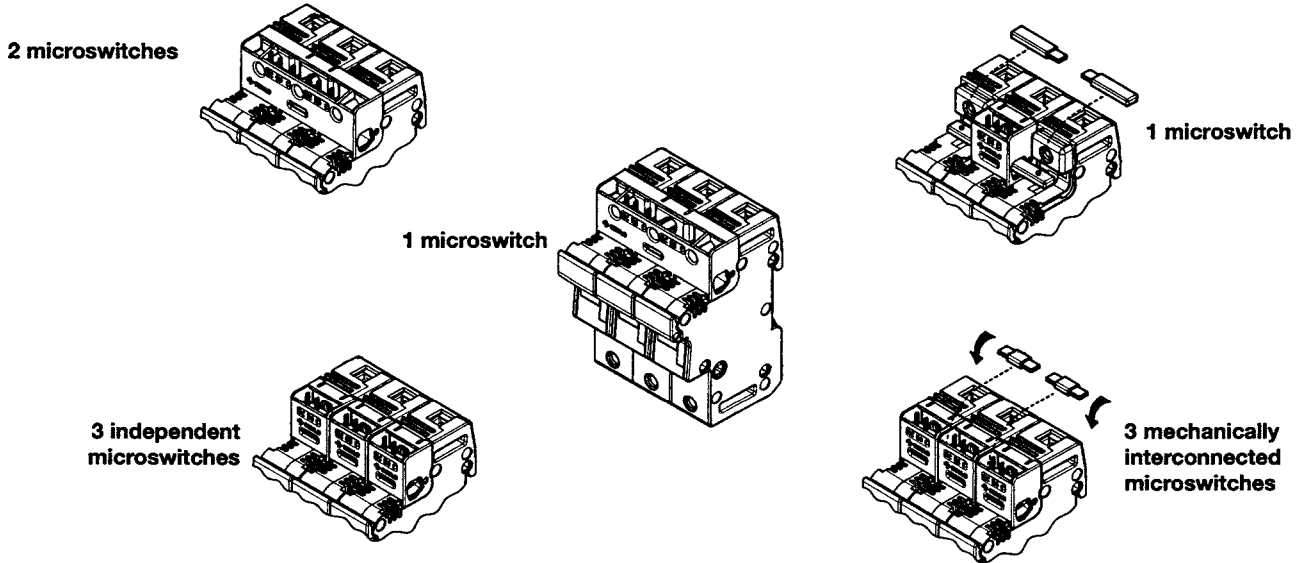

Fuse holder assembly

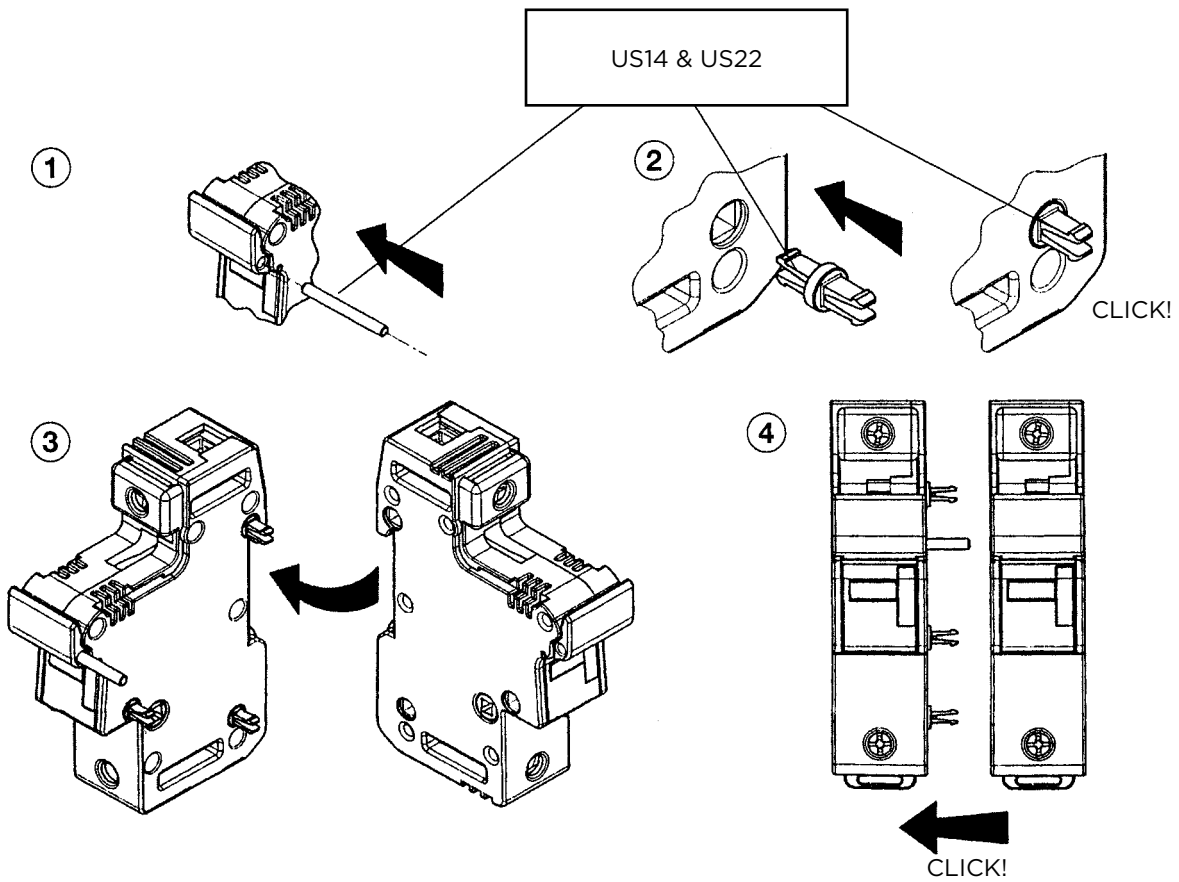

FB

Class J

600 Volt Fuse Blocks

FUSE BLOCKS & HOLDERS















MERSEN CLASS J FUSE BLOCKS ACCOMMODATE ALL CLASS J FUSES



FB

A choice of screw, pressure plate, box and special order stud connectors fit a wide range of stranded or solid copper or aluminum conductors. Insulators are either molded glass-filled polycarbonate (GFPC) or phenolic with verified dielectric strength in excess of 2500V. 30A, 60A and the new 100A SJ fuse blocks feature a unique adder block configuration which can be snapped onto 1-, 2-, or 3-pole blocks to form multi-pole segmented blocks of as many poles as desired. All fuse clips are made of high conductivity tin-plated copper, with a choice of spring-reinforced or non-spring reinforced clips. Space saving options are now available in the 30A and 100A configurations which are noted in the product selection tables.

CLIP & CONNECTOR TYPES:

30A & 60A Clips	Connectors	Connectors	Connectors	Connectors
Spring Reinforced 	Non-spring Reinforced 30A & 60A Box 	Spring Reinforced 30A & 60A Box 	Spring Reinforced 100A Box 	Spring Reinforced 400A Box Side Clip 
Non-spring Reinforced 	Non-spring Reinforced 30A Screw 	Spring Reinforced 30A Screw 	Spring Reinforced 100A Box Side Clip 	Spring Reinforced 400A Box In-line Clip 
	Non-spring Reinforced 30A Pressure Plate 	Spring Reinforced 30A Pressure Plate 	Spring Reinforced 200A Box Side Clip 	Spring Reinforced 600A Box In-line Clip 

RATINGS:

- **Volts:** 600VAC/DC
- **Amps:** 30A, 60A, 100A; 200A, 400A, 600A
- **SCCR:** 200kA

RECOMMENDED FUSE USAGE:

- Class J Blocks (600V) use with AJT, A4J, HSJ

APPROVALS:

- All class J fuse blocks meet the requirements of UL4248 (formerly UL512)
- UL listed Guide IZLT, File E52283
- CSA certified class 6225, File 32169



600 VOLT, 30 & 60 AMPERE CLASS J FUSE BLOCKS

Ampere Rating	Poles	Connectors		Catalog Number		Connector Torque In - lb
		Types	Wire Range	Non-Spring Reinforced	Spring Reinforced	
30 GFPC Insulator	ADDER	BOX	Al/Cu #2-14	60300J	60305SJ	35
	1			60301J	60306SJ	
	2			60302J	60307SJ	
	3			60303J	60308SJ	
	ADDER	SCREW	Cu* #4-14	60310J	60315SJ	20
	1			60311J	60316SJ	
	2			60312J	60317SJ	
	3			60313J	60318SJ	
	ADDER	PRESSURE PLATE	Cu* #4-14	60320J	60325SJ	20
	1			60321J	60326SJ	
	2			60322J	60327SJ	
	ADDER	BOX	Cu* #4-14	-	60355SJ	35
	1			-	60356SJ	
	2			-	60357SJ	
	3			-	60358SJ	
60 GFPC Insulator	ADDER	BOX	Al/Cu #2-14	60600J	60605J	45
	1			60601J	60606J	
	2			60602J	60607J	
	3			60603J	60608J	
	ADDER	BOX	Cu* #4-14	-	60655J	45
	1			-	60656J	
	2			-	60657J	
	3	-	60658J			

Note: To convert 30A "SJ" adder pole to single pole use end barrier cat # U09372. To convert 30A or 60A standard J adder pole to single use pole use end barrier cat # U09617. Recommended mounting screws for all 30A and 60A fuse blocks: 1/4" (0.250" dia).

*Fuses have copper box connectors and clips and are for copper wires only. These are specifically designed with the same coefficient of expansion as copper wire for improved heat cycling and meet or exceed OEM "no aluminum" specifications.

DIMENSIONS FOR 30A SPACE SAVING "SJ" STYLE FUSE BLOCKS

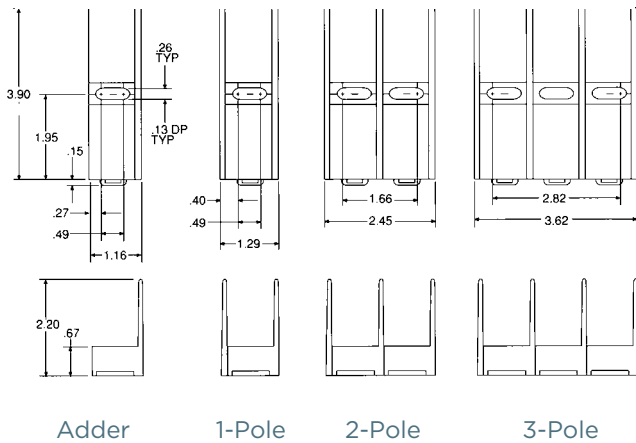

DIMENSIONS FOR 30A AND 60A STANDARD CLASS J STYLE FUSE BLOCKS

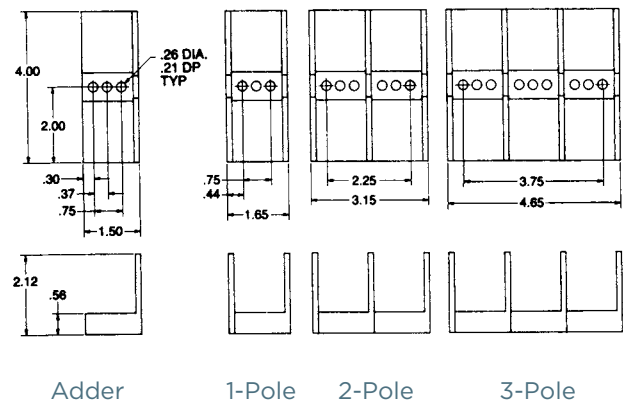

FB

600 VOLT, 100 AMPERE CLASS J FUSE BLOCKS

Ampere Rating	Poles	Connectors		Catalog Number	Connector Torque In - lb
		Type	Wire Range	Spring Reinforced	
100 GFCP Insulator	Adder 1 2 3	Box Side Clip	Al/Cu 2/0-#6	61005SJ	100 (Al) 60 (Cu)
				61006SJ	
				61007SJ 61008SJ	
	1 2 3	Box	Al/Cu 2/0-#6	61036J	120
				61037J	
				61038J	
	1 2 3	Box	Cu* 2/0-#12	61006J	50
				61007J	
				61008J	

DIMENSIONS FOR 100A SPACE SAVING "SJ" STYLE FUSE BLOCKS

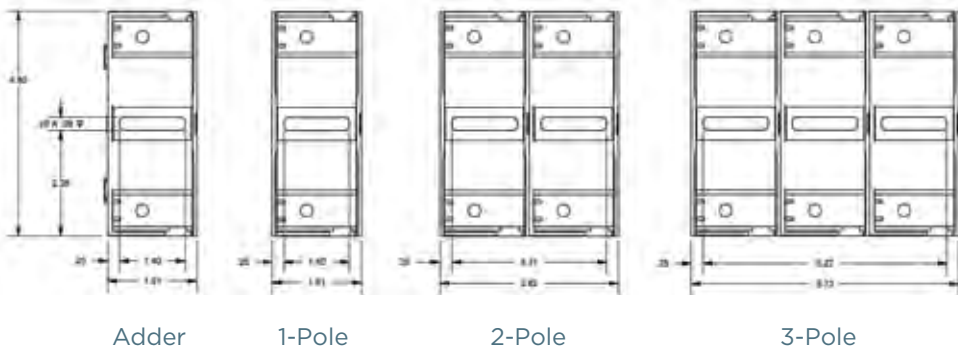

FB

DIMENSIONS FOR 100A STANDARD CLASS J STYLE FUSE BLOCKS

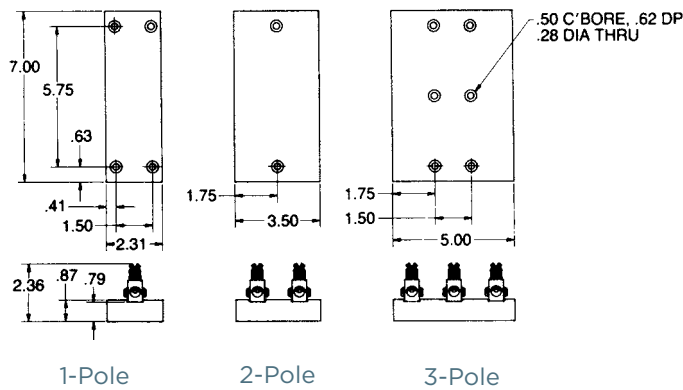

600 VOLT, 200, 400 & 600 AMPERE CLASS J FUSE BLOCKS

Ampere Rating	Poles	Connector		Catalog No.	Fig.	Connector Torque In - lb
		Type	Wire Range			
200 Phenolic Insulator	1	Box	Al/Cu	62001J	1	375
	3	Side-Clip	350kcmil-#6	62003J	2	
	1	Box	Cu**	62051J	1	275
	3	Side-Clip	350kcmil-#6	62053J	2	
400 Phenolic Insulator	1	Box*	AL/Cu	64001J	3	375
	3	Side-Clip	1000-250kcmil	64003J	4	
	1	Box	AL/Cu	64031J	5	275
	3	In-Line Clip	{2} 350kcmil-#4	64033J	6	
	1	Box*	Cu**	64051J	3	375
	3	Side-Clip	1000-250kcmil	64053J	4	
	1	Box	Cu**	64061J	5	275
	3	In-Line Clip	{2} 350kcmil-#6	64063J	6	
600 Phenolic Insulator	1	Box	Al/Cu	6631J	7	500
	3	In-Line Clip	{2} 500kcmil-#4	6633J	8	
	1	Box	Cu**	6661J	7	375
	3	In-Line Clip	{2} 500kcmil-#4	6663J	8	

* Not UL Listed or CSA Certified

** Fuse blocks have copper box connectors and clips and are for copper wires only. These are specifically designed with the same coefficient of expansion as copper wire for improved heat cycling and meet or exceed OEM "no aluminum" specifications.

Recommended mounting screws:
All 200A, 400A & 600A - 5/16" (.313" dia.)

DIMENSIONS

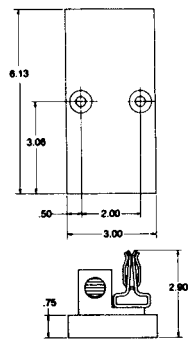

Figure 1

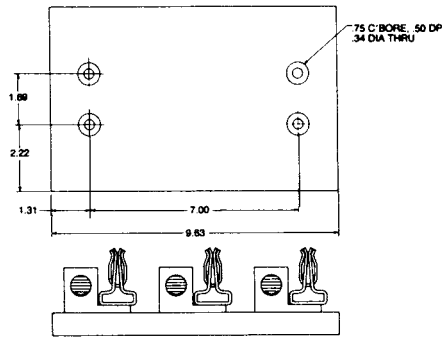

Figure 2

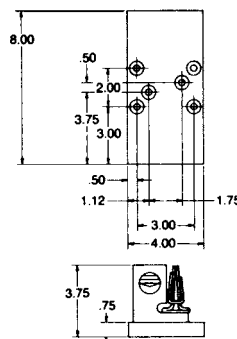

Figure 3

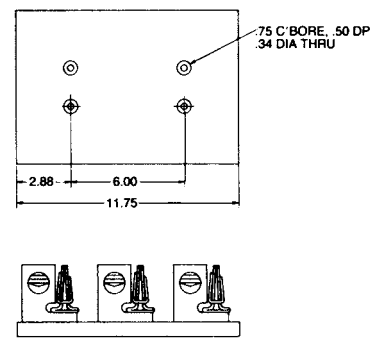

Figure 4

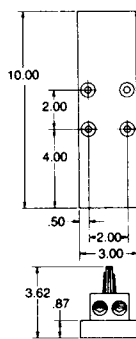

Figure 5

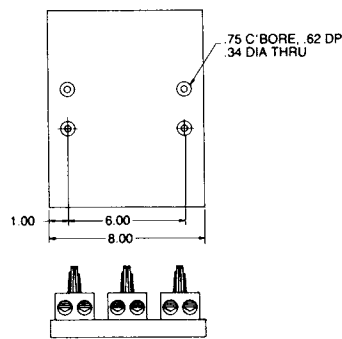

Figure 6

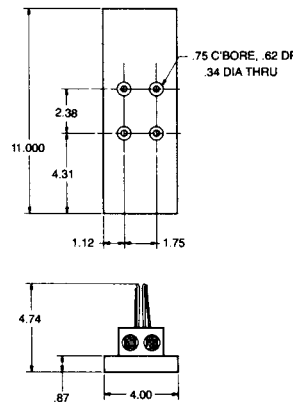

Figure 7

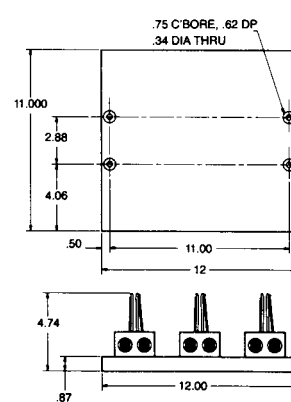

Figure 8



Midget & Class CC

600 Volt Fuse Blocks

FUSE BLOCKS & HOLDERS

600 VOLT MIDGET AND CLASS CC FUSE BLOCKS







Mersen midget fuse blocks accommodate all 30 ampere 1-1/2" x 13/32" midget fuses. Class CC fuse blocks accommodate all 30 ampere Class CC fuses. A choice of box, screw, or pressure-plate connectors fit a wide range of stranded or solid copper wire. Insulators are glass-filled polycarbonate (GFPC) with verified dielectric strength in excess of 2500V. Fuse blocks feature a unique adder block which can be snapped onto 1-, 2- or 3-pole blocks to form multi-pole segmented blocks of as many poles as desired. All fuse clips are made of high conductivity tin-plated copper alloy.

RECOMMENDED FUSE USAGE:

- **Midget Fuse Block** use with ATQ, ATM, A6Y-2B, A25Z-2, TRM, OTM, A15QS-2, GFN, GGU, A60Q-2, DCT
- **Class CC Fuse Block** use with ATDR, ATMR, ATQR

CLIP & CONNECTOR TYPES

30A MIDGET/CC			
COPPER BOX CONNECTOR	SCREW WITH DOUBLE QUICK-CONNECTS	PRESSURE PLATE WITH DOUBLE QUICK-CONNECTS	PRESSURE PLATE WITH DOUBLE QUICK-CONNECTS (CLASS CC REJECTION END)
			

RATINGS:

Midget Block

- **Volts:** 600VAC / DC
- **Amps:** 30A Maximum
- **SCCR:** 100kA (depending on fuse I.R.); 10kA (when using quick connect terminal)

Class CC Block

- **Volts:** 600VAC / DC
- **Amps:** 30A Maximum
- **SCCR:** 200kA, 10kA (when using quick connect terminal)

Temperature/flammability GFPC insulators rated 125°C, 94V-0 flammability.

APPROVALS:

All fuse blocks meet the requirements of UL 4248

Midget Block

- UL recognized component guide IZLT2, File E52283
- CSA certified class 6225, File 32169

Class CC Block

- UL listed, guide IZLT, File E52283
- CSA certified class 6225, File 32169



FB

600 VOLT, 30A MIDGET AND CLASS CC FUSE BLOCKS

Connector		Poles*	Catalog No.				Torque In - lb
Type	Wire Range		Midget	Listing	Class CC	Listing	
Screw w/ double quick connects at both ends	Cu #10-14	ADDER	30310	UL Rec. & CSA	30310R	UL & CSA	20
		1	30311		30311R		
		2	30312		30312R		
		3	30313		30313R		
		4	30314		30314R		
Pressure plate (sems) w/double quick connects at both ends	Cu #10-14	ADDER	30320	UL Rec. & CSA	30320R	UL & CSA	20
		1	30321		30321R		
		2	30322		30322R		
		3	30323		30323R		
		4	30324		30324R		
Copper box	Cu #6-14	ADDER	30350	UL Rec. & CSA	30350R	UL & CSA	35
		1	30351		30351R		
		2	30352		30352R		
		3	30353		30353R		
		4	30354		30354R		

Note: To convert Midget or Class CC adder pole to single pole, use end barrier #U09301.
 * Available in any number of poles. Replace last digit in Catalog Number with number of poles needed.
 Example: 303112 is a 12-pole screw/double QC connector Midget Fuse Block.
 Total width of N poles = (N x .76) + .08 inches. 12 poles = (12 x .76") + .08" = 9.20".

Recommended mounting screws for all Midget and Class CC fuse blocks: #8 (.164" dia.)

DIMENSIONS

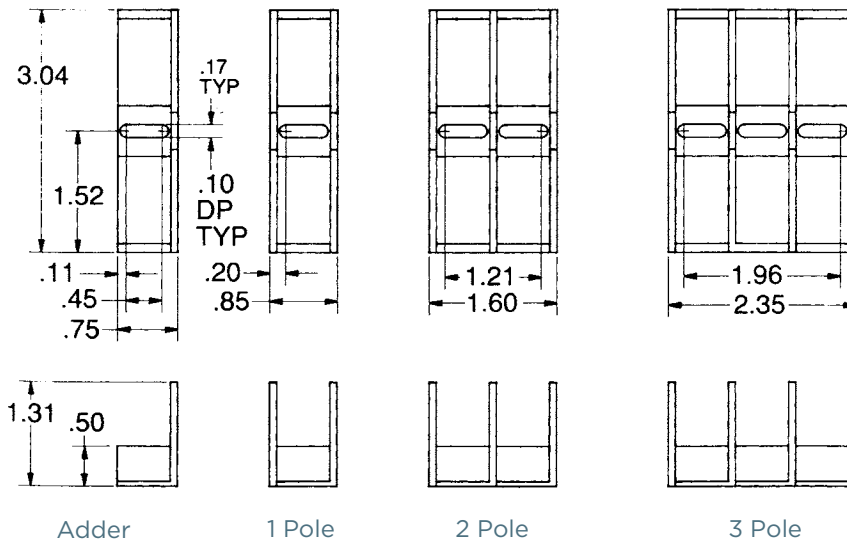

FB

Class H, K & R

250 & 600 Volt Fuse Blocks





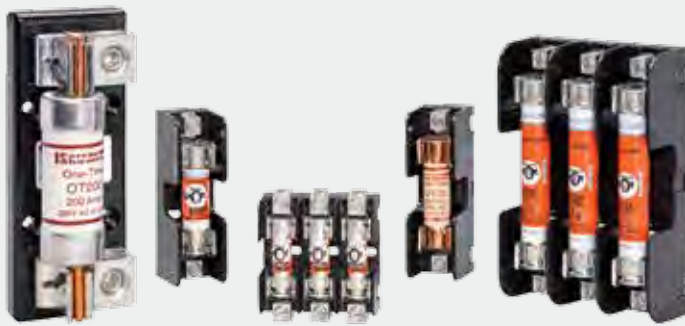









FUSE BLOCKS & HOLDERS

250 & 600V CLASS H, K & R FUSE BLOCKS



FB

Mersen Class H, K and R fuse blocks accommodate all Class H, K and R 250 and 600V power fuses. A choice of screw, pressure plate, box and special order stud connectors fit a wide range of stranded or solid copper or aluminum wire. Insulators are either molded glass-filled polycarbonate (GFPC) or phenolic with verified dielectric strength in excess of 2500V. 30, 60 and 100A fuse blocks feature a unique adder block which can be snapped onto 1-, 2- or 3-pole blocks to form multi-pole segmented blocks of as many poles as desired. All fuse clips are made of high conductivity tin-plated copper, with a choice of spring reinforced or non-spring reinforced clips in 30A and 60A. Clips 100A and above are spring reinforced.

CLIP & CONNECTOR TYPES		
30A & 60A Clips	Connectors	Connectors
Spring Reinforced Class R 	Non-Spring Reinforced 30A & 60A Box 	Spring Reinforced 30A & 60A Box 
Class H & K 	Non-Spring 30A Screw 	Spring 30A Screw (R) 
Non-Spring Reinforced 	Non-Spring 30A Pressure Plate 	Spring 30A Screw 
		Spring Reinforced 30A Pressure Plate 
Connectors		
Spring Reinforced 100A Box 	Spring Reinforced 400A Box In-Line Clip 	
Spring 200A Box Side Clip 	Spring 400A Box Side Clip 	

RATINGS:

- **Volts:** 250VAC/DC, 600VAC/DC
- **Amps:** 30A, 60A, 100A, 200A, 400A, 600A
- **SCCR:** 10kA with class H fuses; 50kA with class K fuses; 200kA with class R fuses

RECOMMENDED FUSE USAGE:

- Class R Blocks (250V) use with A2D-R, A2K-R, TR-R
- Class R Blocks (600V) use with A6D-R, A6K-R, TRS-R
- Class H & K Blocks (250V) use with OT, RF, A2Y types 1 & 3 OTN, CRN, NRN
- Class H & K Blocks (600V) use with OTS, RFS, A6Y types 1 & 3 CRS, NRS

APPROVALS:

- All fuse blocks meet the requirements of UL 4248
- UL listed, guide IZLT, File E52283
- UL recognized component guide IZLT2, file E52283
- CSA certified class 6225, File 32169



250 VOLT, 30 & 60 AMPERE CLASS H, K AND R FUSE BLOCKS

Ampere Rating	Poles	Connector		Catalog No.			Fig.	Connector Torque In - lb
		Type	Wire Range	Class H & K Non-Spring Reinforced	Class H K Spring enforced	Class R Spring Reinforced		
30 GFPC Insulator	ADDER	BOX	Al/Cu #2-14	20300	20305	20305R	1	35
	1			20301*	20306*	20306R*	2	
	2			20302	20307	20307R	3	
	3			20303	20308	20308R	4	
	ADDER	SCREW	Cu #10-14	20310	20315	20315R	1	20
	1			20311*	20316*	20316R*	2	
	2			20312	20317	20317R	3	
	3			20313	20318	20318R	4	
	ADDER	PRESSURE PLATE	Cu #10-14	20320	20325	20325R	1	20
	1			20321*	20326*	20326R*	2	
	2			20322	20327	20327R	3	
	3			20323	20328	20328R	4	
	ADDER	BOX	Cu** #4-14	-	20355	20355R	1	35
	1			-	20356*	20356R*	2	
	2			-	20357	20357R	3	
	3			-	20358	20358R	4	
60 GFPC Insulator	ADDER	BOX	Al/Cu #2-14	20600	20605	20605R	5	45
	1			20601	20606	20606R	6	
	2			20602	20607	20607R	7	
	3			20603	20608	20608R	8	
	ADDER	BOX	Cu** #4-14	-	20655	20655R	5	45
	1			-	20656	20656R	6	
	2			-	20657	20657R	7	
	3			-	20658	20658R	8	

Note: To convert 30A adder pole to single pole, use end barrier #U09322. To convert 60A adder pole to single pole, use end barrier #U09365.

* 1-pole, 30A block does not accept adder pole.

** Fuse blocks have copper box connectors and clips and are for copper wires only. These are specifically designed with the same coefficient of expansion as copper wire for improved heat cycling and meet or exceed OEM "no aluminum" specifications.

Recommended mounting screws for all 30A and 60A fuse blocks: #10 (.190" dia.)

DIMENSIONS

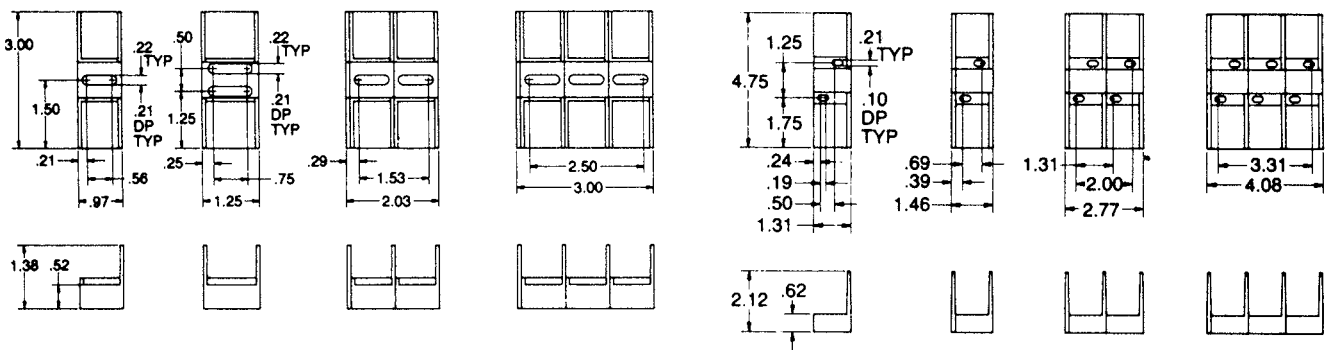

Figure 1

Figure 2

Figure 3

Figure 4

Figure 5

Figure 6

Figure 7

Figure 8

FB

250 VOLT, 100 & 200 AMPERE CLASS H, K AND R FUSE BLOCKS

Ampere Rating	Poles	Connector		Catalog No.		Fig.	Connector Torque In - lb
		Type	Wire Range	Class H & K Spring Reinforced	Class R Spring Reinforced		
100 GFPC Insulator	ADDER	Box	Al/Cu 2/0-#6	21035	21035R	1	120
	1			21036	21036R	2	
	2			21037	21037R	3	
	3			21038	21038R	4	
	ADDER	Box	Cu* 2/0-#12	21005	21005R	1	50
	1			21006	21006R	2	
	2			21007	21007R	3	
	3			21008	21008R	4	
200 Phenolic Insulator	1	Box Side-Clip	Al/Cu 350kcmil-#6	22001	22001R	5	375
	3			22003	22003R	6	
	1	Box Side-Clip	Cu* 350kcmil-#6	22051	22051R	5	275
	3			22053	22053R	6	

Note: To convert 100A adder pole to single pole, use end barrier #U09363.

* Fuse blocks have copper box connectors and clips and are for copper wires only. These are specifically designed with the same coefficient of expansion as copper wire for improved heat cycling and meet or exceed OEM "no aluminum" specifications.

Recommended mounting screws:

All 100A-1/4" (.250" dia.)

200A, 1-pole - #10 (.190" dia.)

200A, 3-pole - 5/16" (.313" dia.)

DIMENSIONS

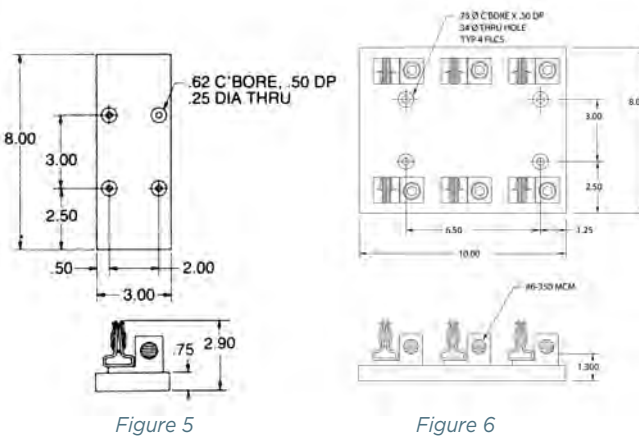
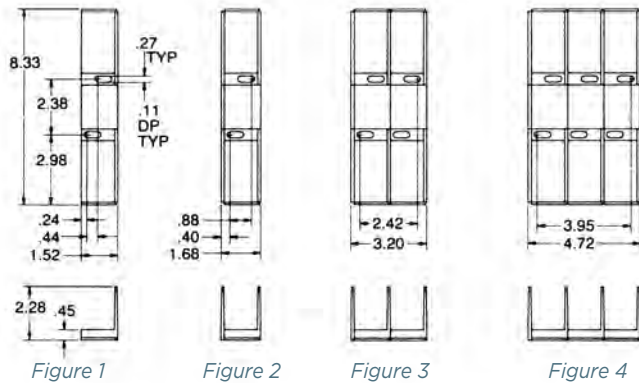

250 VOLT, 400 & 600 AMPERE CLASS H, K AND R FUSE BLOCKS

Ampere Rating	Poles	Connector		Catalog No.		Fig.	Connector Torque In - lb
		Type	Wire Range	Class H & K Spring Reinforced	Class R Spring Reinforced		
400 Phenolic Insulator	1	Box*	Al/Cu	24001	24001R	1	375
	3	Side-Clip	1000-250kcmil	24003	24003R	2	
	1	Box*	Cu**	24051	24051R	1	375
	3	Side-Clip	1000-250kcmil	24053	24053R	2	
	1	Box	Al/Cu	24031	24031R	3	275
	3	In-Line Clip	(2) 350kcmil-#4	24033	24033R	4	
	1	Box	Al/Cu	24061	24061R	3	275
	3	In-Line Clip	(2) 350kcmil-#6	24033	24033R	4	
600 Phenolic Insulator	1	Box	Al/Cu	2631	2631R	5	500
	3	In-Line Clip	(2) 500kcmil-#4	2633	2633R	6	
	1	Box	Cu**	2661	2661R	5	375
	3	In-Line Clip	(2) 500kcmil-#4	2663	2663R	6	

* Not UL Listed or CSA Certified

** Fuse blocks have copper box connectors and clips and are for copper wires only. These are specifically designed with the same coefficient of expansion as copper wire for improved heat cycling and meet or exceed OEM "no aluminum" specifications.

Recommended mounting screws for all 400A and 600A fuse blocks: 5/16 (.313" dia.)

DIMENSIONS

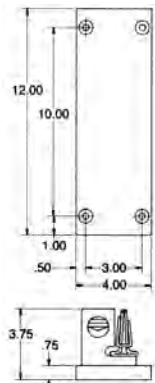

Figure 1

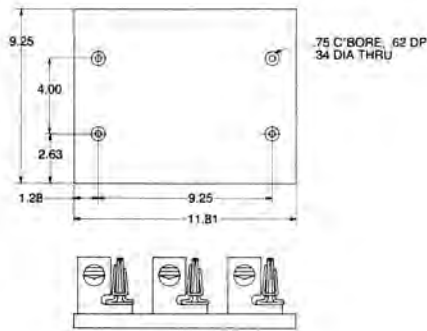

Figure 2

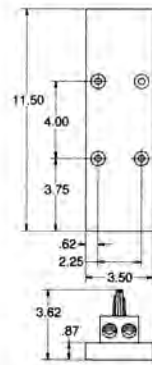

Figure 3

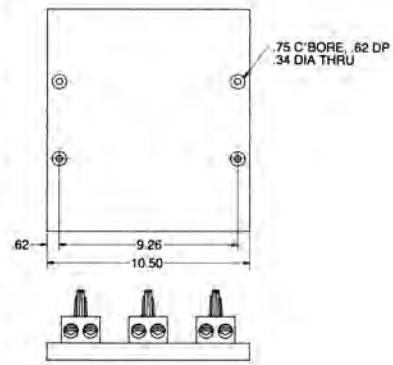

Figure 4

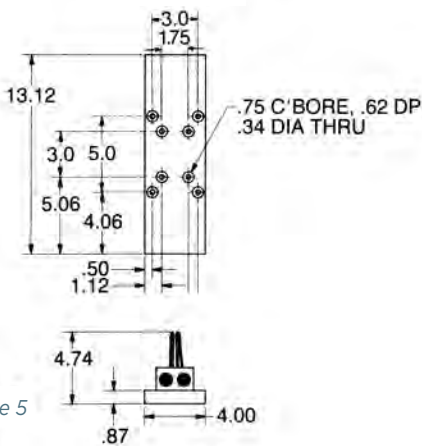

Figure 5

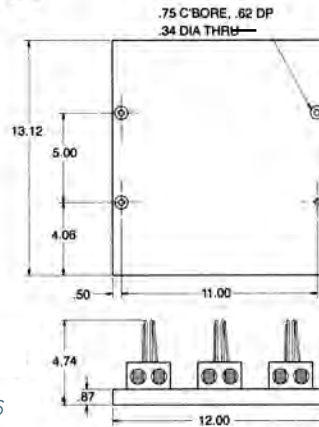

Figure 6

FB

600 VOLT, 30 & 60 AMPERE CLASS H, K AND R FUSE BLOCKS

Ampere Rating	Poles	Connector		Catalog No.			Fig.	Connector Torque In - lb
		Type	Wire Range	Class H & K NonSpring Reinforced	Class H & K Spring Reinforced	Class R Spring Reinforced		
30 GFPC Insulator	ADDER	Box	Al/Cu #2-14	60300	60305	60305R	1	35
	1			60301	60306	60306R	2	
	2			60302	60307	60307R	3	
	3			60303	60308	60308R	4	
	ADDER	Screw	Cu #10-14	60310	60315	60315R	1	20
	1			60311	60316	60316R	2	
	2			60312	60317	60317R	3	
	3			60313	60318	60318R	4	
	ADDER	Pressure Plate	Cu #10-14	60320	60325	60325R	1	20
	1			60321	60326	60326R	2	
	2			60322	60327	60327R	3	
	3			60323	60328	60328R	4	
	ADDER	Box	Cu* #4-14	-	60355	60355R	1	35
	1			-	60356	60356R	2	
	2			-	60357	60357R	3	
	3			-	60358	60358R	4	
60 GFPC Insulator	ADDER	Box	Al/Cu #2-14	60600	60605	60605R	1	45
	1			60601	60606	60606R	2	
	2			60602	60607	60607R	3	
	3			60603	60608	60608R	4	
	ADDER	Box	Cu* #4-14	-	60655	60655R	1	45
	1			-	60656	60656R	2	
	2			-	60657	60657R	3	
	3			-	60658	60658R	4	

Note: To convert 30A or 60A adder pole to single pole, use end barrier #U09361.

* Fuse blocks have copper box connectors and clips and are for copper wires only. These are specifically designed with the same coefficient of expansion as copper wire for improved heat cycling and meet or exceed OEM "no aluminum" specifications.

Recommended mounting screws for all 30A and 60A fuse blocks: 1/4" (.250" dia.)

DIMENSIONS

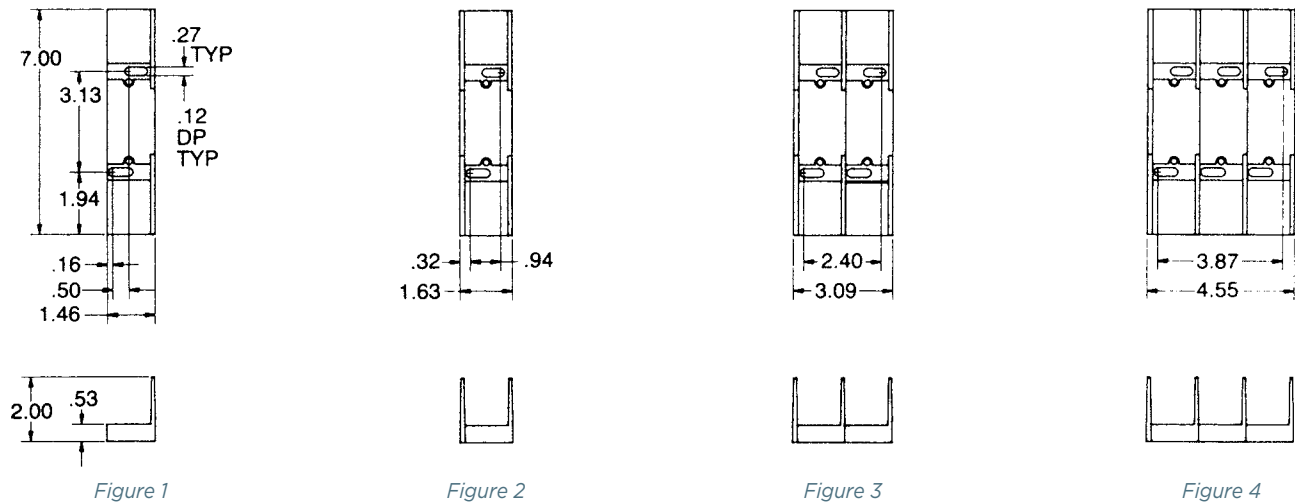

600 VOLT, 100 & 200 AMPERE CLASS H, K AND R FUSE BLOCKS

Ampere Rating	Poles	Connector		Catalog No. Class H & K Spring Reinforced	Class R Spring Reinforced	Fig.	Connector Torque In - lb
		Type	Wire Range				
100 Insulator	ADDER	Box	Al/Cu 2/0-#6	61035	61035R	1	120
	1			61036	61036R	2	
	3			61038	61038R	3	
	ADDER	Box	Cu* 2/0-#12	61005	61005R	1	50
	1			61006	61006R	2	
	3			61008	61008R	3	
200 Insulator	1	Box	Al/Cu	62001	62001R	4	375
	3	Side-Clip	350kcmil-#6	62003	62003R	5	
	1	Box	Cu*	62051	62051R	4	275
	3	Side-Clip	350kcmil-#6	62053	62053R	5	

* Fuse blocks have copper box connectors and clips and are for copper wires only. These are specifically designed with the same coefficient of expansion as copper wire for improved heat cycling and meet or exceed OEM "no aluminum" specifications.

Recommended mounting screws:

All 100A-1/4" (.250" dia.)

200A, 1-pole - #10 (.190" dia.)

200A, 3-pole - 5/16" (.313" dia.)

DIMENSIONS

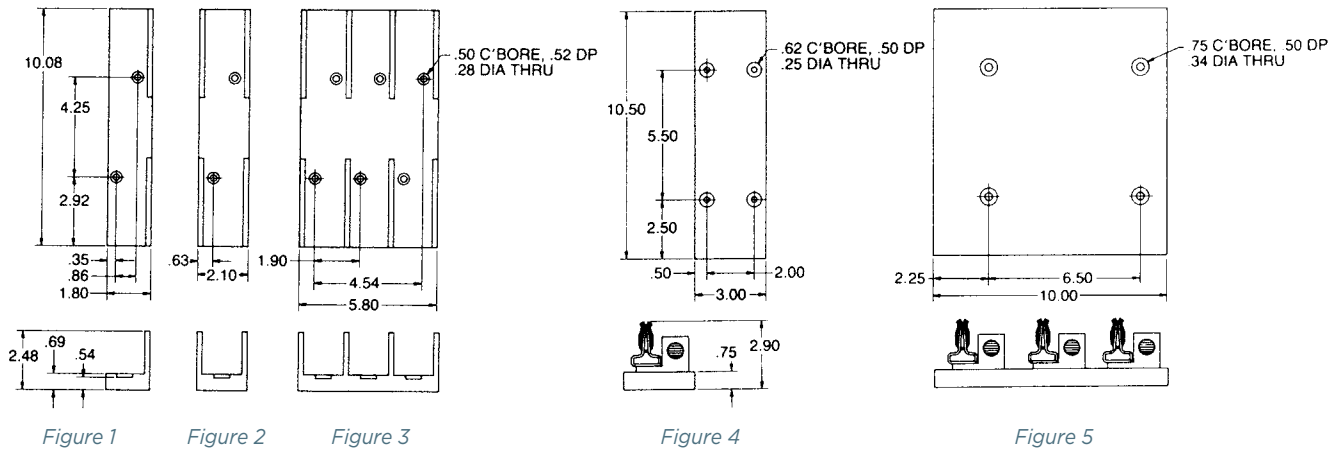

FB

600 VOLT, 400 & 600 AMPERE CLASS H, K AND R FUSE BLOCKS

Ampere Rating	Poles	Connector		Catalog No.		Fig.	Connector Torque In - lb
		Type	Wire Range	Class H & K Spring Reinforced	Class R Spring Reinforced		
400 Phenolic Insulator	1	Box*	Al/Cu	64001	64001R	1	375
	3	Side-Clip	1000-250kcmil	64003	64003R	2	
	1	Box*	Cu**	64051	64051R	1	375
	3	Side-Clip	1000-250kcmil	64053	64053R	2	
	1	Box	Al/Cu	64031	64031R	3	275
	3	In-Line Clip	(2) 350kcmil-#4	64033	64033R	4	
	1	Box	Cu**	64061	64061R	3	275
3	In-Line Clip	(2) 350kcmil-#6	64063	64063R	4		
600 Phenolic Insulator	1	Box	Al/Cu	6631	6631R	5	500
	3	In-Line Clip	(2) 500kcmil-#4	6633	6633R	6	
	1	Box	Cu**	6661	6661R	5	375
	3	In-Line Clip	(2) 500kcmil-#4	6663	6663R	6	

* Not UL Listed or CSA Certified

** Fuse blocks have copper box connectors and clips and are for copper wires only. These are specifically designed with the same coefficient of expansion as copper wire for improved heat cycling and meet or exceed OEM "no aluminum" specifications.

Recommended mounting screws for all 400A and 600A fuse blocks: 5/16 (.313" dia.)

DIMENSIONS

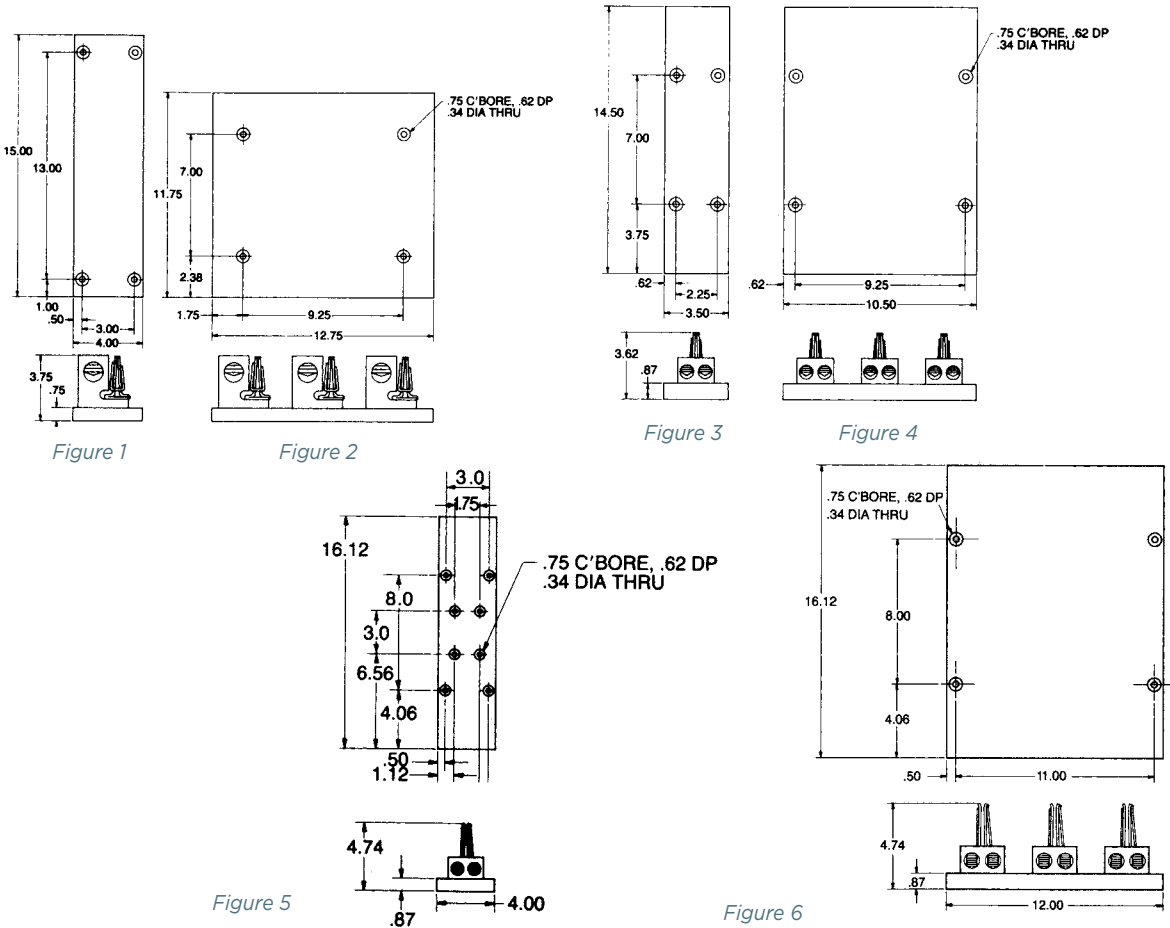

FB

Class T

300 & 600 Volt Fuse Blocks

FUSE BLOCKS & HOLDERS

300 & 600V CLASS T FUSE BLOCKS











Mersen Class T fuse blocks accommodate Class T fuses up to 600A. Insulators are either durable, glass-filled polycarbonate (GFPC) or phenolic with verified dielectric strength in excess of 2500V. Mersen is the only manufacturer to offer Class T blocks with copper connectors.

RECOMMENDED FUSE USAGE:

- Class T Blocks (300V) use with A3T
- Class T Blocks (600V) use with A6T

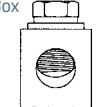
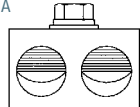
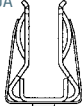
CLIP & CONNECTOR TYPES

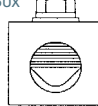
Spring Reinforced 30A & 60A Clips	Connectors for Spring Reinforced 30A & 60A Clips	Connectors	Connectors
300V - 30A 600V - 30A 	30A - 60A Box 	100A Box Side Clip 	400A Box 
300V - 60A 	30A - 60A Screw 	100A Box 	600A Box 
600V - 60A 	30A - 60A Pressure Plate 	200A Box 	

RATINGS:

- **Volts:** 300VAC/DC, 600VAC/DC
- **Amps:** 30A, 60A, 100A, 200A, 400A, 600A
- **SCCR:** 200kA

FEATURES/BENEFITS:

- Unique integral DIN-rail adapters for 600V, 30 & 60A blocks
- Full barrier design (30 & 60A) increases pole to pole safety
- Unique adder-block design (30 & 60A) for design flexibility
- Spring reinforcing standard for all 30 & 60A clips
- Features high conductivity copper alloy fuse clips
- Cool running high amperage (100 - 600A) connectors
- Copper connectors available 30 - 600A

FB

APPROVALS:

- All fuse blocks meet the requirements of UL 4248
- UL listed, guide IZLT, File E52283
- UL recognized component guide IZLT2, file E52283
- CSA certified class 6225, File 32169



300 VOLT, 30 & 60 AMPERE CLASS T FUSE BLOCKS

Ampere Rating	Poles	Connector Type	Wire Range	Catalog No. Spring Reinforced	Fig.	Connector Torque In - lb
30 GFPC Insulator	ADDER			30305T	1	
	1		Al/Cu	30306T	2	
	2	Box	#2-14	30307T	3	35
	3			30308T	4	
	4			30309T	5	
	ADDER			30315T	1	
	1		Cu	30316T	2	
	2	Screw	#10-14	30317T	3	20
	3			30318T	4	
	4			30319T	5	
	ADDER			30325T	1	
	1	Pressure	Cu	30326T	2	
	2	Plate	#10-14	30327T	3	20
	3			30328T	4	
	4			30329T	5	
	ADDER			30355T	1	
	1		Cu*	30356T	2	
	2	Box	#4-14	30357T	3	35
	3			30358T	4	
	4			30359T	5	
ADDER			30615T**	1		
1		Cu	30616T**	2		
2	Screw	#10-14	30617T**	3	20	
3			30618T**	4		
4			30619T**	5		
60 GFPC Insulator	ADDER			30605T	1	
	1		Al/Cu	30606T	2	
	2	Box	#2-14	30607T	3	45
	3			30608T	4	
	4			30609T	5	
	ADDER			30655T	1	
	1		Cu*	30656T	2	
	2	Box	#4-14	30657T	3	45
	3			30658T	4	
	4			30659T	5	

* Fuse blocks have copper box connectors and clips and are for copper wires only. These are specifically designed with the same coefficient of expansion as copper wire for improved heat cycling and meet or exceed OEM "no aluminum" specifications.

** UL Component Recognized

Recommended base mounting screws: #10 (.190" dia.)

DIMENSIONS

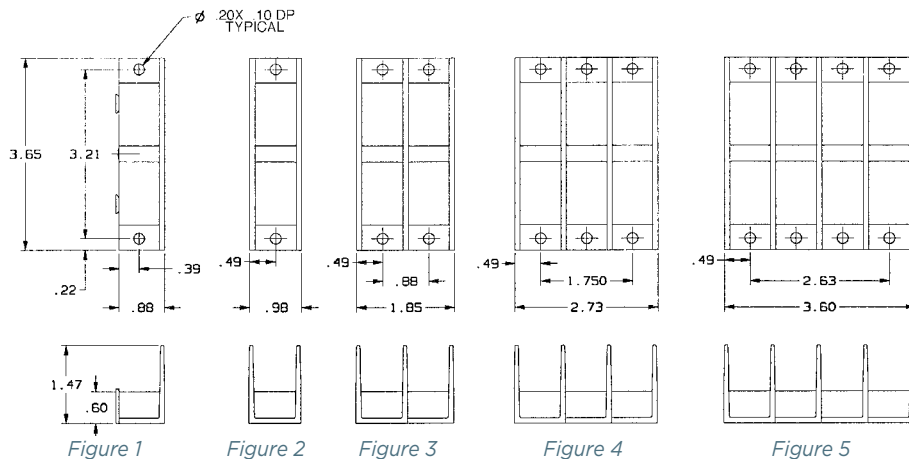

300 VOLT, 100, 200, 400 & 600 AMPERE CLASS T FUSE BLOCKS

Ampere Rating	Poles	Connector		Catalog No.	Fig.	Connector Torque In - lb	
		Type	Wire Range			Connector	Fuse Bolt
100 Phenolic Insulator	1		Cu*	31001T	1		
	2	Box	2/0-#12	31002T	2	50	72
	3			31003T	3		
200 Phenolic Insulator	1	Box	Al/Cu	32031T	4	275	132
	3		350 kcmil-#6	32033T	5		
	1	Box	Cu*	32051T	4	275	132
	3		350 kcmil-#6	32053T	5		
400 Phenolic Insulator	1	Box	Al/Cu	34031T	6	600	228
	3		600 kcmil-#2	34033T	7		
	1	Box	Cu*	34051T	6	375	228
	3		600 kcmil-#2	34053T	7		
600 Phenolic Insulator	1	Box	Al/Cu	36031T	8	600	360
			(2) 600 kcmil-#2				
	1	Box	Cu*	36051T	8	375	360
			(2) 600 kcmil-#2				

† Note: Height includes nominal fuse blade thickness
Recommended base mounting screws:
100A & 200A, #10 (.190" dia.)
400A & 600A, 1/4" (.250" dia.)

Note: * Fuse blocks have copper box connectors and are for copper wires only. These are specifically designed with the same coefficient of expansion as copper wire for improved heat cycling and meet or exceed OEM "no aluminum" specifications.

DIMENSIONS

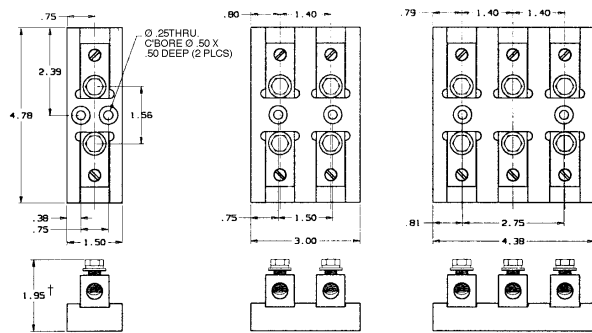

Figure 1

Figure 2

Figure 3

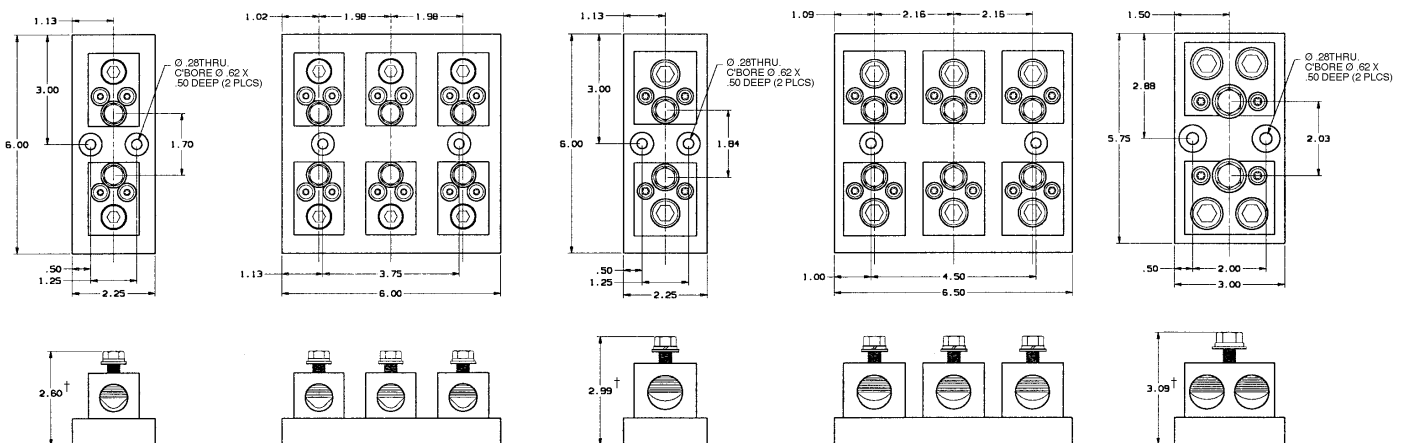

Figure 4

Figure 5

Figure 6

Figure 7

Figure 8

FB

600 VOLT, 30 & 60 AMPERE CLASS T FUSE BLOCKS

Ampere Rating	Poles	Connector		Catalog No. Spring Reinforced	Fig.	Connector Torque In - lb
		Type	Wire Range			
30 GFPC Insulator	ADDER			60305T	1	
	1	Box	Al/Cu	60306T	2	
	2		#2-14	60307T	3	35
	3			60308T	4	
	ADDER			60315T	1	
	1	Screw	Cu	60316T	2	
	2		#10-14	60317T	3	20
	3			60318T	4	
	ADDER			60325T	1	
	1	Pressure	Cu	60326T	2	
	2	Plate	#10-14	60327T	3	20
	3			60328T	4	
	ADDER			60355T	1	
	1	Box	Cu*	60356T	2	
	2		#4-14	60357T	3	35
3			60358T	4		
60 GFPC Insulator	ADDER			60615T**	5	
	1	Screw	Cu	60616T**	6	
	2		#10-14	60617T**	7	20
	3			60618T**	8	
	ADDER			60605T	5	
	1	Box	Al/Cu	60606T	6	
	2		#2-14	60607T	7	45
	3			60608T	8	
	ADDER			60655T	5	
	1	Box	Cu*	60656T	6	
	2		#4-14	60657T	7	45
	3			60658T	8	

* Fuse blocks have copper box connectors and clips and are for copper wires only. These are specifically designed with the same coefficient of expansion as copper wire for improved heat cycling and meet or exceed OEM "no aluminum" specifications.
** UL Component Recognized

Recommended mounting screws:
30A, #10 (.190" dia.)
60A, 1/4" (.250" dia.)

DIMENSIONS

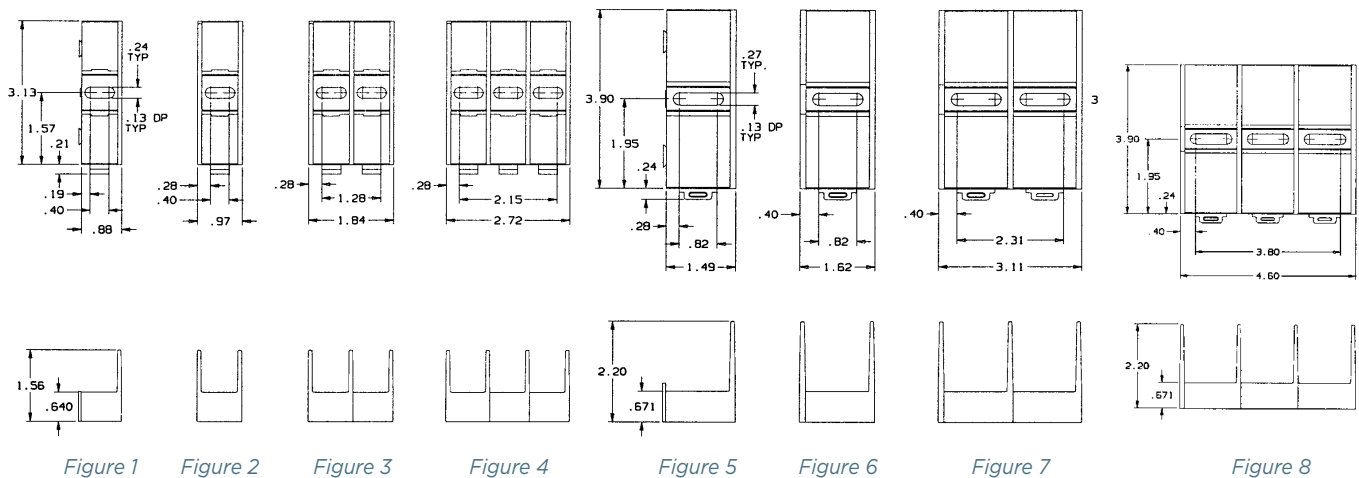

Figure 1

Figure 2

Figure 3

Figure 4

Figure 5

Figure 6

Figure 7

Figure 8

600 VOLT, 100, 200, 400 & 600 AMPERE CLASS T FUSE BLOCKS

Ampere Rating	Poles	Connector		Catalog No. Spring Reinforced	Fig.	Torque (In - Lbs)	
		Type	Wire Range			Connector	Fuse Bolt
100 Phenolic Insulator	1	BOX	Al/Cu 2/0-#6	61031T	1	120	72
	2			61032T	2		
	3			61033T	3		
	1	BOX	Cu* 2/0-#12	61051T	1	50	72
	2			61052T	2		
	3			61053T	3		
200 Phenolic Insulator	1	BOX	Al/Cu 350 kcmil-#6	62031T	4	275	132
	3			62033T	5		
	1			BOX	Cu* 350 kcmil-#6		
	3	62053T	5				
	1	BOX	Al/Cu 600 kcmil-#2			64031T	6
	400 Phenolic Insulator	1	BOX	Cu* 600 kcmil-#2	64051T	6	375
1		BOX	Al/Cu (2) 600 kcmil-#2	66031T	7	600	360
600 Phenolic Insulator	1	BOX	Cu* (2) 600 kcmil-#2	66051T	7	375	360

Note: Fuse blocks have copper box connectors and are for copper wires only. These are specifically designed with the same coefficient of expansion as copper wire for improved heat cycling and meet or exceed OEM "no aluminum" specifications.

Recommended base mounting screws:
100A & 200A, #10 (.190" dia.)
400A & 600A, 1/4" (.250" dia.)

DIMENSIONS

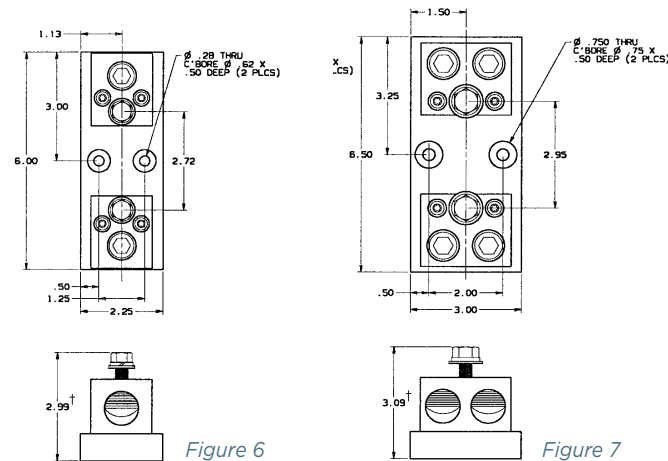
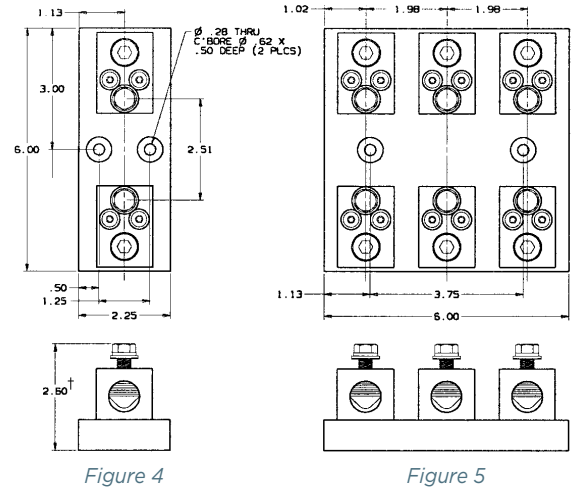
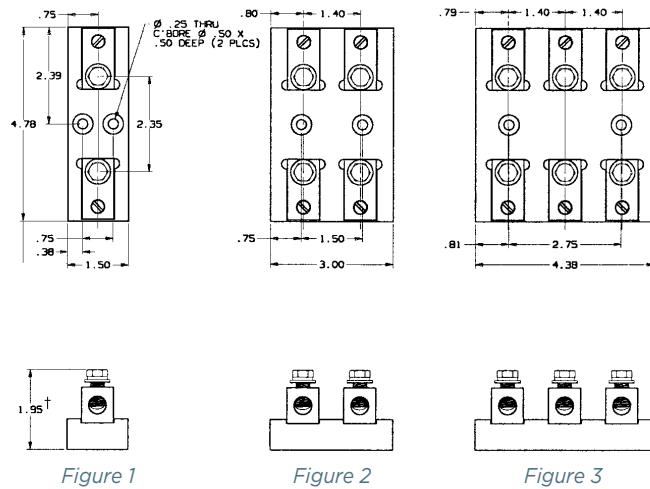

† Note: Height includes nominal fuse blade thickness

FB

Class G

480 & 600 Volt Fuse Blocks

FUSE BLOCKS & HOLDERS

480 & 600V CLASS G FUSE BLOCKS



FB

Mersen Class G fuse blocks accommodate all 15, 20, 30 and 60 ampere Class G fuses. A choice of box, screw or pressure-plate connectors fit a wide range of stranded or solid copper wire. Insulators are glass-filled polycarbonate (GFPC) with verified dielectric strength in excess of 2500V. Fuse blocks feature a unique adder block which can be snapped onto 1-, 2-, or 3-pole blocks to form multi-pole segmented blocks of as many poles as desired. All fuse clips are made of high conductivity tin-plated copper alloy.

RECOMMENDED FUSE USAGE:

Class G Blocks use with AG

CLIP & CONNECTOR TYPES

30, 60A	15, 20, 30A	15, 20, 30A
COPPER BOX CONNECTOR OR ALUMINUM BOX CONNECTOR	SCREW WITH DOUBLE QUICK-CONNECTS	PRESSURE PLATE WITH DOUBLE-QUICK CONNECTS
		

RATINGS:

- **Volts:** 600VAC (15, 20A), 480VAC (30, 60A)
- **Amps:** 15A, 20A, 30A, 60A
- **SCCR:** 100kA, 10kA (when using quick connects)
- **Temperature/Flammability:** GFPC insulators rated 125°C RTI, 94V-0 flammability

FEATURES/BENEFITS:

- Unique integral DIN-rail adapters for 15, 20 & 30A blocks
- Unique adder-block design (all ampere ratings) for design flexibility
- Spring reinforcing standard for 60A clips
- Features high conductivity copper alloy fuse clips

APPROVALS:

All fuse blocks meet the requirements of UL 4248

- UL Listed guide IZLT, File E52283
- CSA Certified class 6225, File 32169



600 VOLT, 15 & 20 AMPERE;
480 VOLT 30 & 60 AMPERE CLASS G FUSE BLOCKS

Ampere Rating	Poles	Connector Type	Wire Range	Catalog No.	Fig.	Torque (In - Lbs)
15 GFPC Insulator	ADDER	Screw w Double Quick Connects at Both Ends	Cu #10-14	40110G	1	20
	1			40111G	2	
	2			40112G	3	
	3			40113G	4	
	ADDER	Pressure Plate (SEMS) w Double Quick Connects at Both Ends	Cu #10-14	40120G	1	20
	1			40121G	2	
	2			40122G	3	
	3			40123G	4	
20 GFPC Insulator	ADDER	Screw w Double Quick Connects at Both Ends	Cu #10-14	40210G	1	20
	1			40211G	2	
	2			40212G	3	
	3			40213G	4	
	ADDER	Pressure Plate (SEMS) w Double Quick Connects at Both Ends	Cu #10-14	40220G	1	20
	1			40221G	2	
	2			40222G	3	
	3			40223G	4	
30 GFPC Insulator	ADDER	Screw w Double Quick Connects at Both Ends	Cu #10-14	40310G	1	20
	1			40311G	2	
	2			40312G	3	
	3			40313G	4	
	ADDER	Pressure Plate (SEMS) w Double Quick Connects at Both Ends	Cu #10-14	40320G	1	20
	1			40321G	2	
	2			40322G	3	
	3			40323G	4	
	ADDER	Copper Box	Cu #6-14	40350G	1	35
	1			40351G	2	
	2			40352G	3	
	3			40353G	4	
60 GFPC Insulator	ADDER	Aluminum Box	Al/Cu #2-14	40605G	5	45
	1			40606G	6	
	2			40607G	7	
	3			40608G	8	
	ADDER	Copper Box	Cu #4-14	40655G	5	45
	1			40656G	6	
	2			40657G	7	
	3			40658G	8	

FB

DIMENSIONS

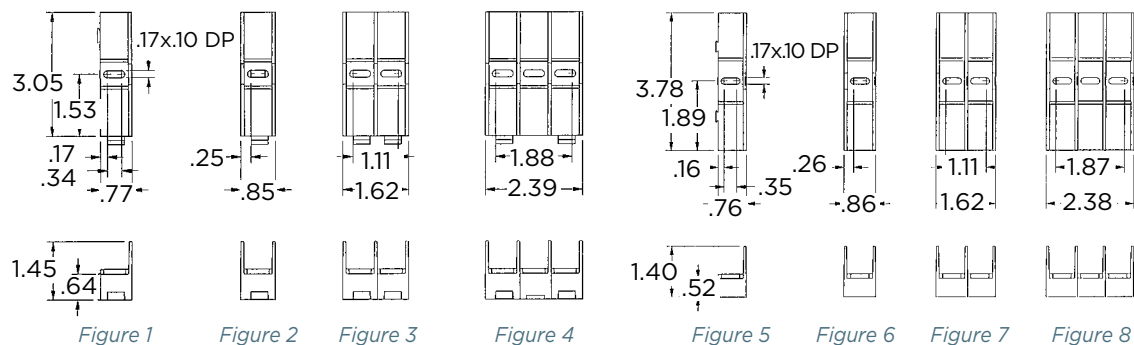

FEB, FEC, FEX, FEY

600 Volt In-Line Fuse Holders

FUSE BLOCKS & HOLDERS



Mersen's complete line of single and dual pole in-line fuse holders accommodate either 1-1/2" x 13/32" (10 x 38 mm) midget or Class CC fuses. The fuse holders are designed for quick installation. Securing nuts or screws are captive thus speeding installation by reducing the need to locate and assemble loose components in the field. Three internal O-rings per pole seal the fuse holder providing a water-resistant compartment for the fuse. The captive O-rings are colored (blue for single pole and red for dual pole) for quick detection. Optional cone shaped insulator boots can be slipped on to provide a watertight seal (breakaway versions come with boots standard). Both single and dual pole versions have an optional breakaway feature which safely disconnects the load in case of a pole knockdown. Fuses remain safely encapsulated within the watertight fuse holder on the load side. Once the pole has been reinstalled the fuse holder can be easily reconnected.

RECOMMENDED FUSE USAGE:

FEB and FEX holders use with:

Midget (1-1/2" x 13/32", 10 x 38 mm): ATQ, ATM, TRM, OTM, GGU, GFN, A13X-2, A25Z-2, A60Q-2, A6Y-2B

FEC and FEY holders use with:

Class CC: ATDR, ATMR, ATQR

RATINGS:

- **Volts:** 600VAC / DC
- **Amps:** 30A Maximum
- **SCCR:** 200kA (Class CC Fuses); 100kA (Midget Fuses)
- **Temperature Rating:** 155°C

APPLICATIONS:

- Street lighting
- Parking lot lighting
- Traffic signaling
- Sports lighting
- Boats and marinas
- Humid/corrosive environments

APPROVALS:

- UL Listed Class CC Guide IZLT, File E52283
- UL Recognized Component Midget Guide IZLT2, File E52283
- CSA Certified Class CC and Midget Class 6225, File 32169



HIGHLIGHTS:

- Breakaway version quickly disconnects line side during pole knockdown in compliance with state and federal highway commission standards
- 3 O-rings per pole for water tight applications
- Colored O-rings for quick detection
- Single and dual poles
- Accepts midget or Class CC fuses
- Wide assortment of terminal variations
- High heat, impact resistant insulator
- Captive nut or screw for quick installations
- Polarized dual pole provides simultaneous disconnection
- Permanently installed neutral versions quickly identified by white nuts
- Tulip fuse clip for improved contact and low losses
- Environmentally friendly-no lead solder used
- Highly visible catalog number even with insulation boots installed
- Wire gauge size identified on insulation boots for quick, accurate trimming
- Time delay for motor starting and transformer inrush

CATALOG NUMBERING SYSTEM

Family	Load Terminal	Line Terminal	Option
FEB-	1	1	-BA

NOMENCLATURE LEGEND

Family	Description
FEB	Single pole midget
FEC	Single pole Class CC
FEX	Dual Pole midget
FEY	Dual pole Class CC
FEBN	Single pole neutral

Notes:

1. Non-breakaway units do not include insulator boots. These optional cone shaped boots are available to provide a watertight installation. The insulator boots are designed to form a watertight seal over conductors, but due to varying wire insulation sizes it is suggested that tape wrap be utilized for best results.
FSB1 = Single conductor boot (used to cover all crimp type & single set screw terminals)
FSB2 = Double conductor boot (used to cover all double set screw (Y-type) terminals)
Insulator boot trimming instructions: Locate wire gage size to be utilized marking on the boot and cut just beneath it.
2. Tightening torque for single and double set screw terminations: 35 lbs.-in.
3. Tightening torque for dual pole fastening screw: 10-15 lbs.-in.
4. FEBN versions have a permanently mounted dummy fuse for neutral applications.

Terminal End View	Terminal	Load or Line Terminal Type					Option Description
		Type	Wire	No. Per	Solid	Stranded	
	11	Cu Crimp	#8-#12 #12-#14	1 2	Yes Yes	Yes Yes	BA (breakaway version equipped with breakaway stud, breakaway boot, and insulating boots for both line and load sides)
	21	Cu Crimp	#10 #6 #4	2 1 1	Yes Yes Yes	Yes Yes No	
	31	Cu Crimp	#10 #4	2 1	Yes No	Yes Yes	
	41	Cu Crimp	#6 #2	2 1	Yes No	Yes Yes	
	81	Cu single Set Screw	#2-#12	1	Yes	Yes	
	91	Cu Double Set Screw	#2-#12	1 each	Yes	Yes	
	82	Al single Set Screw	#2-#12	1	Yes	Yes	
	92	Al double Set Screw	#2-#12	1 each	Yes	Yes	
	S	Cu Stud	N/A	1	N/A	N/A	

FB

MERSEN IN-LINE FUSE HOLDER FAMILY -
TYPICAL COMBINATION CHART

Midget 10x38mm	Midget 10x38mm Breakaway	Class CC	Class CC Breakaway	Midget 10x38mm Dual Pole	Midget 10x38mm Dual Pole Breakaway	Class CC Dual Pole	Class CC Dual Pole Breakaway
FEB-11-11	FEB-11-11-BA	FEC-11-11	FEC-11-11-BA	FEX-11-11	FEX-11-11-BA	FEY-11-11	FEY-11-11-BA
FEB-11-21	FEB-11-21-BA	FEC-11-21	FEC-11-21-BA	FEX-11-21	FEX-11-21-BA	FEY-11-21	FEY-11-21-BA
FEB-11-31				FEX-11-31		FEY-11-31	
FEB-11-41	FEB-11-41-BA			FEX-11-41	FEX-11-41-BA	FEY-11-41	
	FEB-11-81-BA						
FEB-11-82	FEB-11-82-BA						
FEB-11-91	FEB-11-91-BA	FEC-11-91	FEC-11-91-BA				FEY-11-91-BA
FEB-11-92	FEB-11-92-BA						
FEB-11-S							
FEB-21-11							
FEB-21-21	FEB-21-21-BA	FEC-21-21	FEC-21-21-BA	FEX-21-21	FEX-21-21-BA	FEY-21-21	FEY-21-21-BA
FEB-21-91	FEB-21-91-BA						
FEB-31-31	FEB-31-31-BA						
FEB-41-41	FEB-41-41-BA						
FEB-81-81	FEB-81-81-BA	FEC-81-81	FEC-81-81-BA	FEX-81-81			FEY-81-81-BA
FEB-81-91	FEB-81-91-BA			FEX-81-91	FEX-81-91-BA	FEY-81-91	
FEB-81-S							
FEB-82-82	FEB-82-82-BA						
FEB-82-92	FEB-82-92-BA						
	FEB-91-91-BA				FEX-81-91-BA		
FEBN-11-11	FEBN-11-11-BA						
FEBN-11-91	FEBN-11-91-BA						
FEBN-81-81	FEBN-81-81-BA						
FEB-SS							
					FEX-81-91-BA		

Note: Consult factory for other configurations.

CRIMPING TOOLS REFERENCE CHART, THE FOLLOWING
CRIMPING TOOLS (OR EQUIVALENT) ARE RECOMMENDED:

Terminal Type	FCI-Burndy	T&B
1	Y8MRB-1	WT-111M
2	Y2MR	TBM2/TBM5 BLUE DIE, WT-115-A DIE O
3	Y2MR	TBM2/TBM5 GREY DIE, WT-115-A DIE E
4	Y2MR	TBM2/TBM5 BROWN DIE, WT-115-A DIE F

FEB AND FEC, NON-BREAKAWAY AND BREAKAWAY
ASSEMBLY DRAWINGS

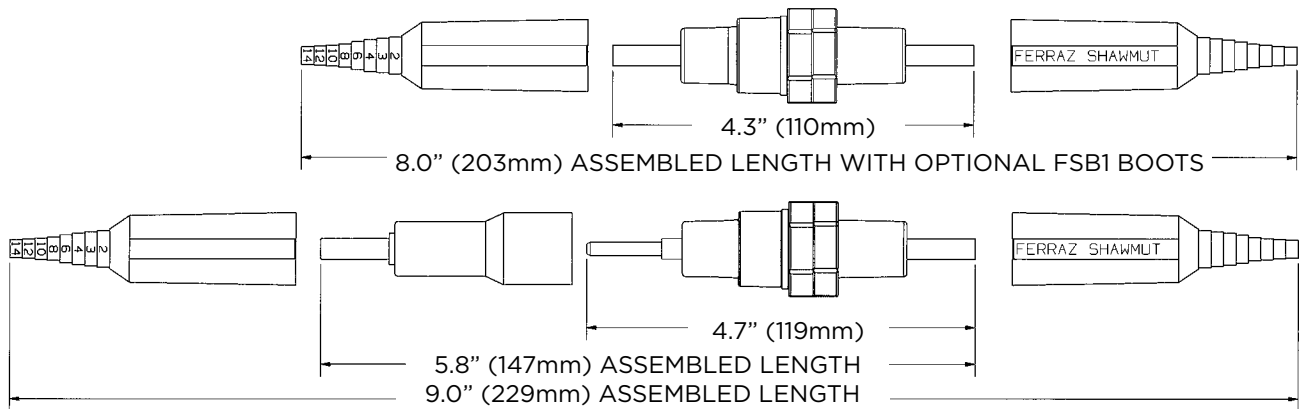

FEX AND FEY, NON-BREAKAWAY AND BREAKAWAY
ASSEMBLY DRAWINGS

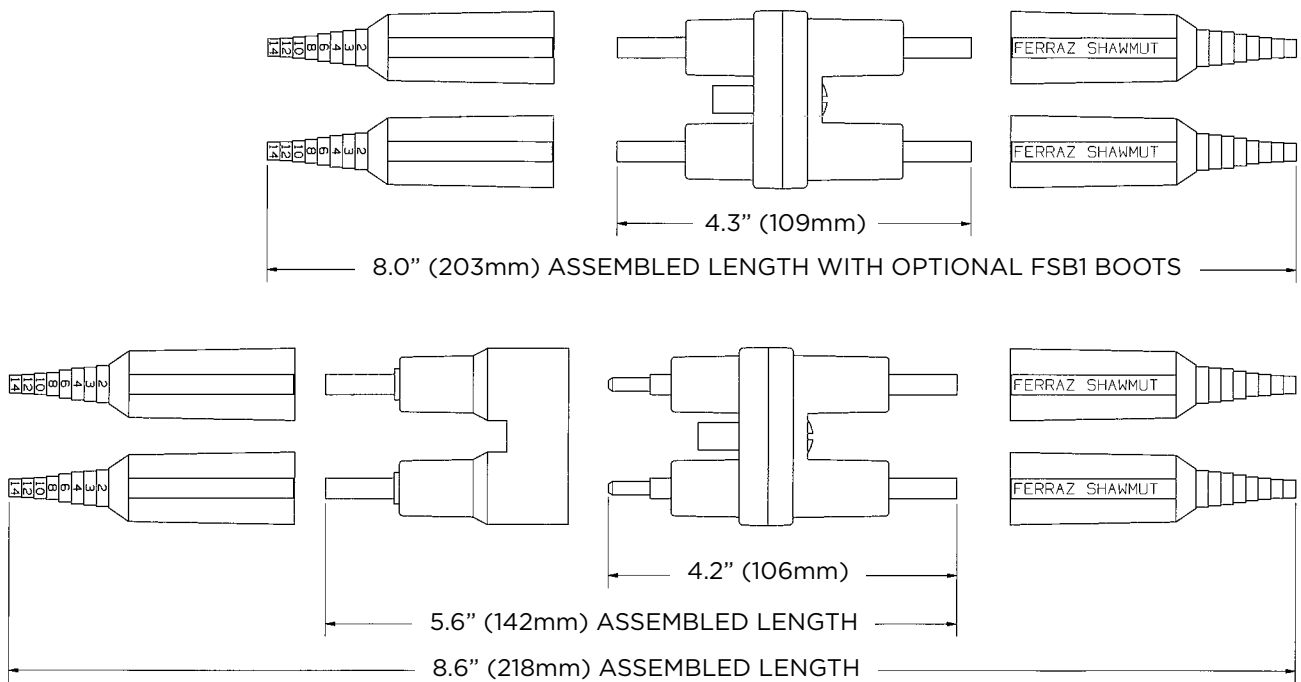

FB

HPJ

1000VDC Class J Open Style Fuse Holders

FUSE BLOCKS & HOLDERS

MERSEN PV APPROVED CLASS J FUSE HOLDERS FOR USE WITH CLASS J PHOTOVOLTAIC FUSES



FB

Designed specifically for Mersen's HP6J series of photovoltaic fuses, these fuse holders are certified for use with 90°C temperature rated conductors, an industry first. Fuse holders are available with box connectors, stud connectors or a combination of the two in order to meet various customer requirements. Insulators are either molded glass-filled polycarbonate or phenolic with verified dielectric strength in excess of 2500V. All fuse clips are made of high conductivity tin-plated copper.

CATALOG NUMBERS

Ampere Rating	Clip Configuration	Wire Range	Wire Type	Stud Type	Catalog Number	Temperature Rating of Wire Terminal
BOX TO BOX TERMINAL CONFIGURATION, 1-POLE						
100	In-line	2/0 - #6	Cu	—	61006HPJ	90°C
200	Side	350kcmil - #6	Al/Cu	—	62001HPJ	
400	In-line	{2} 350kcmil - #6		—	64031HPJ	
600	In-line	{2} 500kcmil - #4	—	—	6631HPJ	75°C
BOX TO STUD TERMINAL CONFIGURATION, 1-POLE						
100	In-line	2/0 - #6	Cu	1/4-20	61041HPJ	90°C
200	Side	350kcmil - #6	Al/Cu	5/16-18	62041HPJ	
400	In-line	{2} 350kcmil - #6		3/8-16	64041HPJ	
600	In-line	{2} 500kcmil - #4	—	1/2-13	6641HPJ	75°C
STUD TO STUD TERMINAL CONFIGURATION, 1-POLE						
100	In-line	—	Al/Cu	1/4-20	61016HPJ	N/A
200	Side	—		5/16-18	62011HPJ	
400	In-line	—		3/8-16	64011HPJ	
600	In-line	—		1/2-13	6611HPJ	

RATINGS:

- **Volts:** 1000VDC
- **Amps:** 100A, 200A, 400A, 600A
- **SCCR:** 100kA

FEATURES/BENEFITS:

- UL approved for use with 90°C temperature rated conductors
Box and/or stud wire terminals available
- UL Listed to UL's standard for photovoltaic fuse holders

APPLICATIONS:

- Re-combiner box (sub-combiner, array combiner, master combiner) applications
- Inverter DC input
- Battery charge controllers

RECOMMENDED FUSE USAGE:

- Mersen HP6J series HeliProtection photovoltaic fuses

APPROVALS:

- UL Listed to Standard 4248-18
- CSA Component Certified C22.2

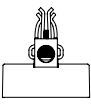
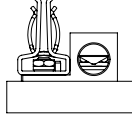
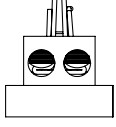
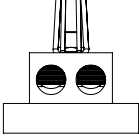
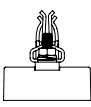
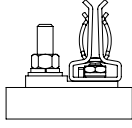
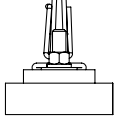
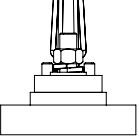

CLIP & CONNECTOR TYPES

100A	200A	400A	600A
<p>Box Connector</p> 	<p>Box Connector</p> 	<p>Box Connector</p> 	<p>Box Connector</p> 
<p>Stud Connector</p> 	<p>Stud Connector</p> 	<p>Stud Connector</p> 	<p>Stud Connector</p> 

DIMENSIONS*

100A

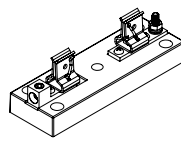
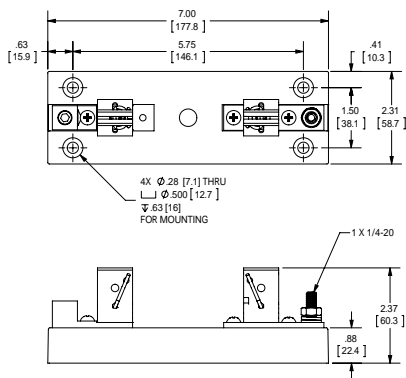

200A

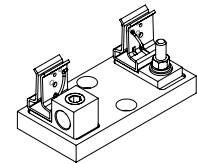
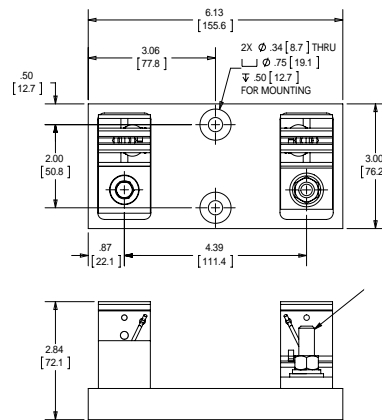

400A

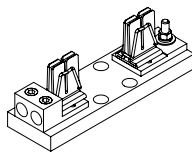
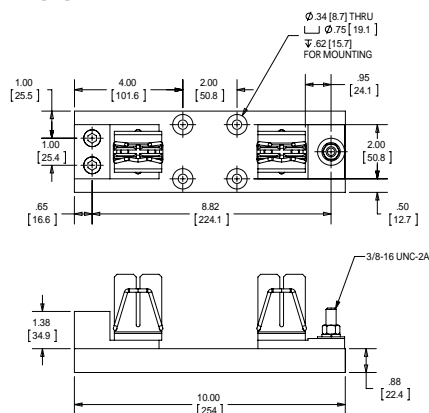

600A

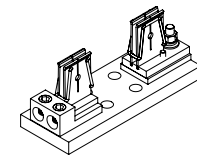
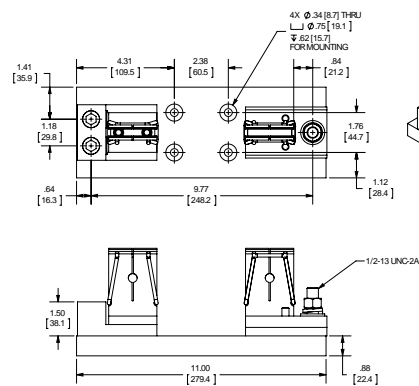

*Box to Stud Terminal configuration shown for reference only. Also available in box-box and stud-stud terminal configurations.

FB

US15M1HEL

UltraSafe™ Fuse Holders for PV

FUSE BLOCKS & HOLDERS

TOUCH-SAFE DESIGN INCREASES USER SAFETY



FB

Mersen UltraSafe modular fuse holders introduce the next level of safety for Photovoltaic applications for 10x85mm fuses. UltraSafe fuse holders are finger safe up to an IP20 grade of protection, and the 10x85mm features a pull out, pivoting fuse carrier.

The US15M1HEL is designed with terminals to accept standard stock bus bar eliminating the need for custom combed bus bar, saving cost, time and simplifying installation. The body features industry leading UL94V0 material, providing superior flammability rating with exceptional durability.

DIMENSIONS:

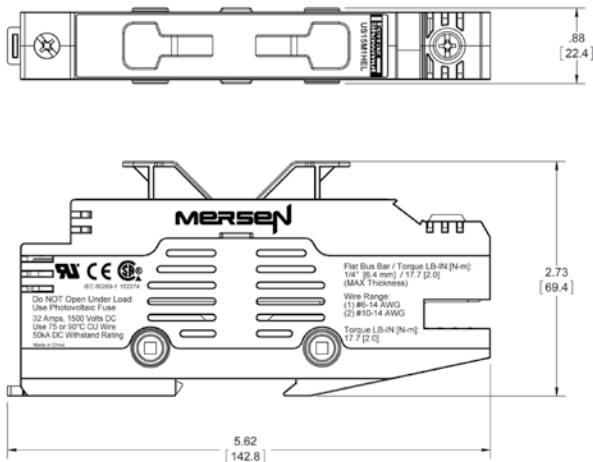

RATINGS:

Volts: 1500VDC Maximum

Amps: 32A Maximum

SCCR: 50kA

FEATURES/BENEFITS:

- Bus bar termination clamp
- UL94V0 Material Flammability Rating
- Wire terminal for use with 90°C wire
- Wire range: 6-14 stranded, 10-14 solid. Copper wire only.
- IP20 Finger Safe
- DIN-Rail Mounting
- Recommended fuse usage: HP15M

APPLICATIONS:

- All photovoltaic applications
- Combiner box applications

APPROVALS:

- UL Recognized Component, evaluated to UL 4248-18



HP15FHM32

HelioProtection® Fuse Holders for PV Applications

FUSE BLOCKS & HOLDERS

TOUCH-SAFE DESIGN INCREASES USER SAFETY



Mersen's 1500 VDC HelioProtection fuse holders for 10/14x85mm gPV fuses introduce the next level of safety for Utility scale photovoltaic applications. The HP15FHM32 fuse holders are finger safe (IP20 ingress protection rated), featuring a rotating fuse carrier, similar to the Mersen UltraSafe® fuse holders.

The HP15FHM32 series input and output terminals accept standard PV rated wiring and comb bus bars, providing added versatility for end-use installations. The body features high performance UL 94 V-0 rated polymer material, providing superior flammability rating, with exceptional durability and dielectric withstand properties.

RATINGS:

- **Volts:** 1500VDC Maximum
- **Amps:** 32ADC Maximum
- **Power Dissipation:** 6.0 W Maximum
- **SCCR:** 50kA DC

APPLICATIONS:

- All Utility scale photovoltaic applications
- 1500VDC Combiner Boxes

APPROVALS:

- UL 4248-19
- CSA 22.2 No. 4248.19
- IEC 60269-2

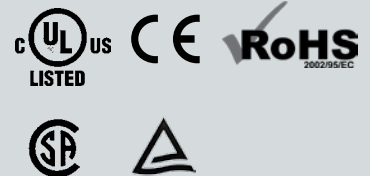

FB

FEATURES/BENEFITS:

- Wire in/out terminals
- Clamping: Screw clamp, #2 combo head (Tool-less spring clamp version available soon)
- UL 94 V-0 rated
- Use with PV-rated copper wire
- Wire range: 1X #4 - #14 AWG (25 - 2.5 mm²); 2X #8 - 18 AWG (10 - 0.75 mm²)
- Required terminal torque: 22 in-lb/2.5N-m
- IP20 rated (finger safe)
- 35 mm DIN Rail Mounting
- Lock Out/Tag Out feature
- Area for customer-applied labeling
- Digital Multimeter (DMM) probe access
- Accepts 10/14 x 85mm gPV fuses
- Recommended gPV fuses: HP15M
- Operating Temperature: -40 to +125°C
- Front loading of the fuse - allows for ease of installation and removal of fuse

DIMENSIONS (MM):

HP15FHM32A

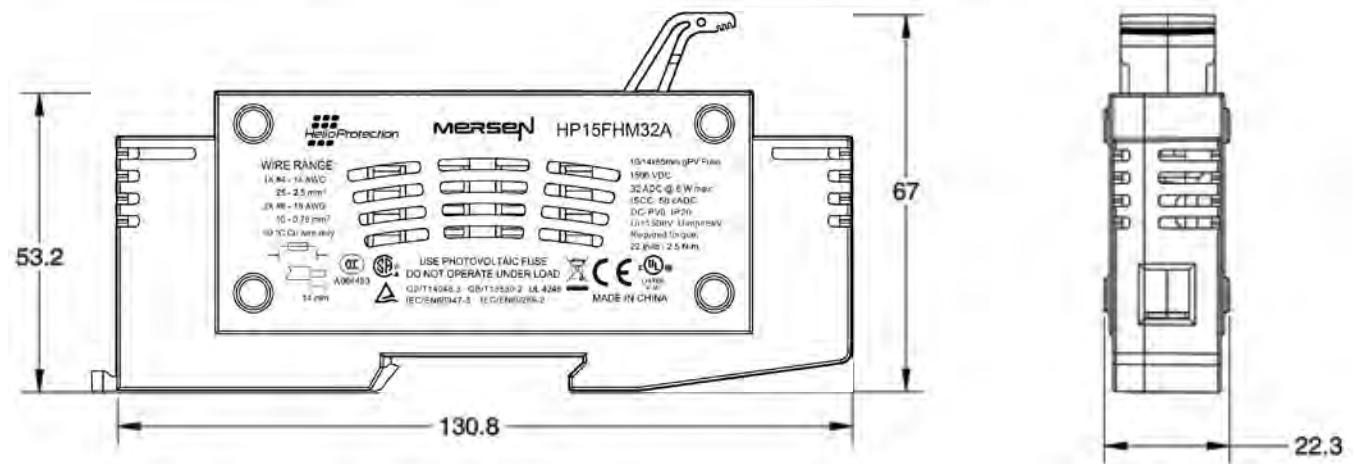

FB

HPBB

1000V DC Size NH Open Style Fuse Blocks

FUSE BLOCKS & HOLDERS

MERSEN SIZE NH FUSE BLOCKS FOR USE WITH HP10NH HELIOPROTECTION® PHOTOVOLTAIC SERIES FUSES



1000VDC rated and designed specifically for Mersen's HP10NH series of photovoltaic fuses. These polyester fuse blocks are available in single pole configurations with or without finger-safe covers. Fuse blocks come standard with M10 stud connectors for ease of wire termination. All fuse clips are silver-plated copper and fuse clips are spring re-enforced for superior conductivity. Select Mersen's brand of innovative HeliProtection® products to meet your stringent photovoltaic application requirements.

CATALOG NUMBERS - FUSE BLOCK

Catalog Number	Reference Number	No. of Poles	For use with	Description
HPBB11PPR	A1030607	1	NH1	Open Style
HPBB11PPRFS	K1032916			Open Style with Protective Cover
HPBB21PPR	C1037509	1	NH2	Open Style
HPBB21PPRFS	D1037510			Open Style with Protective Cover

DIMENSIONS (MM)

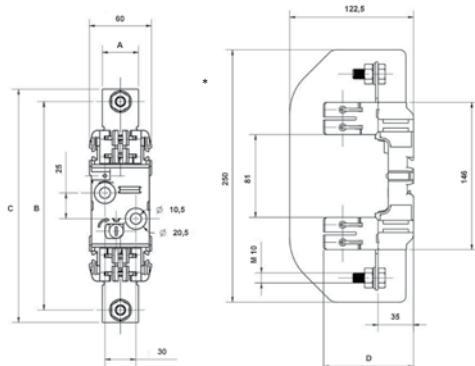

*87mm for base with protective cover

M10 torque recommendation:
230 in-lbs (26 Nm)

Size	NH1	NH2
A	32	35
B	176	201
C	209	225
D	80	89

RATINGS:

- **Volts:** 1000VDC
- **Amps:** 315A max
- **SCCR:** 50kA

FEATURES:

- 1000VDC rated
- Polyester insulating base
- Silver plated contacts
- M10 stud wire terminals
- Optional finger-safe covers
- DIN-rail or screw mounting

APPLICATIONS:

- Re-combiner box (sub-combiner, array combiner, master combiner) applications
- Inverter DC input
- Battery charge controllers

RECOMMENDED FUSE USAGE:

Mersen HP10NH series HeliProtection Photovoltaic Fuses

APPROVALS:

- IEC 60269-2-1 Certification
- Pending: UL Listed to Standard 4248-18, File E347822



Type EK 9F61 Series

Medium Voltage Fuse Holders & Clips

FUSE BLOCKS & HOLDERS

FUSE SUPPORTS, FUSE DISCONNECT SWITCHES, AND ACCESSORIES FROM 2.4KV TO 38KV

Fuse supports, non-disconnecting, are used primarily in potential transformer circuits, or where there is some other disconnecting or isolating device in series with the fuse in the circuit. Disconnecting switch devices have the additional feature of serving to isolate the equipment they protect. It should be noted that disconnecting switches are not load-breaking devices, therefore, the circuit must be open prior to the fuse disconnection. Select either a fuse support or a disconnecting switch for each fuse. Fuse supports and disconnecting switches include live parts for both ends. Both fuse supports and fuse disconnect switches can be mounted vertically or horizontally. The type EK are used for indoor installations while the type EKO are used outdoors.

Indoor:

Fuse supports:EK-1

Fuse disconnect switches: EK-3

Outdoor:

Fuse supports: EKO-1

Fuse disconnect switches: EKO-3

The letter suffix following the (-1) or the (-3) shows the fuse size.

When selecting a mounting for a current-limiting fuse, it is necessary that the clip centers and size agree with the fuse selected.

For detailed information regarding these fuse supports and disconnecting switches such as storage, mounting and maintenance, please refer to INST-EK39196 available on our website at ep.mersen.com or ask your sales representative for a hard copy.

Fuse Size	Ferrule Diameter
B	1.9/16 inches
C	2 inches
D	3 inches
DD	two-3 inch in parrallel
DDDD	four-3 inch in parrallel
EE	two-4 inch in parrallel

FUSE SUPPORT - EK-1 INDOOR



EK-1B



EK-1C



EK-1D



EK-1DD



EK-1EE



EK-1DDDD

Refer to drawings for specific dimensions.

FUSE SUPPORT - EK-1 INDOOR

Catalog No.	Max. kV	Ferrule Size/ Diam.	Clip Centers	Spare Parts (Live Parts)	Spare Parts (Clips)	Insulator Rating - Class/NEMA Nominal Sys. (kV)	Insulator Rating - BIL (kV)	Insulator Rating - Class/NEMA Tech Ref.
9F61ABB101	2.75/5.5	B/1.56"	8.12"	9F61BNW450	9F61BWW460	4.8	60	A-20
9F61ABG101	8.25	B/1.56"	8.12"	9F61BNW450	9F61BWW460	13.8	95	A-20
9F61ADG101	15.5	B/1.56"	11.5"	9F61BNW450	9F61BWW460	13.8	95	A-20
9F61ADJ101	15.5	B/1.56"	11.5"	9F61BNW450	9F61BWW460	14.4	110	A-20
9F61AAB201	2.75	C/2.00"	7"	9F61BNW451	9F61BWW457	4.8	60	A-20
9F61ACB201	5.5	C/2.00"	9"	9F61BNW451	9F61BWW457	4.8	60	A-20
9F61AEG201	15.5	C/2.00"	12"	9F61BNW451	9F61BWW457	13.8	95	A-20
9F61AGG201	15.5	C/2.00"	15"	9F61BNW451	9F61BWW457	13.8	95	A-20
9F61AGJ201	15.5	C/2.00"	15"	9F61BNW451	9F61BWW457	14.4	110	A-20
9F61AHM201	25.8	C/2.00"	21"	9F61BNW743	9F61BWW457	23	150	A-20
9F61AAB301	2.75	D/3.00"	7"	9F61BNW750	9F61BWW459	4.8	60	A-20
9F61AEB301	2.75/5.5	D/3.00"	12"	9F61BNW750	9F61BWW459	4.8	60	A-20
9F61AEG301	8.25	D/3.00"	12"	9F61BNW750	9F61BWW459	13.8	95	A-20
9F61AGG301	15.5	D/3.00"	15"	9F61BNW750	9F61BWW459	13.8	95	A-20
9F61AGJ301	15.5	D/3.00"	15"	9F61BNW750	9F61BWW459	14.4	110	A-20
9F61AHM301	25.8	D/3.00"	21"	9F61BNW744	9F61BWW459	23	150	A-20
9F61AAB401	2.75	DD/3.00"	7"	9F61BNW751	-	4.8	60	A-20
9F61AEB401	2.75/5.5	DD/3.00"	12"	9F61BNW751	-	4.8	60	A-20
9F61AEG401	8.25	DD/3.00"	12"	9F61BNW751	-	13.8	95	A-20
9F61AGG401	15.5	DD/3.00"	15"	9F61BNW751	-	13.8	95	A-20
9F61AGJ401	15.5	DD/3.00"	15"	9F61BNW751	-	14.4	110	A-20
9F61AHM401	25.8	DD/3.00"	21"	9F61AWW738	-	23	150	A-20
9F61AFB501	5.08	EE/4.00"	14.12"	9F61BNW452	-	4.8	60	A-20
9F61AFG501	15	EE/4.00"	14.12"	9F61BNW452	-	13.8	95	A-20
9F61AFJ501	15	EE/4.00"	14.12"	9F61BNW452	-	14.4	110	A-20
9F61AHG001	15	DDDD		For Bolted-end Fuses refer to drawings.			96	
9F61AKB001	5.5	DDDD		For Bolted-end Fuses refer to drawings.			60	

DISCONNECT SWITCH - EK-3 INDOOR



EK-3C



EK-3D



EK-3DD

Catalog No.	Max. kV	Ferrule Size/ Diam.	Clip Centers	Spare Parts [Live Parts]	Spare Parts [Clips]	Insulator Rating - Nominal Sys. (kV)	Insulator Rating - BIL (kV)	Insulator Rating - Class/NEMA Tech Ref.
9F61AAB205	2.75	C/2.00"	7"	9F61BNW731	9F61BWW457	4.8	60	A-20
9F61ACB205	5.5	C/2.00"	9"	9F61BNW731	9F61BWW457	4.8	60	A-20
9F61AEG205	15.5	C/2.00"	12"	9F61BNW731	9F61BWW457	13.8	95	A-20
9F61AGG205	15.5	C/2.00"	15"	9F61BNW731	9F61BWW457	13.8	95	A-20
9F61AGJ205	15.5	C/2.00"	15"	9F61BNW731	9F61BWW457	14.4	110	A-20
9F61AHM205	25.8	C/2.00"	21"	9F61BNW746	9F61BWW457	23	150	A-20
9F61AAB305	2.75	D/3.00"	7"	9F61BNW732	9F61BWW459	4.8	60	A-20
9F61AEB305	2.75/5.5	D/3.00"	12"	9F61BNW732	9F61BWW459	4.8	60	A-20
9F61AEG305	8.25	D/3.00"	12"	9F61BNW732	9F61BWW459	13.8	95	A-20
9F61AGG305	15.5	D/3.00"	15"	9F61BNW732	9F61BWW459	13.8	95	A-20
9F61AGJ305	15.5	D/3.00"	15"	9F61BNW732	9F61BWW459	14.4	110	A-20
9F61AHM305	25.8	D/3.00"	21"	9F61BNW747	9F61BWW459	23	150	A-20
9F61AAB405	2.75	DD/3.00"	7"	9F61BNW461	-	4.8	60	A-20
9F61AEB405	2.75/5.5	DD/3.00"	12"	9F61BNW461	-	4.8	60	A-20
9F61AEG405	8.25	DD/3.00"	12"	9F61BNW461	-	13.8	95	A-20
9F61AGG405	15.5	DD/3.00"	15"	9F61BNW461	-	13.8	95	A-20
9F61AGJ405	15.5	DD/3.00"	15"	9F61BNW461	-	14.4	110	A-20
9F61AHM405	25.8	DD/3.00"	21"	9F61BNW748	-	23	150	A-20

Refer to drawings for specific dimensions.

FUSE SUPPORT - EKO-1 OUTDOOR



EKO-1C



EKO-1D



EKO-1DD



EKO-1DDDD

Catalog No.	Max. kV	Ferrule Size/Diam.	Clip Centers	Spare Parts (Live Parts)	Spare Parts (Clips)	Insulator Rating - Nominal Sys. (kV)	Insulator Rating - BIL (kV)	Insulator Rating - Class/NEMA Tech Ref.
9F61CEF209	2.75/5.5/8.25	C/2.00"	12"	9F61BNW743	9F61BWW457	7.5	95	202
9F61CGL209	15.5	C/2.00"	15"	9F61BNW743	9F61BWW457	15	110	205
9F61CHM209	25.8	C/2.00"	21"	9F61BNW743	9F61BWW457	23	150	208
9F61CEF309	2.75/5.5/8.25	D/3.00"	12"	9F61BNW744	9F61BWW459	7.5	95	202
9F61CGL309	15.5	D/3.00"	15"	9F61BNW744	9F61BWW459	15	110	205
9F61CHM309	25.8	D/3.00"	21"	9F61BNW744	9F61BWW459	23	150	208
9F61CJN309	38	D/3.00"	27"	9F61BNW744	9F61BWW459	34.5	200	210
9F61CEF409	2.75/5.5/8.25	DD/3.00"	12"	9F61AWW738	-	7.5	95	202
9F61CGL409	15.5	DD/3.00"	15"	9F61AWW738	-	15	110	205
9F61CHM409	25.8	DD/3.00"	21"	9F61AWW738	-	23	150	208
9F61CJN409	38	DD/3.00"	27"	9F61AWW738	-	34.5	200	210
9F61CKF009	5.5	DDDD	For Bolted-end Fuses refer to drawings.					

Refer to drawings for specific dimensions.

DISCONNECT SWITCH - EKO-3 OUTDOOR



EKO-3C



EKO-3D Open Position



EKO-3DD

Catalog No.	Max. kV	Ferrule Size/Diam.	Clip Centers	Spare Parts (Live Parts)	Spare Parts (Clips)	Insulator Rating - Nominal Sys. (kV)	Insulator Rating - BIL (kV)	Insulator Rating - Class/ NEMA Tech Ref.
9F61CEF210	2.75/5.5/8.25	C/2.00"	12"	9F61BNW746	9F61BWW457	7.5	95	202
9F61CGL210	15.5	C/2.00"	15"	9F61BNW746	9F61BWW457	15	110	205
9F61CGN210	15.5	C/2.00"	15"	9F61BNW746	9F61BWW457	34.5	200	210
9F61CHM210	25.8	C/2.00"	21"	9F61BNW746	9F61BWW457	23	150	208
9F61CEF310	2.75/5.5/8.25	D/3.00"	12"	9F61BNW747	9F61BWW459	7.5	95	202
9F61CGL310	15.5	D/3.00"	15"	9F61BNW747	9F61BWW459	15	110	205
9F61CHM310	25.8	D/3.00"	21"	9F61BNW747	9F61BWW459	23	150	208
9F61CJN310	38	D/3.00"	27"	9F61BNW747	9F61BWW459	34.5	200	210
9F61CEF410	2.75/5.5/8.25	DD/3.00"	12"	9F61BNW748	-	7.5	95	202
9F61CGL410	15.5	DD/3.00"	15"	9F61BNW748	-	15	110	205
9F61CHM410	25.8	DD/3.00"	21"	9F61BNW748	-	23	150	208
9F61CJN410	38	DD/3.00"	27"	9F61BNW748	-	34.5	200	210

Refer to drawings for specific dimensions.

ACCESSORIES AND SPARE PARTS

Hinge Trunions and Operating Eyes for Use on Disconnecting Switches

Fuse Size	Hinge Trunion Model No.	Operating Eye Model No.
C	9F61BJW397	9F61BFW394
D	9F61BKW398	9F61AWW612
DD	9F61BLW399	9F61AWW612



EK-3C
9F61BFW394



EK-3D and DD
9A61AWW612



EKO-3C
9F61BJW397



EKO -3D
9F61BKW398



EKO-3DD
9F61BLW399

FUSE SIZE B (FERRULE DIAMETER 1.5625")

Fuse Supports & Disconnect Switches	Spare Live Parts(*)	Figure (Fig.)	Spare Fuse Clips(**)	Figure (Fig.)	Fuse size
9F61ABB101	9F61BNW450		9F61BWW460		B
9F61ABG101					B
9F61ADG101					B
9F61ADJ101					B

FUSE SIZE C (FERRULE DIAMETER 2")

Fuse Supports & Disconnect Switches	Spare Live Parts(*)	Figure (Fig.)	Spare Fuse Clips(**)	Figure (Fig.)	Fuse size
9F61AAB201	9F61BNW451		9F61BWW457		C
9F61ACB201					C
9F61AEG201					C
9F61AGG201					C
9F61AGJ201					C
9F61AAB205	9F61BNW731				C
9F61ACB205					C
9F61AEG205					C
9F61AGG205					C
9F61AGJ205					C
9F61AHM201	9F61BNW743				C
9F61CEF209					C
9F61CGL209					C
9F61CHM209					C
9F61AHM205	9F61BNW746				C
9F61CEF210			C		
9F61CGL210			C		
9F61CHM210			C		

(*) Spare Live Parts: Order (1) Live Parts for each Fuse Support and Disconnecting Switch (includes live parts for both ends).

(**) Fuse Clips: Order (2) Fuse Clips for each Fuse Support and order (1) Fuse Clip for each Disconnecting Switch.

FUSE SIZE D (FERRULE DIAMETER 3")

Fuse Supports & Disconnect Switches	Spare Live Parts(*)	Figure (Fig.)	Spare Fuse Clips(**)	Figure (Fig.)	Fuse size
9F61AAB305	9F61BNW732		9F61BWW459		D
9F61AEB305					D
9F61AEG305					D
9F61AGG305					D
9F61AGJ305					D
9F61AHM301	9F61BNW744				D
9F61CEF309					D
9F61CGL309					D
9F61CHM309					D
9F61CJN309					D
9F61AHM305	9F61BNW747				D
9F61CEF310					D
9F61CGL310					D
9F61CHM310					D
9F61CJN310					D
9F61AAB301	9F61BNW750		D		
9F61AEB301			D		
9F61AEG301			D		
9F61AGG301			D		
9F61AGJ301			D		



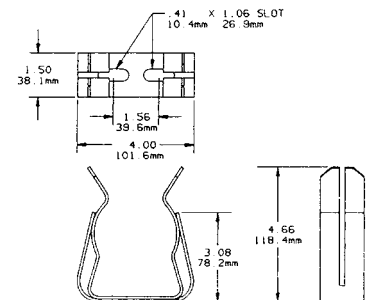

(*) Spare Live Parts: Order (1) Live Parts for each Fuse Support and Disconnecting Switch (includes live parts for both ends).

(**) Fuse Clips: Order (2) Fuse Clips for each Fuse Support and order (1) Fuse Clip for each Disconnecting Switch.

For the 3" ferrule diameter we also offer the Cat # 228-700-530 clips. These spring reinforced clips will accommodate one and two barrel 3-inch diameter medium voltage ferrule type fuses. The clip and reinforcing spring are intended to be bolted to a copper busbar through two .41" and 1.06" slots. A minimum copper-bus section of 1/4" x 1-1/2" is recommended for maximum ratings of 24R and 450E. The Cat # 228-700-530 is for one pair of clips, enough for one fuse.



FUSE SIZE DD (FERRULE DIAMETER TWO 3" IN PARALLEL)

Fuse Supports & Disconnect Switches	Spare Live Parts(*)	Figure (Fig.)	Spare Fuse Clips(**)	Fuse size
9F61AHM401	9F61AWW738		N/A	DD
9F61CEF409				DD
9F61CGL409				DD
9F61CHM409				DD
9F61CJN409				DD
9F61AAB405	9F61BNW461		N/A	DD
9F61AEB405				DD
9F61AEG405				DD
9F61AGG405				DD
9F61AGJ405				DD
9F61AHM405	9F61BNW748		N/A	DD
9F61CEF410				DD
9F61CGL410				DD
9F61CHM410				DD
9F61CJN410				DD
9F61AAB401	9F61BNW751		N/A	DD
9F61AEB401				DD
9F61AEG401				DD
9F61AGG401				DD
9F61AGJ401				DD

CONVERSION KIT D TO DD FOR USE ON FUSE SUPPORTS

Model No.	Figure (Fig.)	Used on live parts	Figure (Fig.)
9F61BNW402		9F61BNW751 (Indoor)	
		9F61AWW738 (Outdoor)	

FUSE SIZE EE (FERRULE DIAMETER TWO 4" IN PARALLEL)

Fuse Supports & Disconnect Switches	Spare Live Parts(*)	Figure (Fig.)	Spare Fuse Clips(**)	Fuse size
9F61AFB501	9F61BNW452		N/A	EE
9F61AFG501				EE
9F61AFJ501				EE

(*) Spare Live Parts: Order (1) Live Parts for each Fuse Support and Disconnecting Switch (includes live parts for both ends).
(**) Fuse Clips: Order (2) Fuse Clips for each Fuse Support and order (1) Fuse Clip for each Disconnecting Switch.

CL-14 Fuses

Clip-Lock Clips

FUSE BLOCKS & HOLDERS



228-700-520 (One pair of clips)

The clip lock design provides a reliable, high-pressure contact. Mersen CL-14 fuses have copper tabs which slide into position between the clip casting and cam. When the cam is locked by moving the pull ring, a high-pressure contact is made between the clip casting and fuse tab. Each clip includes two .44" diameter counter-sunk holes on 2" centers and two flat head socket screws (3/8-16 UNRC, recommended torque 200 pound-inches) for mounting the clip on standard NEMA insulators. Order catalog number 228-700-520 (for one pair of fuse clips, enough for one fuse).

Mounting Details for Clip Lock Cat. No. 228-700-520

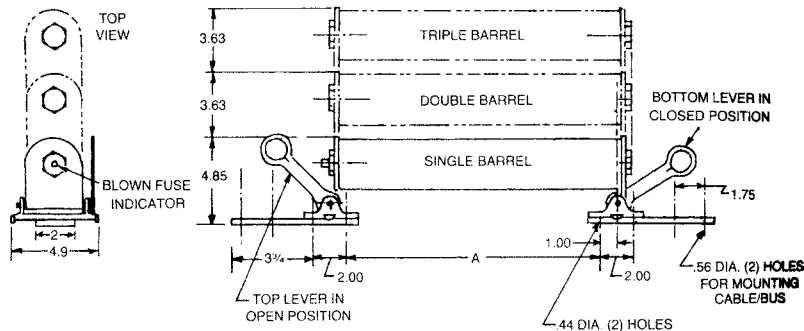

CATALOG NUMBERS, DIMENSIONS

CL-14 Fuse Catalog No.	A Dimensions - Inches
A055C1D0R0-(10E-150E)	13.25
A055C1D0R0-(200E-400E)	19.25
A055C2D0R0-(450E-600E)	19.25
A155C1D0R0-(10E-50E)	16.25
A155C1D0R0-(65E-100E)	19.25
A155C2D0R0-(125E)	19.25
A155C3D0R0-(150E-300E)	19.25

FB

P243/P266/P292

Fuse Blocks

FUSE BLOCKS & HOLDERS

FUSE BLOCKS FOR SEMICONDUCTOR FUSES



Mersen P243 and P266 series fuse blocks for Form 101 fuses are glass-filled polycarbonate or laminated phenolic insulator blocks with studs to accommodate bolt-in fuses. The P292 series has a laminated phenolic insulator base with fuse clips. All studs, clips and mounting hardware are tin or zinc plated.

DIMENSIONS

For Use with	Amps	Catalog No.	Fig.	Dimensions - Inches						Stud Size	Torque (in lbs)
				A	B	C	D	E	F		
A13X, A15QS	70-450	P243D	2	4.40	1.50	2.79	2.20	2.06	1.17	1/4-20	36
A13X, A15QS	500-600	P243G	2	4.40	1.50	2.79	2.20	2.44	0.98	5/16-18	84
A25X, A25Z, A30QS	35-60	P243G	2	4.40	1.50	2.79	2.20	2.44	0.98	5/16-18	84
A25X, A25Z, A30QS	70-200	P243	1	4.50	1.50	2.50	2.25	2.38	1.06	1/4-20	36
A25X, A25Z, A30QS	225-600	P243G	2	4.40	1.50	2.79	2.20	2.44	0.98	5/16-18	84
A50P	35-60	P243G	2	4.40	1.50	2.79	2.20	2.44	0.98	5/16-18	84
A50P, A50QS	70-200	P243E	2	4.40	1.50	2.79	2.20	2.88	0.76	1/4-20	36
A50P, A50QS	225-600	P266C	1	6.00	2.00	3.00	3.00	3.28	1.36	3/8-16	180
A60X, A60Z, A70QS-4	35-200	P243C	2	4.40	1.50	2.79	2.20	3.62	0.39	1/4-20	36
A60X, A60Z, A70QS-4	225-600	P266A	1	6.00	2.00	3.00	3.00	4.06	0.97	3/8-16	180
A70P, A70Q	35-100	P243C	2	4.40	1.50	2.79	2.20	3.62	0.39	1/4-20	36
A70P, A70Q	125-200	P266A	1	6.00	2.00	3.00	3.00	4.06	0.97	3/8-16	180
A70P, A70Q	225-400	P266A	1	6.00	2.00	3.00	3.00	4.06	0.97	3/8-16	180
A70QS-4K	125-200	P266A	1	6.00	2.00	3.00	3.00	4.06	0.97	3/8-16	180
A70P, A70Q, A70QS-4K	450-600	P266F	1	8.00	2.50	3.00	4.00	5.09	1.45	3/8-16	180
A100P	35-100	P266G	1	6.00	2.00	2.50	3.00	4.25	0.88	1/4-20	36
A100P	125-400	P266L	1	6.00	2.00	3.00	3.00	4.66	0.67	3/8-16	180
A120X	1-30	P292	3	-	-	-	-	-	-	-	-
A30QS	700-800	FH25F4	1	6.00	2.00	3.00	3.00	2.66	1.67	3/8-16	144
A50QS	700-800	FH50F4	1	8.00	2.50	3.00	4.00	4.21	1.84	1/2-13	360
A50QS	900-1000	FH50F5	1	8.00	2.50	3.00	4.50	4.97	1.50	1/2-13	360
A70QS-4K	450-600	FH70F3	1	8.00	2.50	3.00	4.00	5.09	1.91	1/2-13	360

Note: FH Blocks are 1" thick.

* Not UL or CSA Certified

RATINGS:

- **Amps:** 1 to 1000A
- **Clip Type:** 1200VAC or less
- **Stud Type:** 1000VAC or less

APPROVALS:

- UL Recognized Component guide IZLT2 File E52283
- CSA Certified C22.2, class 6225, File 32169

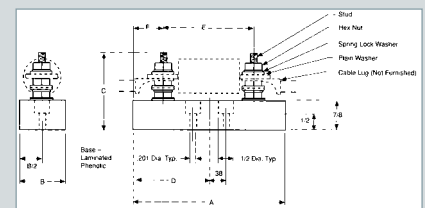

Figure 1

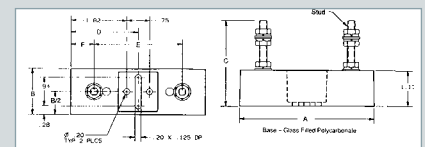

Figure 2

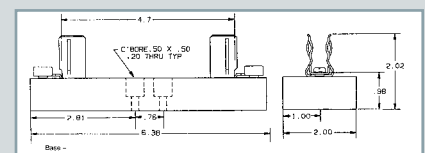

Figure 3

1SC/1MSC

Modular Semiconductor Fuse Blocks

FUSE BLOCKS & HOLDERS



Mersen 1SC and 1MSC semiconductor fuse blocks feature modular mounting that offers greater flexibility in adjusting to various fuse lengths. Both stud type and integral box connector versions are offered to allow for user preference of wire terminations. The integral box connector versions also provide for greater heat dissipation. Mounting hardware is supplied with the blocks.

RATINGS:

1SC

- **Volts:** 1000V
- **Amps:** 800A Maximum
- **SCCR:** 200kA

1MSC

- **Volts:** 600V
- **Amps:** 600A Maximum
- **SCCR:** 200kA

APPROVALS:

- UL Recognized Component File for 1SC: E52283
File for 1MSC: E35113



FB

DIMENSIONS

Catalog No.	Voltage Rating	Ampere Rating	Pkg.	UR	Type	Connector		Hardware		Tightning Torque (lb.-in.)			Fig.
						Wire Range		Bolt	Washer	Cable	Fuse	Mounting	
1SC250	1,000	400	Pair	Yes	1/4" Stud	—	—	—	—	60	60	25	1
1SC375	1,000	800	Pair	Yes	3/8" Stud	—	—	—	—	190	190	50	2
1MSC101	600	100	Each	Yes	Al Box	Al/Cu 2/0 - #6	1/4"	0.655"	120	70	25	3	
1MSC102	600	400	Each	Yes	Al Box	Al/Cu (2) 250kcmil - #6	1/4"	0.655"	275	120	25	4	
1MSC103	600	400	Each	Yes	Al Box	Al/Cu (2) 250kcmil - #6	3/8"	0.900"	275	120	25	5	
1MSC104	600	600	Each	Yes	Al Box	Al/Cu (2) 500kcmil - #6	3/8"	0.900"	375	170	25	6	
1SCM8	1,000	400	Pair	Yes	M8 Stud	—	—	—	—	60	60	25	1
1SCM10	1,000	800	Pair	Yes	M10 Stud	—	—	—	—	190	190	50	2

All part numbers are sold in pairs

*Consult Factory

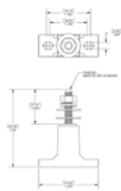

Figure 1

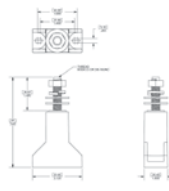

Figure 2

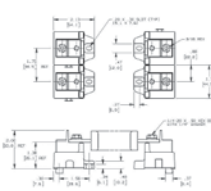

Figure 3

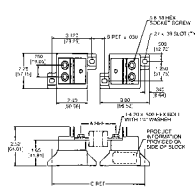

Figure 4

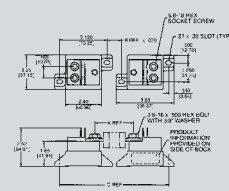

Figure 5

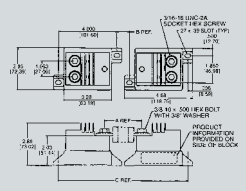

Figure 6

703, U705, U710

Semiconductor Fuse Holders

FUSE BLOCKS & HOLDERS

750V SEMICONDUCTOR FUSE HOLDERS



Mersen semiconductor fuse holders feature open face styles. Each version is rated 750 volts and accommodates 14 x 51 mm or 22 x 58 mm fuses. 703, U705 and U710 holders feature Mersen's unique adder-block design which can be snapped onto 1-, 2-, or 3-pole blocks to form multi-pole segmented blocks of as many poles as desired. A choice of box, screw or pressure plate connectors is offered to fit a wide range of standard or solid copper wire. All versions have verified dielectric strengths in excess of 2500V. A patented built-in DIN-rail adapter on the U710 blocks adds further design versatility. All fuse clips are made of high conductivity tin-plated copper with spring reinforced clips.

RECOMMENDED FUSE USAGE:

- 703 use with 14x51mm A70QS, A70P, URD
- U705 use with 14x51mm A70QS, A70P, URD
- U710 use with 22x58mm A70QS, URD, up to 100A

HIGHLIGHTS:

- Thermoplastic bases
- DIN-rail (U710) or Screw Mount
- Adder block design

APPLICATIONS:

- All circuits up to 750 volts using semiconductor fuses for protection of small inverters, UPS systems, motor drives, etc.

RATINGS:

- **Volts:** 750V
- **Amps:** 30A (703), 50A (U7050), 100A (U7100)
- **SCCR:** 200kA dependent on fuse I.R.

APPROVALS:

- UL Recognized component guide IZLT2, File E52283
- CSA Certified class 6225, File 32169



750 VOLT FUSE HOLDERS FOR 14 X 51MM & 22 X 58 MM FUSES

Catalog No.	Fuse Size	Ampacity Rating	Poles	Connector Type	Wire Range	Figure	Connector Torque (In-Lb)
U70505	14 x 51	50	Adder	Box	Al/Cu #2-14	1	35
U70506			1				
U70507			2				
U70508			3				
70315	14 x 51	30	Adder	Screw	Cu #10-14	1	20
70316			1				
70317			2				
70318			3				
70325	14 x 51	30	Adder	Pressure Plate	Cu #10-14	1	20
70326			1				
70327			2				
70328			3				
70355	14 x 51	30	Adder	Box	Cu* #4-14	1	35
70356			1				
70357			2				
70358			3				
U71005	22 x 58	100	Adder	Box	Al/Cu #2-14	5	35
U71006			1				
U71007			2				
U71008			3				

*Copper box connectors and clips-for copper wires only.

Note: To convert 30A adder pole to single pole, use end barrier #U09322 100A adder pole to single pole, use end barrier #U09372.

Recommended mounting screws; #10 (.190" dia)

DIMENSIONS

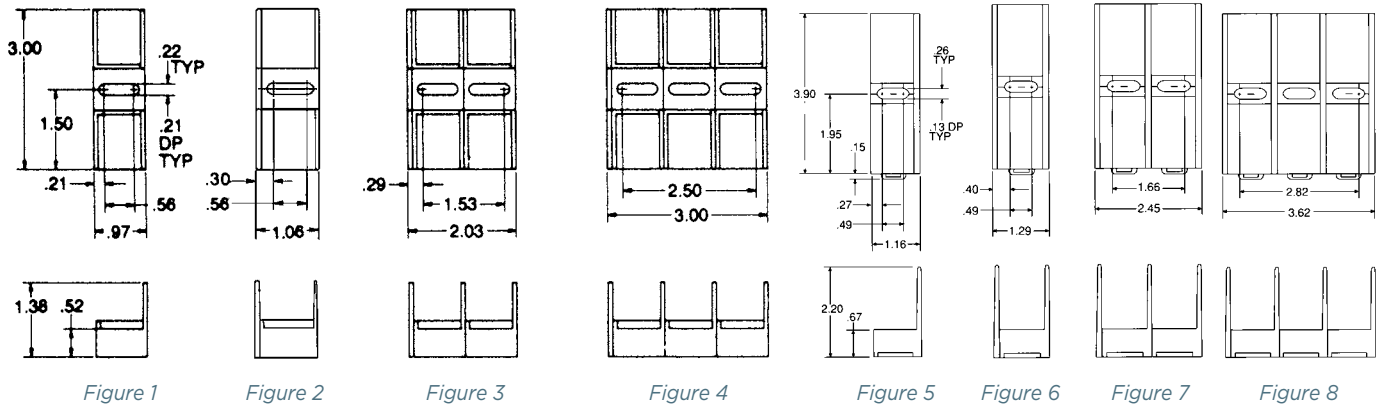

PS 20x127

Ferrule Fuse Holders and No-Load Disconnectors

FUSE BLOCKS & HOLDERS

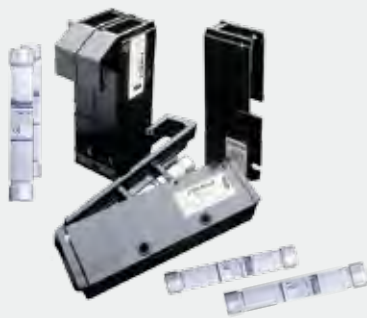

RATINGS:

- **Volts:** 1,500V, 2,500V
- **SCCR:** 42kA AC, 55kA DC

APPROVALS:

- UL Recognized component
File E113357



HIGHLIGHTS:

- Solid assembly offers good thermal and mechanical withstand rating
- Fuse mounting in holders or no-load disconnectors with or without open fuse indicating microswitches
- Phenolic resin models for basic applications, fiber-glass polyester for applications in corrosive atmospheres or applications for traction
- Voltage = 1,500 V and 2,500 V

DIELECTRIC WITHSTAND TESTS

	R.M.S. voltage 1 mn 50/60 Hz	Impulse voltage 1.2/50 s (IEC 694 et CEI 60)
Between close phases and phase and ground	6kV(1) - 10 kV(2)	12 kV(1) - 20 kV(2)
Between phases and microswitch	12 kV	

Connecting with 16mm² max. width, 5mm max. thick terminal

(1) Basic model

Max. temperature (°C)/ Relative humidity (%): 20 °C/95% - 40°C/80% - 50°C/50%

(2) Salt spray-proof model

Moist tropical and equatorial climate or corrosive atmosphere.

Connecting with 50 mm² max. cable with copper terminals or with a 15 x 8 max. rigid or flexible bar.

DIMENSIONS

Description	Insulation voltage rating Ui AC 50/60 Hz or DC	Fuse current rating I _n (A)	Maximum operating current of fuse (A)					Advised copper wire size mm ²	Fire and fumes class NF F 16-101 and 102 and UL
			1000 V gLB	=1000 V gRC	=1000 V gRB	=1500 V gRB	=1500 V gRD		
PSI 20X127	1500 V without terminal covers	50		50				10	basic model 12-F1 UL 94 V1 salt spray-proof model I1 - F1 UL 94 V0
PSI 20X127 PRE	2500 V with terminal covers and only salt spray-proof model	63	80	56			16		
PSII 20X127 PRE		80	90		No Operating Limit		25		
PSIII 20X127 PRE		100	100			35			
PSIV 20X127 PRE		125				50			

FUSE HOLDERS AND ACCESSORIES

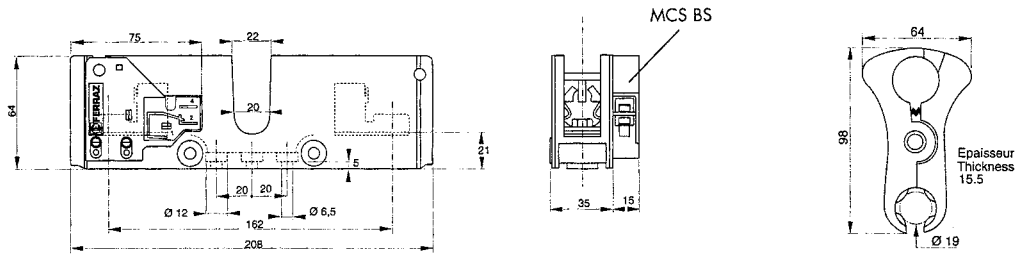

Description	Catalog No.	Weight [g]	Packaging
PSI 20x127	X 097310	260	3 pieces
PSI 20x127 + MCS BS	X 220130	290	2 pieces

PMCP 20+22
Catalog #: K 100036
Weight: 40g
Packaging: 1

FUSE NON-LOAD DISCONNECTORS AND ACCESSORIES

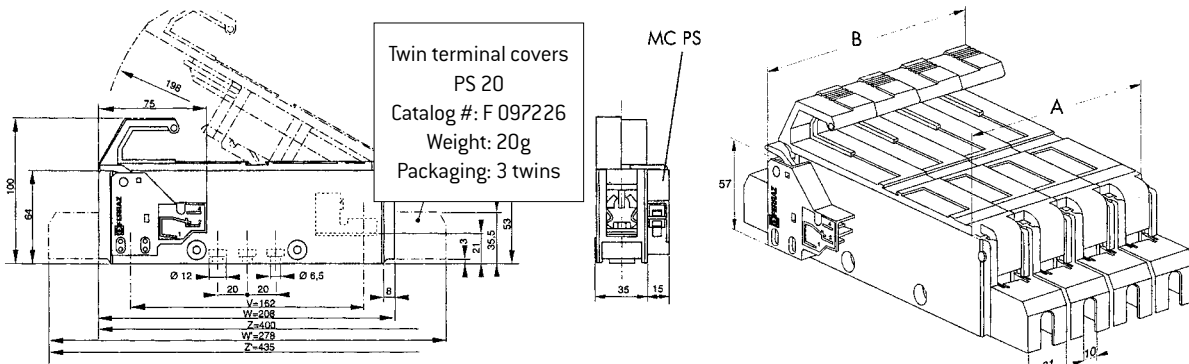

V: Connecting distance between centers
W: Clip for rail mounting in two positions
W': With terminal cover length
Y: Space factor with a 90° fuse carrier position

Z: Without terminal cover, space factor with a 180° fuse carrier position
Z': With terminal cover, space factor with 180° fuse carrier position

Description (basic model)	Catalog No.
PSI 20x127 PRE	F097203
PSII 20x127 PRE	G097227
PSIII 20x127 PRE	H097228
PSIV 20x127 PRE	J097229
PSI 20 x 127 PRE+MC PS	H097205
PSII 20 x 127 PRE+MC PS	D097293
PSIII 20 x 127 PRE+MC PS	E097294
PSIV 20 x 127 PRE+MC PS	F097295

No. of Poles	A	B
1	35	50
2	69	84
3	103	118
4	137	152

Preisolating and blown fuse indicating microswitch features	
Microswitch rated current	Non-inductive circuit interrupting rating
3A - 50 Hz	3A - 50 Hz
3A - DC	3A - DC

Reliable minimum operating voltage/
current: 10V - 10mA
Connecting with 6.35 mm lug

Description (salt spray-proof model)	Ref. No.
PSI 20x127 PRE BS	G097204
PSII 20x127 PRE BS	L097231
PSIII 20x127 PRE BS	T097261
PSIV 20x127 PRE BS	C097292
PSI 20 x 127 PRE BS+MC PS	J097206
PSII 20 x 127 PRE BS+MC PS	G097296
PSIII 20 x 127 PRE BS+MC PS	H097297
PSIV 20 x 127 PRE BS+MC PS	J097298

Distances when mounting on a conductive board @ Ui = 2500 VAC

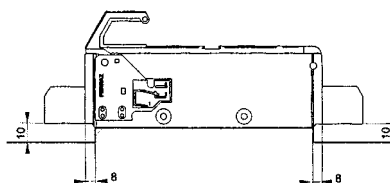

FB

Miniature Fuse Blocks

5X20QC1 & 6X32QC1 Single Pole Fuse Blocks

FUSE BLOCKS & HOLDERS



FB

The 5X20QC1 single pole fuse blocks are for for 5 mm x 20 mm fuses featuring tin-plated clips, a polyester insulator and 3/16" quick-connect terminals. The 6X32QC1 single pole fuse blocks are for 1/4" x 1-1/4" fuses and have tin-plated phosphor bronze clips, a phenolic insulator and 1/4" quick-connect terminals.

RECOMMENDED FUSE USAGE:

- 5X20QC1 use with GGM, GGA, GSA, GSB, GDG
- 6X32QC1 use with GSA, GDL, GGC, GAB

DIMENSIONS:

5X20QC1

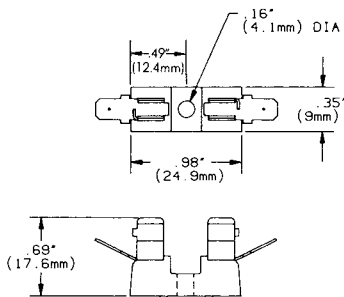

6X32QC1

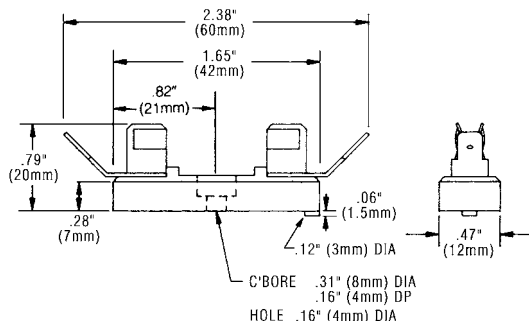

RATINGS:

5X20QC1:

- **Volts:** 250V
- **Amps:** 15A

6X32QC1:

- **Volts:** 250V
- **Amps:** 30A

FEATURES/BENEFITS:

5X20QC1

Single Pole Fuse Block for 5 mm x 20 mm fuses

- Tin plated clips
- Polyester insulator
- 3/16" quick-connect terminals
- Rated 15A, 250V
- UL recognized

6X32QC1

Single Pole Fuse Block for 1/4" x 1-1/4" fuses

- Tin plated phosphor bronze clips
- Phenolic insulator
- 1/4" quick-connect terminals
- Rated 30A, 250V - UL Recognized

APPROVALS:

- UL Recognized



GPM Series

Panel Mount Fuse Holders

FUSE BLOCKS & HOLDERS



Mersen GPM panel mount fuse holders are in sizes to accommodate Class CC and midget (1-1/2" x 13/32") fuses. All 30A holders have PET insulators for extra dependability and trouble-free installation. Patented design allows same body to accept screw or bayonet knob. Flange design allows front or rear mounting.

CATALOG NUMBERS & DESCRIPTIONS

Catalog No.	Fig.	Cap Type	Amps	Volts	Fuse Type	Terminal Type
GPM-S	1	Screw Knob	30	600	1-1/2" x 13/32"	1/4" Quick-connect/Solder
GPM-S90	2	Screw Knob	30	600	1-1/2" x 13/32"	1/4" Quick-connect/Solder, Right Angle
GPM-SRR	1	Screw Knob	30	600	Class CC	1/4" Quick-connect/Solder
GPM-SRR90	2	Screw Knob	30	600	Class CC	1/4" Quick-connect/Solder, Right Angle
GPM-B	1	1/4 Turn Bayonet Knob	30	600	1-1/2" x 13/32"	1/4" Quick-connect/Solder
GPM-B90	2	1/4 Turn Bayonet Knob	30	600	1-1/2" x 13/32"	1/4" Quick-connect/Solder, Right Angle
GPM-BRR	1	1/4 Turn Bayonet Knob	30	600	Class CC	1/4" Quick-connect/Solder
GPM-BRR90	2	1/4 Turn Bayonet Knob	30	600	Class CC	1/4" Quick-connect/Solder, Right Angle
GPM-WT	1	Water-tight Screw Knob	30	600	1-1/2" x 13/32"	1/4" Quick-connect/Solder
GPM-WT90	2	Water-tight Screw Knob	30	600	1-1/2" x 13/32"	1/4" Quick-connect/Solder, Right Angle
GPM-WTR	1	Water-tight Screw Knob	30	600	Class CC	1/4" Quick-connect/Solder
GPM-WTR90	2	Water-tight Screw Knob	30	600	Class CC	1/4" Quick-connect/Solder, Right Angle

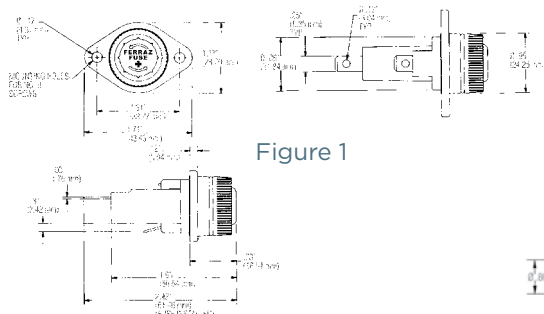
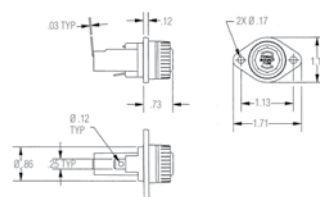

Figure 1

Figure 2



RATINGS:

- **Volts:** 600VAC / DC
- **Amps:** 30A Maximum
- **SCCR:** 200kA (Class CC Fuses); 100kA (Midget Fuses)

RECOMMENDED FUSE USAGE:

GPM Fuse Holders will accommodate these Mersen fuses:

GPM-SRR, GPM-BRR, GPM-WTR: ATQR, ATDR, ATMR,

GPM-SRR90, GPM-BRR90, GPM-WTR90: ATQR, ATDR, ATMR,

GPM-S, GPM-B, GPM-WT: ATQ, ATM, TRM, OTM, GGU, A13X-2, A25Z-2, A60Q-2, A6Y-2B, **GPM-S90, GPM-B90, GPM-WT90:** ATQ, ATM, TRM, OTM, GGU, A13X-2, A25Z-2, A60Q-2, A6Y-2B

APPROVALS:

- UL Recognized, guide IZLT2, File E52283
- CSA Certified - C22.2, class 6225, File 32169



Mersen GPM panel mount fuse holders will accommodate 1/4" x 1-1/4" 3AG fuses and 5 mm x 20 mm fuses; most are approved by U.L. and CSA. Cap and body material is bakelite or polycarbonate and function as a screw-in or bayonet style closure. Finger-grip or screwdriver slots are available. All holders are rated for up to 250 volts with amp ratings ranging from 3A to 15A.

Catalog No.	Cap Type	Volts	Amps	Fuse Size	Terminal Type	Approvals
GPM-A	Finger-grip/Screw-in	250	10	5mm x 20mm	Solder	UR/CSA
GPM-A1	Finger-grip/Screw-in	250	10	5mm x 20mm	Solder	
GPM-A2	Finger-grip/Screw-in	250	10	5mm x 20mm	Solder	UR/CSA
GPM-A3	Finger-grip/Screw-in	250	3	5mm x 20mm	Solder	UR/CSA
GPM-A4	Finger-grip/Screw-in	250	6.3	5mm x 20mm	Solder, right angle	
GPM-A5	Screwdriver Slot	250	10	5mm x 20mm	Solder	
GPM-A6	Screwdriver Slot	250	6.3	5mm x 20mm	Solder, right angle	UR/CSA
GPM-A8	Screwdriver Slot	250	10	5mm x 20mm	Solder, right angle	UR/CSA
GPM-A9	Screwdriver Slot	250	6.3	5mm x 20mm	Solder, right angle	UR/CSA
GPM-A10	Screwdriver Slot	250	6.3	5mm x 20mm	3/16" Solder/QC	UR/CSA
GPM-A11	Screwdriver Slot	250	10	5mm x 20mm	Solder, right angle	UR/CSA

RECOMMENDED FUSE USAGE:

- GPM-A: GGM, GGA, GSB, GSC, GDG, GSD, GSF
- All dimensions mm's

FB



GPM-A



GPM-A1

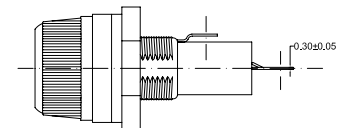
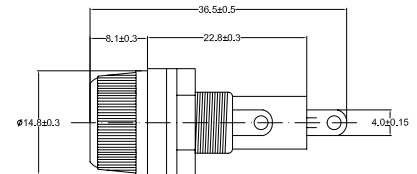
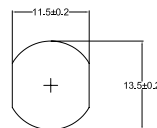
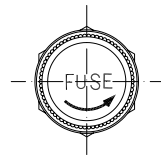
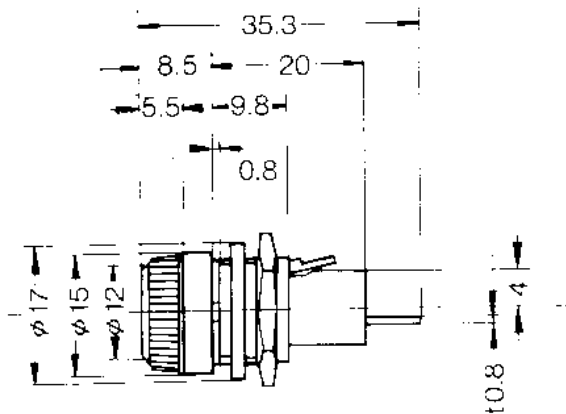



GPM-A2

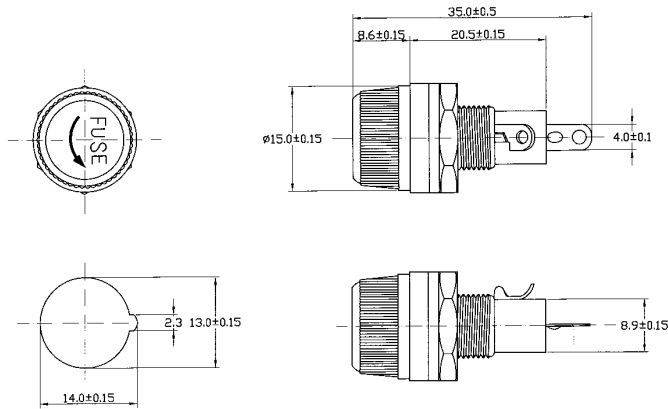

GPM-A3

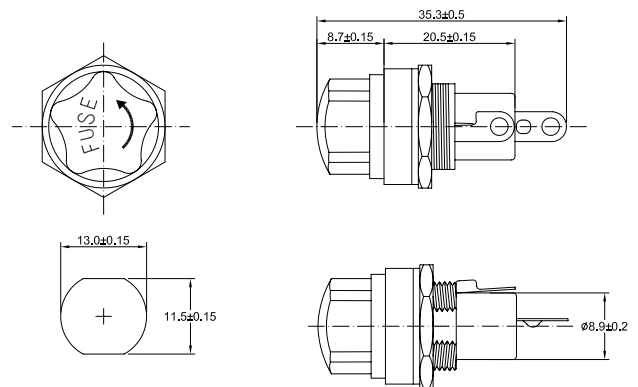

GPM-A4

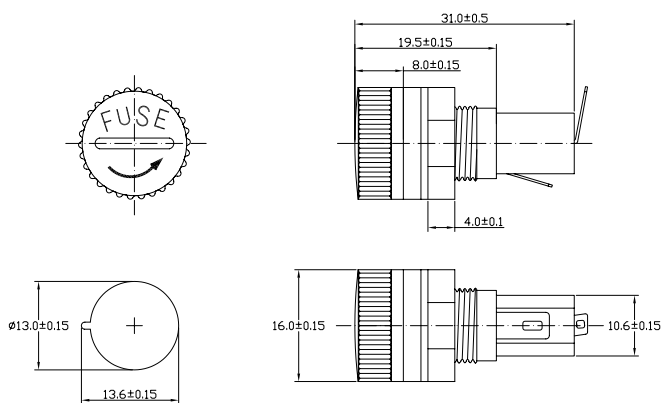

GPM-A5

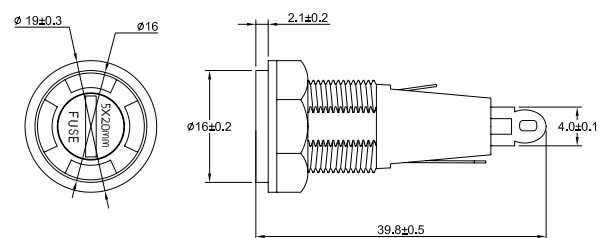

FB



GPM-A6

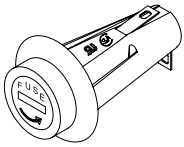
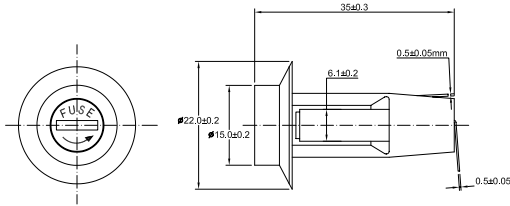
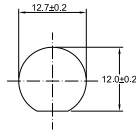

GPM-A8

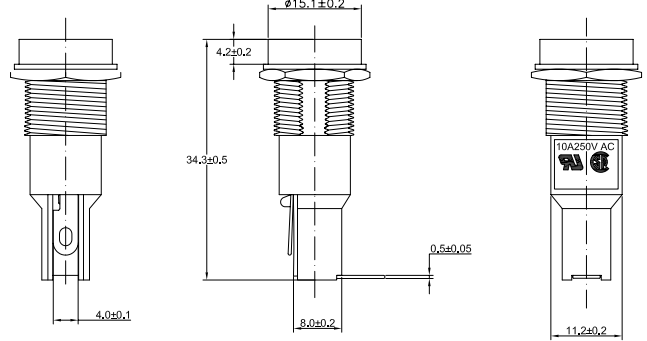
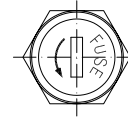

FB



GPM-A9

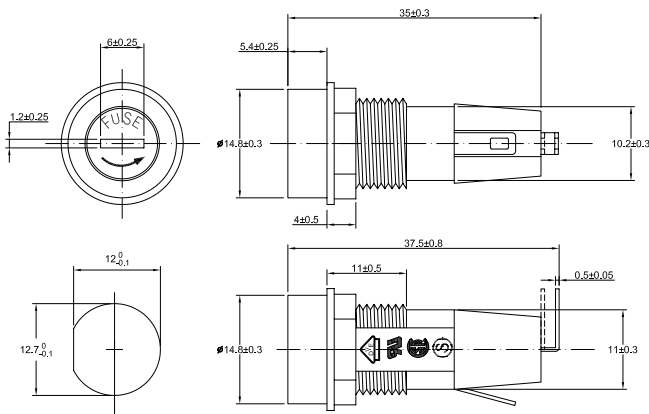

GPM-A10

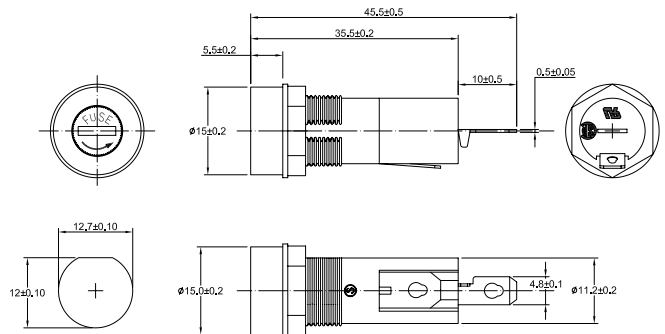



GPM-A11

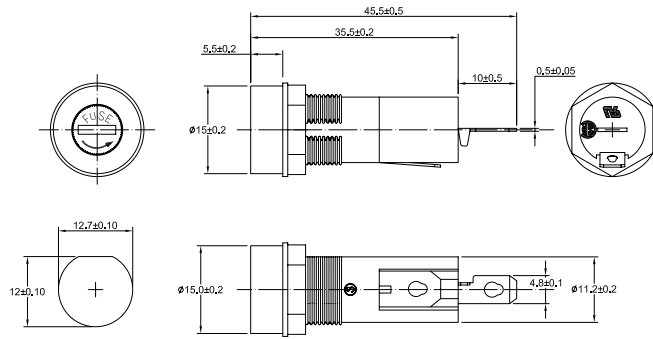

Catalog No.	Cap Type	Volts	Amps	Fuse Size	Terminal Type	Approvals
GPM-G	Finger-grip/Screw-in	250	15	3AG	3/16" Solder/QC	UR/CSA
GPM-G1	Finger-grip/Screw-in	250	10	3AG	3/16" Solder/QC	UR/CSA
GPM-G2	Finger-grip/Screw-in	250	10	3AG	Solder	
GPM-G3	Screwdriver Slot	250	10	3AG	Solder	UR/CSA
GPM-G5	Finger-grip/Bayonet	250	10	3AG	1/4" Solder/QC	UR/CSA
GPM-G6	Finger-grip/Bayonet	250	10	3AG	Solder	UR/CSA
GPM-G7	Screwdriver Slot	250	15	3AG	3/16" Solder/QC	UR/CSA

RECOMMENDED FUSE USAGE:

GPM-G: GGC, GDL, GSA, GAB
All dimensions mm's



GPM-G



GPM-G1

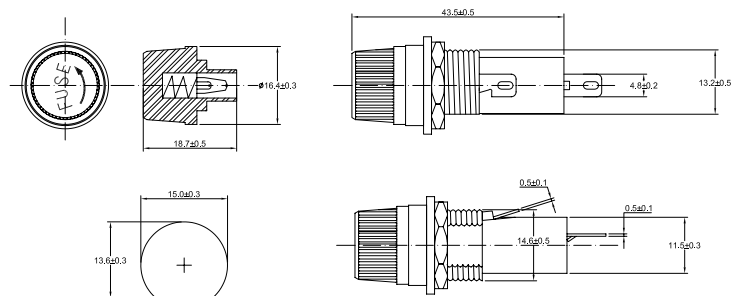
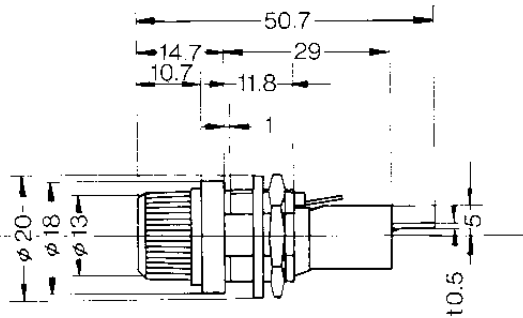

FB



GPM-G2

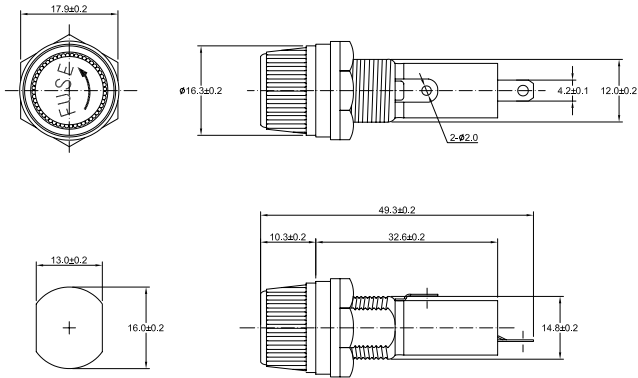

GPM-G3

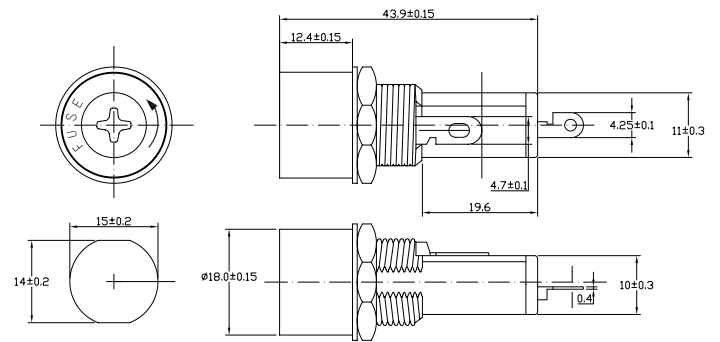

GPM-G5

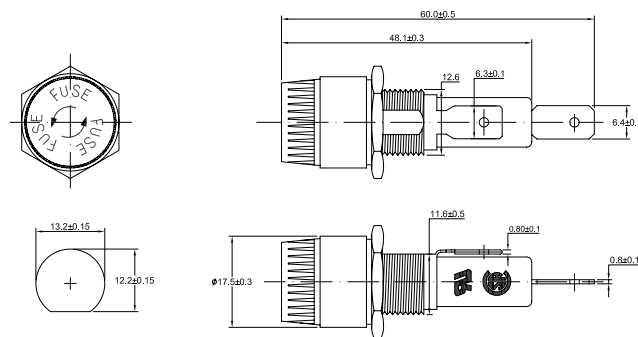

GPM-G6

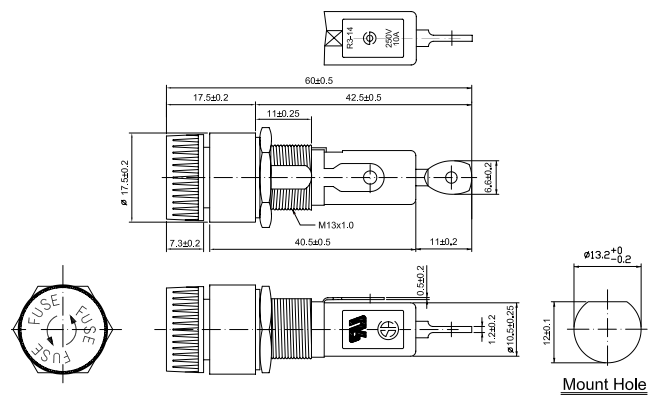

FB



GPM-G7

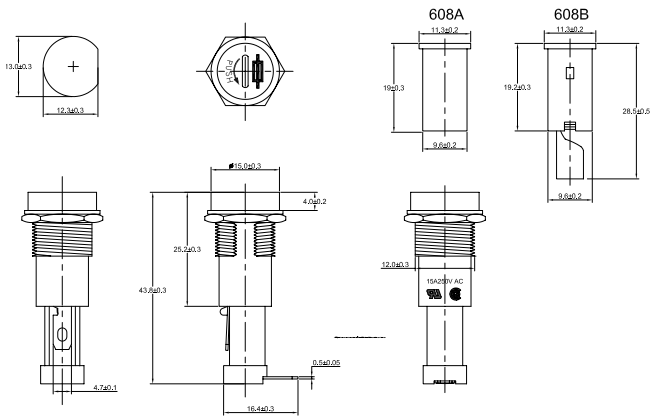

GPM-G8

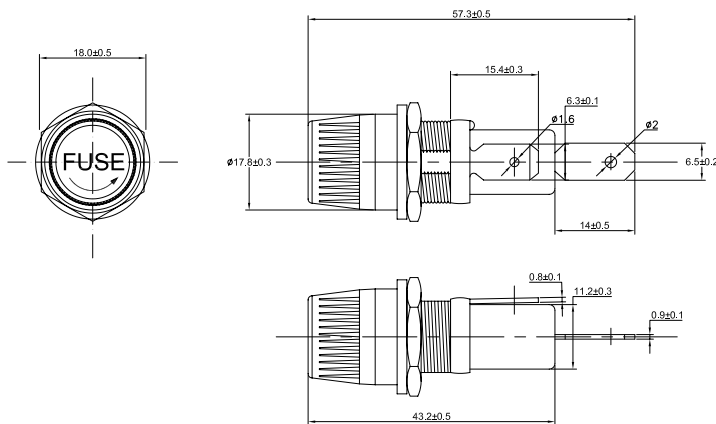

FB

DFC Series

Dead-Front Fuse Covers

FUSE BLOCKS & HOLDERS



Mersen DFC dead-front fuse covers snap on to individual fuses installed in fuse blocks, covering exposed live clips and terminals and reducing accidental contact by personnel. They are sized to fit Class G, H, J, K, R, CC or midget fuses for increased safety and (optional) open-fuse indication. All DFC dead-front fuse covers are reusable when a fuse is replaced – simply detach from the open fuse and re-attach to the new replacement fuse. On indicator models an orange indicator light will illuminate to indicate an open fuse. DFC fuse cover ends can be easily cut to accommodate existing wiring, safety switches or special installations. A blank label is provided with each DFC to write in circuit or fuse information.

FEATURES/BENEFITS:

- Innovative design provides dead-front electrical safety to personnel
- Optional orange indicator light shows open fuse
- Many sizes to fit virtually all popular fuses/fuse blocks
- Reusable with no changes or additional cost
- Labels provided for write-in identification
- Thermoplastic flammability rating of UL 94-V2
- Low leakage current <0.6 mA at 600V

RATINGS:

Non-Indicating

- **Volts:** 0 to 600VAC/DC
- **Amps:** Fits fuses rated 0 to 200A

Indicating

- **Volts:** 90 to 600VAC, 115 to 600VDC
- **Amps:** Fits fuses rated 0 to 200A

APPROVALS:

- UL Listed (All except midget size) guide JDVS, File E90426
- UL Recognized Component (midget) guide JDVS2, File E90426
- CSA Certified class 6228, File 70159



CATALOG NUMBERS & DIMENSIONS

Catalog Numbers		Fuses Accomodated			Dimensions (inches)		
Non-indicating	indicating	Amps	Volts	Class	A	B	C
DFC-1	DFC-1I	0-30	600	J	4.68	1.36	1.97
DFC-2	DFC-2I	0-30	600	R, K, H	7.45	1.35	1.80
DFC-3	DFC-3I	65-100	600	J	7.57	1.30	2.20
DFC-4	DFC-4I	65-100	250	R, K, H	8.73	1.40	2.02
DFC-5	DFC-5I	35-60	600	R, K, H	7.46	1.35	2.00
DFC-6	DFC-6I	35-60	600	J	4.64	1.40	2.17
DFC-7	DFC-7I	0-30	600	Midget, CC, G	3.71	0.69	1.37
DFC-8	DFC-8I	65-100	600	R, K, H	10.55	1.55	2.26
DFC-9	DFC-9I	0-30	250	R, K, H	3.71	0.85	1.55
DFC-10	DFC-10I	0-30	600	SJ	4.56	1.06	2.02
DFC-11	DFC-11I	65-100	600	SJ	5.52	1.7	2.04
DFC-12	DFC-12I	110-200	600	J	6.63	3.03	2.86
DFC-13	DFC-13I	35-60	250	R, K, H	5.20	1.12	1.92

WARNING: To avoid electrical shock, TURN POWER OFF before installing, removing or servicing.

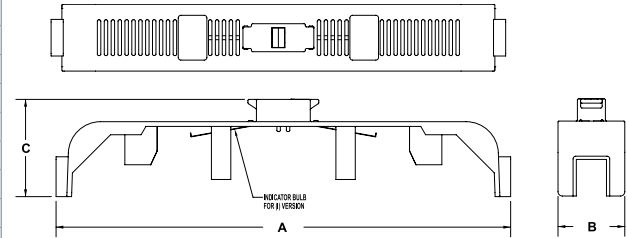

FUSES AND FUSE BLOCKS FOR USE WITH DFC

Fuse	Fuse Block	DFC	Fuse	Fuse Block	DFC
AG(0-30)	40xxxG	-7I, -7	A6K(35-60)R	606xxR	-5I, -5
AJT(1-30)	603xxJ	-1I, -1	A6K(70-100)R	610xxR	-8I, -8
AJT(1-30)	603xxSJ	10I, -10	A6Y(0-30)-2B	303xx	-7I, -7
AJT(35-60)	606xxJ	-6I, -6	A600(0-30)-2	303xx	-7I, -7
AJT(70-100)	610xxJ	-3I, -3	A60X(0-30)-1	603xx	-1I, -1
AJT(70-100)	6100xxSJ	-11I, -11	A70P(10-30)-1	203xx	-9I, -9
AJT(110-200)	620xxJ	-12I, -12	GFN(0-30)	303xx	-7I, -7
ATDR(0-30)	303xxR	-7I, -7	GGU(0-30)	303xx	-7I, -7
ATM(0-30)	303xx	-7I, -7	HSJ(15-30)	603xxSJ	-10I, -10
ATMR(0-30)	303xxR	-7I, -7	HSJ(70-100)	6100xxSJ	-11I, -11
AT0(0-30)	303xx	-7I, -7	HSJ(110-200)	620xxJ	-12I, -12
ATOR(0-30)	303xxR	-7I, -7	OT(0-30)	203xx	-9I, -9
A13X(1-30)-2	303xx	-7I, -7	OT(35-60)	206xx	-13I, -13
A2D(0-30)R	203xxR	-9I, -9	OT(65-100)	210xx	-4I, -4
A2D(35-60)R	206xxR	-13I, -13	OTM(0-30)	303xx	-7I, -7
A2D(65-100)R	210xxR	-4I, -4	OTS(0-30)	603xx	-2I, -2
A2K(0-30)R	203xxR	-9I, -9	OTS(35-60)	606xx	-5I, -5
A2K(35-60)R	206xxR	-13I, -13	OTS(65-100)	610xx	-8I, -8
A2K(70-100)R	210xxR	-4I, -4	RF(0-30)	203xx	-9I, -9
A2Y(0-30)	203xx	-9I, -9	RF(35-60)	206xx	-13I, -13
A2Y(35-60)	206xx	-13I, -13	RF(65-100)	210xx	-4I, -4
A2Y(70-100)	210xx	-4I, -4	RFS(0-30)	603xx	-2I, -2
A25X(1-30)-1	203xx	-9I, -9	RFS(35-60)	606xx	-5I, -5
A25Z(1-30)-2	303xx	-7I, -7	RFS(65-100)	610xx	-8I, -8
A4J(1-30)	603xxJ	-1I, -1	TR(0-30)R	203xx	-9I, -9
A4J(1-30)	603xxSJ	-10I, -10	TR(35-60)R	206xx	-13I, -13
A4J(35-60)	606xxJ	-6I, -6	TR(70-100)R	210xx	-4I, -4
A4J(70-100)	610xxJ	-3I, -3	TRM(0-30)	303xx	-7I, -7
A4J(70-100)	6100xxSJ	-11I, -11	TRS(0-30)R	603xxR	-2I, -2
A4J(110-200)	620xxJ	-12I, -12	TRS(35-60)R	606xxR	-5I, -5
A50P(10-30)	203xx	-9I, -9	TRS(65-100)R	610xxR	-8I, -8
A6D(0-30)R	603xxR	-2I, -2	TRS(35-60)RDC	606xxR	-5I, -5
A6D(35-60)R	606xxR	-5I, -5	TRS(70-100)RDC	610xxR	-8I, -8
A6D(70-100)R	610xxR	-8I, -8			
A6K(0-30)R	603xxR	-2I, -2			

Note: DFC Covers fit single pole blocks and each pole of multi-pole blocks.
Consult factory for data sheets of DFC trim instructions for safety switches.
WARNING: To avoid electrical shock, TURN POWER OFF before installing, removing or servicing.

FB

DFC3M/DFC3LP/DRM

Fuse Block Accessories

FUSE BLOCKS & HOLDERS



FB

DFC3M SAFETY PULLER PROTECTS PERSONNEL, COVERS LIVE PARTS

The DFC3M safety puller is intended to hold and safely enclose 1-1/2" x 13/32" midget or Class CC fuses for insertion or removal from fuse clips, making fuse installation easy and safe without the use of a standard fuse puller. The DFC3M is made of clear polycarbonate, so the fuse can be identified when installed in a 303 series fuse block.

DFC3LP SAFETY PULLER HOLDS FUSE, PROTECTS PERSONNEL, AND SAVES SPACE

The DFC3LP holds and safely encloses 1-1/2" x 13/32" midget or class CC fuse, similar to the DFC3M, but with a lower profile in height so it takes less room where space is restricted. The DFC3LP is made of clear polycarbonate so the fuse can be seen after installation in a fuse block such as the Mersen 303 series.

DRM ADAPTS 303 SERIES MIDGET AND CLASS CC FUSE BLOCKS TO DIN-RAIL

The DIN-rail adapter, DRM, provides quick mounting for all Mersen 303 series midget and class CC fuse blocks to all symmetrical 35mm DIN or asymmetrical 32mm "G" rail. A DRM adapter is attached to each pole with the screw provided. The DRM is molded of black polycarbonate and is mounted or dismounted from the rail simply by depressing the finger pull.

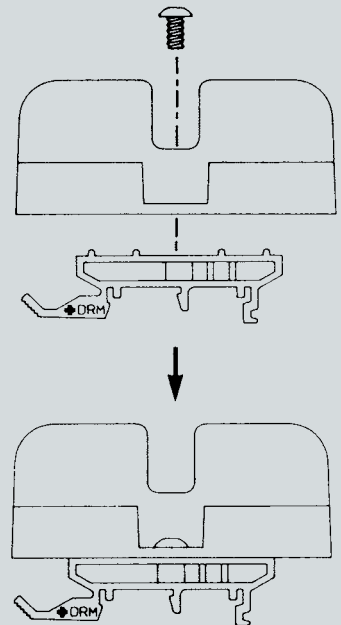

Fuse Clips

For Ferrule Fuses/PC Board Mount

FUSE BLOCKS & HOLDERS

30A & 60A FERRULE FUSE CLIPS



Cat. No.	For Fuse Rating/Size			Mounting Details	
	Volts	Amps (max)	Ferrule Dia.	Hole Size	Screw Size
C08915P	600	30	13/32"	.72 dia.	#8
C08919P	600	30	13/32"	.196 dia.	#10
C08916P	250	30	9/16"	.172 dia.	#8
C08917P	250	60	13/16"	.22 X .30"	#10
	600	30	13/16"	.22 X .30"	#10
C08918P	600	60	1-1/16"	.22 X .30"	#10

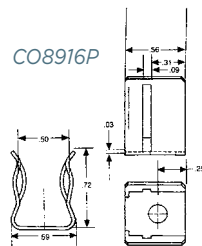
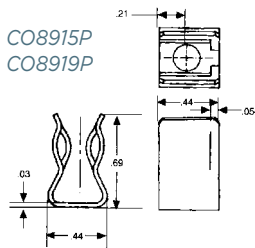

All clips are UL recognized: guide IZLT2, file E52283

All clips are tin-plated copper alloy, non-spring reinforced.

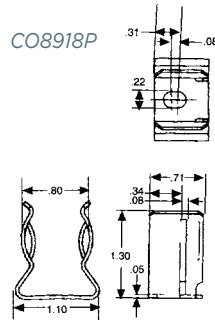
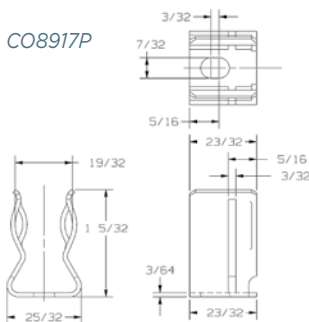

SDC5 PC BOARD CLIPS

- PC board mount fuse clip
- For 5mm diameter fuses
- Tin plated hard brass

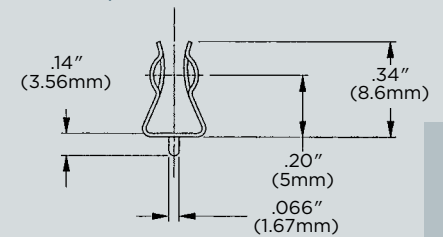

FB

SDC6 PC BOARD CLIPS

- PC board mount fuse clip
- For 1/4" diameter fuses
- Tin plated hard brass

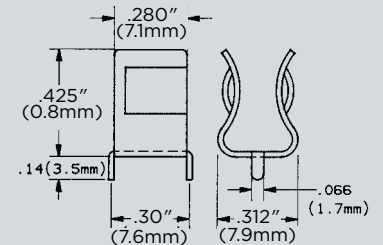

SDC7 PC BOARD CLIPS

- PC board mount fuse clip
- For 13/32" diameter fuses
- Tin plated hard brass

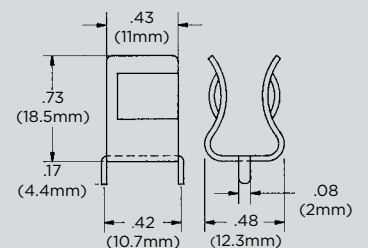



Your problem: You're facing the enormously complex wiring requirements of an automated manufacturing facility. Or the compatibility problems of a commercial complex retrofit. Or the need for seamless electrical service in a hospital annex that's anything but seamless. Where can you turn to solve your power distribution problems?

Our solution: Well beyond circuit protection solutions. Mersen offers you an arsenal of circuit management products. One of which is our line of polycarbonate 600V / 90 to 1520A Power Distribution Blocks. Safe and convenient, durable and easy to install, they're the simple way to split primary power circuits into secondary circuits — or provide fixed-junction tap-off points. Mersen's comprehensive line of PDBs includes open style and enclosed blocks in a wide range of configurations. Copper and aluminum blocks are available in either style with a full complement of accessories.

Want more information fast?

For more technical or application-specific information, please call our Power Distribution Block experts at 978-465-4853 or visit our website at ep.mersen.com.

Power Distribution Blocks

A POWERFUL WAY TO MANAGE YOUR POWER DISTRIBUTION CHALLENGES

- FSPDB Series Finger-Safe Power Distribution Blocks PD 2
- MPDB Series Open-Style Power Distribution Blocks PD 4
- MPDB62-MPDB63 (Mini) Open-Style PDBs. PD 6
- MPDB66-MPDB67 (Intermediate) Open-Style PDBs. PD 7
- MPDB68-MPDB69 (Large) Open-Style PDBs. PD 9
- MPDB Double-Wide Open-Style PDBs. PD 11
- Dimensions PD 12

FSPDB

Finger-Safe Power Distribution Blocks

POWER DISTRIBUTION BLOCKS

SAFETY EVOLVING



Mersen FSPDBs introduce a new level of safety and ease for installing power distribution blocks. An IP20 level of finger-safe protection is achieved using FSPDBs, eliminating the need for special covers or custom plexiglass sheets to protect your panels. FSPDBs (sizes 1 to 4) simply snap onto 35mm DIN rail to provide the quickest installation. Modular design also allows for multi pole applications by use of assembly pins. FSPDBs provide a safe, convenient way of splicing cables, splitting primary power into a variety of secondary circuits or providing a fixed junction tap-off point.

FEATURES/BENEFITS:

- **Finger-safe protection:** Fully insulated block ensures touch safe isolation of live parts. Recessed termination screws and wire openings provide IP20 grade protection and qualify as “finger-safe” per IEC 529.
- **Compact modularity:** Single or multiple pole configurations in the most compact footprint. Allows users to build smaller or higher density panels.
- **Snap on DIN-rail mounting:** Sizes 1 to 4 feature integral DIN rail adaptors allowing for quick and easy installations on 35mm DIN rail yielding lower installed costs.
- **Captive termination screws:** Unique channel design ensures captive metric wire termination screws. Screws can never be lost.
- **Available accessories:** For multi-pole panel mounting, simply snap in pins for rigid fit. Cap plugs provide the ability to maintain touch safety on unused openings. Circuit identification markers simply snap into blocks to ID circuits. End anchors provide rigid end stops. (Continued on next page.)

RATINGS:

- **Volts:** FSPDB1,2,3— 1500VAC/DC; FSPDB4,5— 600VAC/DC
- **Amps:** 175 to 840A
- **SCCR:** 600V or less, 100kA with proper fuse; Over 600V, 10kA

Contact Technical Services for instruction sheet.

APPROVALS:

- UL Recognized Component Guide XCFR2, File E73571
- CSA Certified: Class 6228, File 69363
- IEC-947-7-1, 529, 68-2-6, CE Marked



PD

FEATURES/BENEFITS (CONTINUED):

- **Multiple wire ratings:** Provide users more versatility by offering capability of using multiple conductors in #2 and 2/0 openings.
- **AC & DC ratings:** FSPDB1, 2, and 3 have been evaluated for use at 1500V (AC or DC) provided they are installed on DIN-rails only and with proper barriers and spacing between poles of opposite polarity.

CATALOG NUMBERS

Catalog Number		Ampere Rating (Based on NEC Table 310-16 for 75° C Cu wire only)	Line			Load		Openings Per Pole	Short Circuit Current Rating
Aluminum [Connector rated for 90° C Cu/AL wire]	Copper [Connector rated for 75° C Cu wire only]		Wire Range		Openings	Wire Range			
			AWG/	mm ²		AWG/ kcmil	mm ²		
FSPDB1A	FSPDB1C	175	2/0-#14	70-2.5	1	2/0-#14	70-2.5	1	100kA•
FSPDB2A	FSPDB2C	175	2/0-#14	70-2.5	1	#2-#14	35-2.5	4	100kA•
FSPDB3A	FSPDB3C	310	350-#6	185-16	1	#8-#14	8-2.5	8	100kA•
			2/0-#14	70-2.5					
FSPDB4A	FSPDB4C	335	400-#6	185-16	1	400-#6	185-16	1	100kA•
FSPDB5A	FSPDB5C	840	600-#4	300-25	2	600-#4	300-25	2	100kA•

*Contact Mersen Technical Services at technicalservices.nby@mersen.com for fuse type and maximum ampere required.

Multiple Wire Ratings (Same Size & Type Wires Only)					
2/0 Openings			#2 Openings		
(2) #4 AWG	(2) #8 AWG	(2) #12 AWG	(2) #6 AWG	(2-4) #10 AWG	(2-4) #14 AWG
(2) #6 AWG	(2) #10 AWG	(2) #14 AWG	(2) #8 AWG	(2-4) #12 AWG	

DIMENSIONS

Dimension	FSPDB1A FSPDB1C Figure 1		FSPDB2A FSPDB2C Figure 1		FSPDB3A FSPDB3C Figure 2		FSPDB4A FSPDB4C Figure 1		FSPDB5A FSPDB5C Figure 2	
	mm	in	mm	in	mm	in	mm	in	mm	in
A	25.4	1.00	28.4	1.12	46.9	1.85	39	1.54	72	2.84
B	43.3	1.70	57.8	2.28	64.3	2.53	108	4.25	91	3.58
C	49.5	1.95	56.0	2.21	64.3	2.53	80	3.15	80	3.15
D	45.1	1.78	51.6	2.03	59.8	2.36	75.5	2.97	-	-
E	39.4	1.55	39.4	1.55	51.5	2.03	50.1	1.97	50.1	1.97
F	72.6	2.86	87.7	3.45	100.8	3.97	145.5	5.73	145	5.71
G	59.6	2.35	74.6	2.94	82.4	3.24	120.6	4.75	127.5	5.02
H	5.3	0.21	5.1	0.20	6.5	0.26	7	0.28	3	0.12
I	-	-	-	-	31.5	1.24	-	-	52	2.04
J	5.3	0.21	6.4	0.25	6.5	0.26	6.5	0.26	6.5	0.26
K	10	0.40	11.7	0.46	8.9	0.35	16	0.63	8.5	0.34

ACCESSORIES

Catalog No.	Description
FSPIN1	Accessory pin to form multiple pole block
FSCIM1	Circuit identification marker for 2/0 & #2 max. conductors (80 per card)
FSCIM2	Circuit identification marker for 350, 400 & 600 kcmil max. conductors (56 per card)
FSCAP1	Cap plug for spare 2/0 openings
FSCAP2	Cap plug for spare 350 kcmil openings
FSCAP3	Cap plug for spare 600 kcmil opening
FSEA	Pair of end anchors

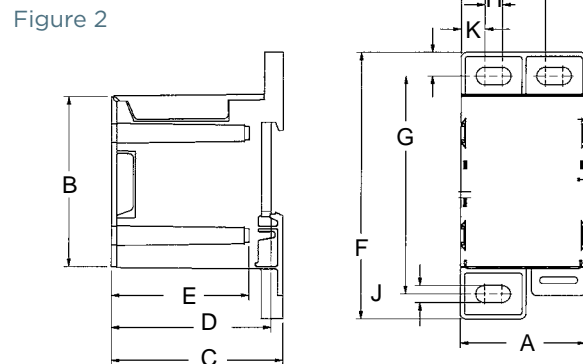
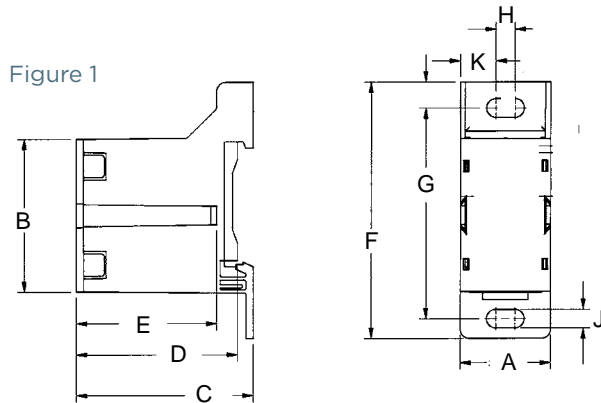

**P
D**

MPDB Series

Open-Style Power Distribution Blocks

POWER DISTRIBUTION BLOCKS

THE NEXT GENERATION POWER DISTRIBUTION BLOCK (PDB)



Mersen power distribution blocks provide a safe and easy method of splicing cables, splitting primary power into secondary circuits and fulfilling requirements for fixed junction tap-off points. Unless noted otherwise, all blocks are UL and CSA approved while meeting spacing requirements for feeder and branch circuits in conjunction with UL508A and the National Electrical Code®. PDB options include single or dual conductor primary inputs and up to 30 secondary outputs. Specialty blocks are available allowing for up to 7 primary inputs. The MPDB series is offered in three size categories: miniature (MPDB62 and MPDB63 series), intermediate (MPDB66 and MPDB67 series), and large (MPDB68 and MPDB69 series), in both aluminum and copper.

FEATURES/BENEFITS:

- **Adder Poles:** All sizes have optional adder poles for increased flexibility and ease-of-use. Adder poles can be stacked to form multi-pole units in the field without the use of tools. Adder poles allow for customization of primary and secondary wire combinations. End barriers are also available for sale, catalog numbers can be found in the catalog number selection tables for each size block.
- **Wire Connectors:** Standard aluminum and copper wire connectors are available. Aluminum connectors accept both AL or CU wire while copper connectors accept CU wire only. Connectors are all 1-piece tin-plated. Many part numbers are rated to accept DLO-type fine-strand wire, allowing users to connect flexible conductors. (Continued on next page.)

RATINGS:

- **Volts:** 1000VAC/DC
- **Amps:** 65 to 2260A based on NEC table 310.15(B)(16) 75°C ampacities
- **SCCR:** 100kA with properly sized fuse (See Mersen's PDB SCCR guide at ep.mersen.com or contact Mersen Technical Services)

APPROVALS:

- UL Listed to subject 1953, File E352417 unless noted otherwise
- CSA Certified Class 6228 01



P
D

FEATURES/BENEFITS (CONTINUED):

- **Insulators:** Insulators are virtually unbreakable, made of glass-filled polycarbonate. “See-through,” hinged safety covers are optional and provide a greater degree of safety and shock resistance where required. Hinged covers can be installed without tools.
- **Spacings:** 1 inch through air and 2 inches over surface between uninsulated live parts of opposite polarity meets requirements for feeder and branch circuit applications of UL508A.
- **Safety Covers:** Polycarbonate safety covers provide dead-front protection. One cover is needed for each pole. Each cover has a test probe hole in the center for circuit checking. Covers are optional accessories and catalog numbers can be found in the catalog selection tables for each size block.

ADDITIONAL SPECIFICATIONS:

- Wire Type:** Copper Blocks: 60/75°C Solid/Stranded CU; Aluminum Blocks: 60/75/90°C Solid/Stranded AL and CU
- Connector:** Copper Blocks: Highly conductive tin-plated copper; Aluminum Blocks: Highly conductive tin-plated aluminum
- Insulating Material:** Glass-filled polycarbonate with verified dielectric strength in excess of 2500V
- Flammability:** UL94-V0
- Mounting:** Direct panel mount
- Environmental:** RoHS compliant, Lead Free

PART SELECTION NOTES

MPDBs in each size category come in one, two, and three pole configurations (ending in -1, -2, and -3 accordingly). Users also have the ability to field install additional poles, end barriers, and safety covers.

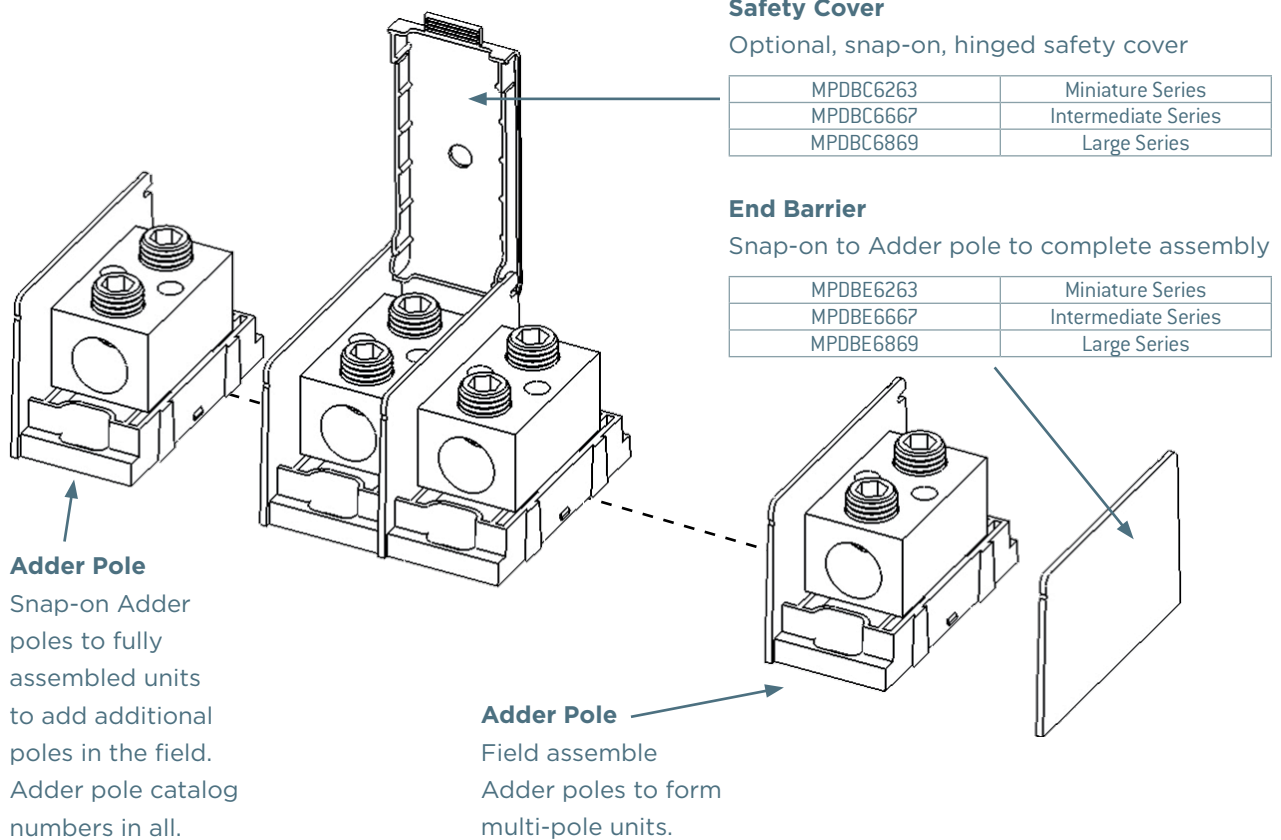

P
D

CATALOG NUMBERS, MINIATURE ALUMINUM MPDBs,
BOX-BOX CONFIGURATION

Line Side		Load Side		Catalog Numbers				Ampere Rating per Pole	
Wire Range	Openings per Pole	Wire Range	Openings per Pole	ADDER	1-P	2-P	3-P	Cu Wire	Al Wire
4-14	1	4-14	1	MPDB63100	MPDB63101	MPDB63102	MPDB63103	85	65
4-14	1	4-14	4	MPDB63160	MPDB63161	MPDB63162	MPDB63163	85	65
6-14 (DLO)		6-14 (DLO)						65 (DLO)	
2/0-14	1	2/0-14	1	MPDB63150	MPDB63151	MPDB63152	MPDB63153	175	135
1/0-14 (DLO)		1/0-14 (DLO)						125 (DLO)	
2/0-14	1	2-14	2	MPDB63190	MPDB63191	MPDB63192	MPDB63193	175	135
1/0-14 (DLO)		3-14 (DLO)						125 (DLO)	
2/0-14	1	4-14	4	MPDB63130	MPDB63131	MPDB63132	MPDB63133	175	135
1/0-14 (DLO)		6-14 (DLO)						125 (DLO)	

(DLO) Indicates Ampere Rating or Wire Range applicable to DLO class wire.

CATALOG NUMBERS, MINIATURE ALUMINUM MPDBs,
BOX-STUD CONFIGURATION

Line Side		Load Side		Catalog Numbers				Ampere Rating per Pole	
Wire Range	Openings per Pole	Stud Size	Studs per Pole	ADDER	1-P	2-P	3-P	Ratings (Cu)	Ratings (Al)
2/0-14	1	1/4" - 20 x 5/8"	1	MPDB63140	MPDB63141	MPDB63142	MPDB63143	175	135

CATALOG NUMBERS, MINIATURE COPPER MPDBs,
BOX-BOX CONFIGURATION

Line Side		Load Side		Catalog Numbers				Ampere Rating per Pole
Wire Range	Openings per Pole	Wire Range	Openings per Pole	ADDER	1-P	2-P	3-P	Rating (Cu)
4-14	1	4-14	1	MPDB62100	MPDB62101	MPDB62102	MPDB62103	85
4-14	1	4-14	4	MPDB62160	MPDB62161	MPDB62162	MPDB62163	85
2/0-14	1	2/0-14	1	MPDB62150	MPDB62151	MPDB62152	MPDB62153	175
2/0-14	1	2-14	2	MPDB62190	MPDB62191	MPDB62192	MPDB62193	175
2/0-14	1	4-14	4	MPDB62130	MPDB62131	MPDB62132	MPDB62133	175

(DLO) Indicates Ampere Rating or Wire Range applicable to DLO class wire.

CATALOG NUMBERS, MINIATURE COPPER MPDBs,
STUD-STUD CONFIGURATION

Line Side		Load Side		Catalog Numbers				Ampere Rating per Pole	
Stud Size	Studs per Pole	Stud Size	Studs per Pole	ADDER	1-P	2-P	3-P	Ratings (Cu)	Ratings (Al)
1/4"-20 X 5/8"	1	1/4"-20 X 5/8"	1	MPDB62200	MPDB62201	MPDB62202	MPDB62203	240	240

Hinged Safety Cover for MPDB62 and MPDB63 series: Catalog number MPDBC6263

End Barrier for MPDB62 and MPDB63 series: Catalog Number MPDBE6263

PD

CATALOG NUMBERS, INTERMEDIATE ALUMINUM MPDBs,
BOX-BOX CONFIGURATION

Line Side		Load Side		Catalog Numbers				Amp Rating per Pole	
Wire Range	Openings per Pole	Wire Range	Openings per Pole	ADDER	1-P	2-P	3-P	Cu Wire	Al Wire
2/0-14	1	2/0-14	1	MPDB67050	MPDB67051	MPDB67052	MPDB67053	175	135
2/0-14	1	2-14	4	MPDB67570	MPDB67571	MPDB67572	MPDB67573	175	135
1/0-14 (DLO)		4-14 (DLO)						150 (DLO)	
2/0-14	1	2-14	6	MPDB67560	MPDB67561	MPDB67562	MPDB67563	175	135
1/0-14 (DLO)		4-14 (DLO)						150 (DLO)	
2/0-14	1	2-14	8 ^M	MPDB67580	MPDB67581	MPDB67582	MPDB67583	175	135
1/0-14 (DLO)		4-14 (DLO)						150 (DLO)	
2/0-14	1	6-14	10 ^M	MPDB67590	MPDB67591	MPDB67592	MPDB67593	175	135
1/0-14 (DLO)		8-14 (DLO)						150 (DLO)	
2/0-14	1	10-14	12	MPDB67110	MPDB67111	MPDB67112	MPDB67113	175	135
1/0-14 (DLO)		12-14 (DLO)						150 (DLO)	
350-6	1	350-6	1	MPDB67000	MPDB67001	MPDB67002	MPDB67003	310	250
313-6 (DLO)		313-6 (DLO)						285 (DLO)	
350-6	1	2/0-14	2 ^M	MPDB67010	MPDB67011	MPDB67012	MPDB67013	310	250
313-6 (DLO)		1/0-14 (DLO)						2	
350-6	1	2-14	4 ^M	MPDB67670	MPDB67671	MPDB67672	MPDB67673	310	250
313-6 (DLO)		4-14 (DLO)						285 (DLO)	
350-6	1	2-14	6	MPDB67660	MPDB67661	MPDB67662	MPDB67663	310	250
313-6 (DLO)		4-14 (DLO)						285 (DLO)	
350-6	1	2-14	8	MPDB67630	MPDB67631	MPDB67632	MPDB67633	310	250
313-6 (DLO)		4-14 (DLO)						285 (DLO)	
350-6	1	6-14	10	MPDB67650	MPDB67651	MPDB67652	MPDB67653	310	250
350-6	1	10-14	15	MPDB67620	MPDB67621	MPDB67622	MPDB67623	310	250
500-4	1	500-4	1	MPDB67400	MPDB67401	MPDB67402	MPDB67403	380	310
500-4	1	350-6 & 2-14	1 & 3	MPDB67450	MPDB67451	MPDB67452	MPDB67453	380	310
500-4	1	4/0-10	2	MPDB67420	MPDB67421	MPDB67422	MPDB67423	380	310
500-4	1	2/0-14	4 ^M	MPDB67410	MPDB67411	MPDB67412	MPDB67413	350	310
373-4 (DLO)		1/0-14 (DLO)	4					320 (DLO)	
500-4	1	2/0-14	6 ^M	MPDB67460	MPDB67461	MPDB67462	MPDB67463	350	310
373-4 (DLO)		4-14 (DLO)	6					320 (DLO)	
500-4	1	2-14	8	MPDB67430	MPDB67431	MPDB67432	MPDB67433	380	310
500-4	1	6-14	10	MPDB67480	MPDB67481	MPDB67482	MPDB67483	380	310
500-4	1	10-14	18	MPDB67490	MPDB67491	MPDB67492	MPDB67493	380	310
2/0-14	2	2/0-14	2 ^M	MPDB67020	MPDB67021	MPDB67022	MPDB67023	350	270
1/0-14 (DLO)		1/0-14 (DLO)	2					300 (DLO)	
2/0-14	2	2-14	6	MPDB67510	MPDB67511	MPDB67512	MPDB67513	350	270
1/0-14 (DLO)		3-14 (DLO)						300 (DLO)	
2/0-14	2	2-14	8	MPDB67610	MPDB67611	MPDB67612	MPDB67613	350	270
2/0-14	2	6-14	10	MPDB67530	MPDB67531	MPDB67532	MPDB67533	350	270
2/0-14	2	10-14	15	MPDB67550	MPDB67551	MPDB67552	MPDB67553	350	270
4/0-6	2	4/0-6	2 ^M	MPDB67520	MPDB67521	MPDB67522	MPDB67523	460	360
3/0-6 (DLO)		3/0-6 (DLO)	2					400 (DLO)	
4/0-6	2	2-14	6 ^M	MPDB67540	MPDB67541	MPDB67542	MPDB67543	460	360
3/0-6 (DLO)		4-14 (DLO)	6					400 (DLO)	

* Indicates part numbers that are not UL listed (DLO) Indicates Ampere Rating or Wire Range applicable to Copper DLO class wire (M) Indicates connection UL approved for use with multiple conductors in the same opening. Quantities and sizes of wires are as follows:

#2-#14 Openings	(4) #14	(4) #12	(2) #10						
4/0-#6 Openings	(2) #2	(2) #3	(2) #4	(2) #6					
200-#4 Openings	(2) #4	(2) #3	(2) #2	(2) #1	(2) 1/0	(2) #2/0	(2) 3/0		

CATALOG NUMBERS, INTERMEDIATE ALUMINUM MPDBs,
BOX-STUD CONFIGURATION

Line Side		Load Side		Catalog Numbers				Amp Rating per Pole	
Wire Range	Inputs	Stud Size	Outputs	ADDER	1-P	2-P	3-P	Ratings (Cu)	Ratings (Al)
350-6	1	3/8"-16 X 1-1/16"	1	MPDB67250	MPDB67251	MPDB67252	MPDB67253	310	250
500-4	1	3/8"-16 X 1-1/16"	1	MPDB67220	MPDB67221	MPDB67222	MPDB67223	380	310

Hinged Safety Cover for MPDB66 and MPDB67 series: Catalog number MPDBC6667

End Barrier for MPDB66 and MPDB67 series: Catalog Number MPDBE6667

CATALOG NUMBERS, INTERMEDIATE COPPER MPDBs,
BOX-BOX CONFIGURATION

Line Side		Load Side		Catalog Numbers				Ampere Rating per Pole	
Wire Range	Openings per Pole	Wire Range	Openings per Pole	ADDER	1-P	2-P	3-P	Cu Wire	
2/0-14	1	2/0-14	1	MPDB66050	MPDB66051	MPDB66052	MPDB66053	175	
2/0-14	1	2-14	4	MPDB66570	MPDB66571	MPDB66572	MPDB66573	175	
2/0-14	1	2-14	6	MPDB66560	MPDB66561	MPDB66562	MPDB66563	175	
2/0-14	1	2-14	8	MPDB66580	MPDB66581	MPDB66582	MPDB66583	175	
2/0-14	1	6-14	10	MPDB66590	MPDB66591	MPDB66592	MPDB66593	175	
2/0-14	1	10-14	12	MPDB66110	MPDB66111	MPDB66112	MPDB66113	175	
350-6	1	350-6	1	MPDB66000	MPDB66001	MPDB66002	MPDB66003	310	
350-6	1	2/0-14	2	MPDB66010	MPDB66011	MPDB66012	MPDB66013	310	
350-6	1	2-14	4	MPDB66670	MPDB66671	MPDB66672	MPDB66673	310	
350-6	1	2-14	6	MPDB66660	MPDB66661	MPDB66662	MPDB66663	310	
350-6	1	2-14	8	MPDB66630	MPDB66631	MPDB66632	MPDB66633	310	
350-6	1	6-14	10	MPDB66650	MPDB66651	MPDB66652	MPDB66653	310	
350-6	1	10-14	15	MPDB66620	MPDB66621	MPDB66622	MPDB66623	310	
500-4	1	500-4	1	MPDB66400	MPDB66401	MPDB66402	MPDB66403	380	
500-4	1	350-6 & 2-14	1 & 3	MPDB66450	MPDB66451	MPDB66452	MPDB66453	380	
500-4	1	2/0-14	4	MPDB66410	MPDB66411	MPDB66412	MPDB66413	380	
500-4	1	2-14	6	MPDB66460	MPDB66461	MPDB66462	MPDB66463	380	
500-4	1	10-14	18	MPDB66490	MPDB66491	MPDB66492	MPDB66493	380	
2/0-14	2	2/0-14	2	MPDB66020	MPDB66021	MPDB66022	MPDB66023	350	
2/0-14	2	2-14	6	MPDB66510	MPDB66511	MPDB66512	MPDB66513	350	
2/0-14	2	2-14	8	MPDB66610	MPDB66611	MPDB66612	MPDB66613	350	
2/0-14	2	6-14	10	MPDB66530	MPDB66531	MPDB66532	MPDB66533	350	
2/0-14	2	10-14	15	MPDB66550	MPDB66551	MPDB66552	MPDB66553	350	
4/0-6	2	4/0-10	2	MPDB66520	MPDB66521	MPDB66522	MPDB66523	460	
4/0-6	2	2-14	6	MPDB66540	MPDB66541	MPDB66542	MPDB66543	460	

(DLO) Indicates Ampere Rating or Wire Range applicable to DLO class wire

CATALOG NUMBERS, INTERMEDIATE COPPER MPDBs,
STUD-STUD CONFIGURATION

Line Side		Load Side		Catalog Numbers				Ampere Rating per Pole	
Stud Range	Studs per Pole	Stud Size	Studs per Pole	ADDER	1-P	2-P	3-P	Ratings [Cu]	Ratings [Al]
1/4"-20 X 1-5/16"	1	1/4"-20 X 1-5/16"	1	MPDB66270	MPDB66271	MPDB66272	MPDB66273	155	155
1/4"-20 X 1-5/16"	1	3/8"-16 X 1-1/8"	1	MPDB66200	MPDB66201	MPDB66202	MPDB66203	155	155
3/8"-16 X 1-1/8"	1	1/4"-20 X 1-5/16"	2	MPDB66230	MPDB66231	MPDB66232	MPDB66233	400	400
3/8"-16 X 1-1/8"	1	3/8"-16 X 1-1/8"	1	MPDB66260	MPDB66261	MPDB66262	MPDB66263	400	400

Hinged Safety Cover for MPDB66 and MPDB67 series: Catalog number MPDBC6667
End Barrier for MPDB66 and MPDB67 series: Catalog Number MPDBE6667

PD

CATALOG NUMBERS, LARGE ALUMINUM MPDBs,
BOX-BOX CONFIGURATION

Line Side		Load Side		Catalog Numbers				Ampere Rating per Pole	
Wire Range	Openings per Pole	Wire Range	Openings per Pole	ADDER	Number of Poles			Ratings (Cu)	Ratings (Al)
					1-P	2-P	3-P		
350-6	1	2/0-14	6	MPDB69170	MPDB69171	MPDB69172	MPDB69173	310	250
350-6	1	4-14	12	MPDB69150	MPDB69151	MPDB69152	MPDB69153	310	250
500-4	1	500-4	1	MPDB69050	MPDB69051	MPDB69052	MPDB69053	380	310
500-4	1	350-6	2	MPDB69060	MPDB69061	MPDB69062	MPDB69063	380	310
500-4	1	4/0-6	4	MPDB69510*	MPDB69511*	MPDB69512*	MPDB69513*	380	310
500-4	1	2/0-14	6	MPDB69070	MPDB69071	MPDB69072	MPDB69073	380	310
500-4	1	4-14	12	MPDB69080	MPDB69081	MPDB69082	MPDB69083	380	310
600-2	1	600-2	1	MPDB69640	MPDB69641	MPDB69642	MPDB69643	420	340
1000-250	1	1000-250	1	MPDB69000	MPDB69001	MPDB69002	MPDB69003	545	445
1000-250	1	500-4	2	MPDB69010	MPDB69011	MPDB69012	MPDB69013	545	445
1000-250	1	350-6	2	MPDB69020	MPDB69021	MPDB69022	MPDB69023	545	445
1000-250	1	2/0-14	6	MPDB69030	MPDB69031	MPDB69032	MPDB69033	545	445
1000-250	1	4-14	12	MPDB69040	MPDB69041	MPDB69042	MPDB69043	545	445
4-14	2	4-14	12	MPDB69180	MPDB69181	MPDB69182	MPDB69183	170	130
2/0-14	2	4-14	12	MPDB69160	MPDB69161	MPDB69162	MPDB69163	350	270
2/0-14	2	10-14	20	MPDB69600	MPDB69601	MPDB69602	MPDB69603	350	270
350-6	2	350-6	2	MPDB69120	MPDB69121	MPDB69122	MPDB69123	620	500
313-6 (DLO)		313-6 (DLO)						570 (DLO)	
350-6	2	2/0-14	6	MPDB69130	MPDB69131	MPDB69132	MPDB69133	620	500
350-6		4-14						12 ^M	
313-6 (DLO)	2	6-14 (DLO)	12	MPDB69140	MPDB69141	MPDB69142	MPDB69143	570 (DLO)	500
500-4		500-4						2 ^M	
373-4 (DLO)	2	373-4 (DLO)	2	MPDB69090	MPDB69091	MPDB69092	MPDB69093	640 (DLO)	620
500-4		4/0-6						4	
373-4 (DLO)	2	3/0-6 (DLO)	4	MPDB69310	MPDB69311	MPDB69312	MPDB69313	640 (DLO)	620
500-4		2/0-14						6	
500-4	2	2/0-14	8	MPDB69350*	MPDB69351*	MPDB69352*	MPDB69353*	760	620
500-4		4-14						12	
373-4 (DLO)	2	6-14 (DLO)	12	MPDB69110	MPDB69111	MPDB69112	MPDB69113	640 (DLO)	620
600-2		600-2						2	
600-2	2	4-14 & 3/0-10	4 & 4	MPDB69650	MPDB69651	MPDB69652	MPDB69653	840	680
600-2	2	4-14 & 3/0-10	4 & 4	MPDB69540	MPDB69541	MPDB69542	MPDB69543	840	680

* Indicates part numbers that are not UL listed

(DLO) Indicates Ampere Rating or Wire Range applicable to Copper DLO class wire

(M) Indicates connection UL approved for use with multiple conductors in the same opening. Quantities and sizes of wires are as follows:

#2-#14 Openings	(4) #14	(4) #12	(2) #10						
4/0-#6 Openings	(2) #2	(2) #3	(2) #4	(2) #6					
200-#4 Openings	(2) #4	(2) #3	(2) #2	(2) #1	(2) 1/0	(2) #2/0	(2) 3/0		

CATALOG NUMBERS, LARGE ALUMINUM MPDBs,
BOX-STUD CONFIGURATION

Line Side		Load Side		Catalog Numbers				Ampere Rating per Pole	
Wire Range	Openings per Pole	Stud Size	Studs per Pole	ADDER	1-P	2-P	3-P	Ratings (Cu)	Ratings (Al)
500-4	1	3/8"-16 X 1	1	MPDB69210	MPDB69211	MPDB69212	MPDB69213	380	310
500-4	1	3/8"-16 X 1"	2	MPDB69270	MPDB69271	MPDB69272	MPDB69273	380	310
1000-250	1	3/8"-16 X 1"	1	MPDB69280	MPDB69281	MPDB69282	MPDB69283	545	445
500-4	2	3/8"-16 X 1"	2	MPDB69230	MPDB69231	MPDB69232	MPDB69233	760	620

Hinged Safety Cover for MPDB68 and MPDB69 series: Catalog number MPDBC6869

End Barrier for MPDB68 and MPDB69 series: Catalog Number MPDBE6869



CATALOG NUMBERS, LARGE COPPER MPDBs,
BOX-BOX CONFIGURATION

Line Side		Load Side		Catalog Numbers				Ampere Rating per Pole	
Wire Range	Openings per Pole	Wire Range	Openings per Pole	ADDER	1-P	2-P	3-P	Cu Wire	
350-6	1	4-14	12	MPDB68150	MPDB68151	MPDB68152	MPDB68153	310	
500-4	1	350-6	2	MPDB68060	MPDB68061	MPDB68062	MPDB68063	380	
2/0-14	2	4-14	12	MPDB68160	MPDB68161	MPDB68162	MPDB68163	350	
350-6	2	350-6	2	MPDB68120	MPDB68121	MPDB68122	MPDB68123	620	
350-6	2	4/0-10	4	MPDB68320*	MPDB68321*	MPDB68322*	MPDB68323*	620	
350-6	2	2/0-14	6	MPDB68130	MPDB68131	MPDB68132	MPDB68133	620	
350-6	2	4-14	12	MPDB68140	MPDB68141	MPDB68142	MPDB68143	620	
500-4	2	500-4	2	MPDB68090	MPDB68091	MPDB68092	MPDB68093	760	
500-4	2	4/0-10	4	MPDB68310	MPDB68311	MPDB68312	MPDB68313	760	
500-4	2	2/0-14	6	MPDB68100	MPDB68101	MPDB68102	MPDB68103	760	
500-4	2	4-14	12	MPDB68110	MPDB68111	MPDB68112	MPDB68113	760	

* Indicates part numbers that are not UL listed

CATALOG NUMBERS, LARGE COPPER MPDBs,
STUD-BOX CONFIGURATION

Line Side		Load Side		Catalog Numbers				Ampere Rating per Pole	
Stud Size	Stud per Pole	Wire Range	Openings per Pole	ADDER	1-P	2-P	3-P	Ratings [Cu]	Ratings [Al]
1/2"-13 X 1"	1	4-14	12	MPDB68290	MPDB68291	MPDB68292	MPDB68293	1000	1000

CATALOG NUMBERS, LARGE COPPER MPDBs,
STUD-STUD CONFIGURATION

Line Side		Load Side		Catalog Numbers				Ampere Rating per Pole	
Stud Size	Stud per Pole	Wire Range	Stud per Pole	ADDER	1-P	2-P	3-P	Ratings [Cu]	Ratings [Al]
1/2"-13 X 1-3/8"	1	1/2"-13 X 1-3/8"	12	MPDB68220*	MPDB68221*	MPDB68222*	MPDB68223*	400	400

Hinged Safety Cover for MPDB68 and MPDB69 series: Catalog number MPDBC6869

End Barrier for MPDB68 and MPDB69 series: Catalog Number MPDBE6869

The MPDB double-wide series are designed for custom applications where large ampacities are required. Double-wide blocks are not UL or CSA certified unless otherwise noted. All double-wide blocks are Mersen self-certified and approved.

**DOUBLE WIDE ALUMINUM CATALOG NUMBERS,
BOX-BOX CONFIGURATION**

Line Side		Load Side		Catalog Numbers 1-P	Ampere Rating per Pole	
Wire Range	Openings per Pole	Wire Range	Openings per Pole		Cu Wire	Al Wire
1000-250	2	500-4	4	MPDB69561	1090	890
500-4	3	2/0-14	8	MPDB900061	1140	930
600-2	3	600-2	3	MPDB69331	1260	1020
500-4	4	500-4	4	MPDB900071	1520	1240
500-4	4	2/0-12	6	MPDB900121	1520	1240
500-4	4	6-14 & 2/0-14	22 & 4	MPDB69521	1520	1240
500-4	4	4-14	30	MPDB69191	1520	1240
600-2	4	600-2	4	MPDB69341	1680	1360

**DOUBLE WIDE COPPER CATALOG NUMBERS,
BOX-BOX CONFIGURATION**

Line Side		Load Side		Catalog Numbers 1-P	Ampere Rating per Pole	
Wire Range	Openings per Pole	Wire Range	Openings per Pole		Cu Wire	Al Wire
500-4	3	4/0-10	6	MPDB800011	1140	
500-4	4	500-4	4	MPDB800031	1520	
500-4	4	2/0-12	6	MPDB800121	1520	
500-4	7	500-4	7	MPDB800061 ^T	2660	

T Indicates that this block is triple-wide

**DOUBLE WIDE COPPER CATALOG NUMBERS,
BOX-STUD CONFIGURATION**

Line Side		Load Side		Catalog Numbers 1-P	Ampere Rating per Pole	
Wire Range	Openings per Pole	Stud Size	Studs per Pole		Ratings (Cu)	
500-4	4	3/8"-16 X 1"	4	MPDB900091	1520	

Hinged Safety Cover for Double-Wide MPDB series: Catalog number MPDBC692W



DIMENSIONS

Miniature (MPDB63133 shown for reference)

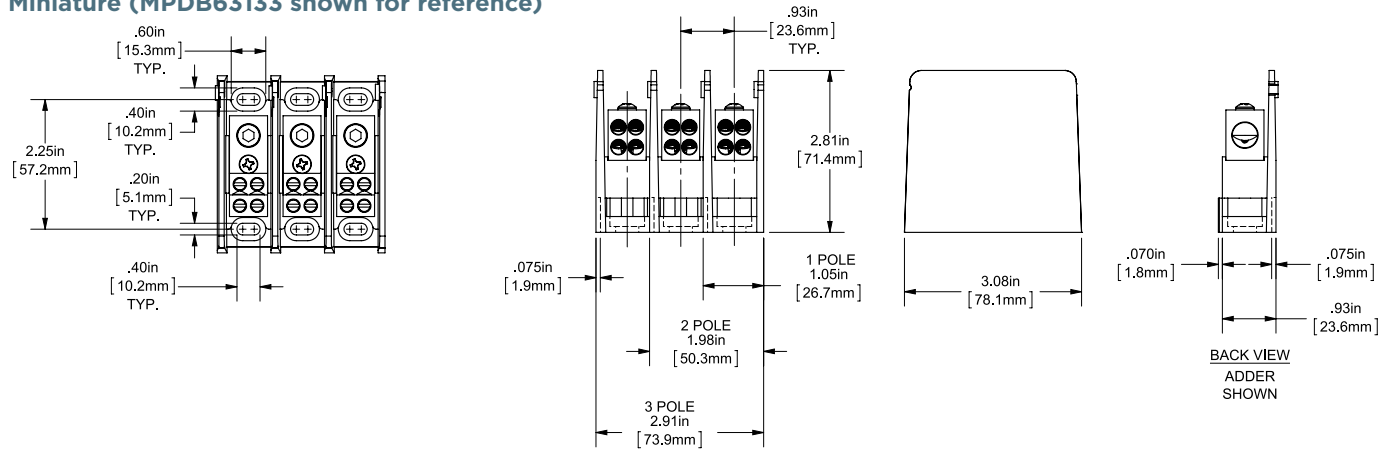

Intermediate (MPDB67563 shown for reference)

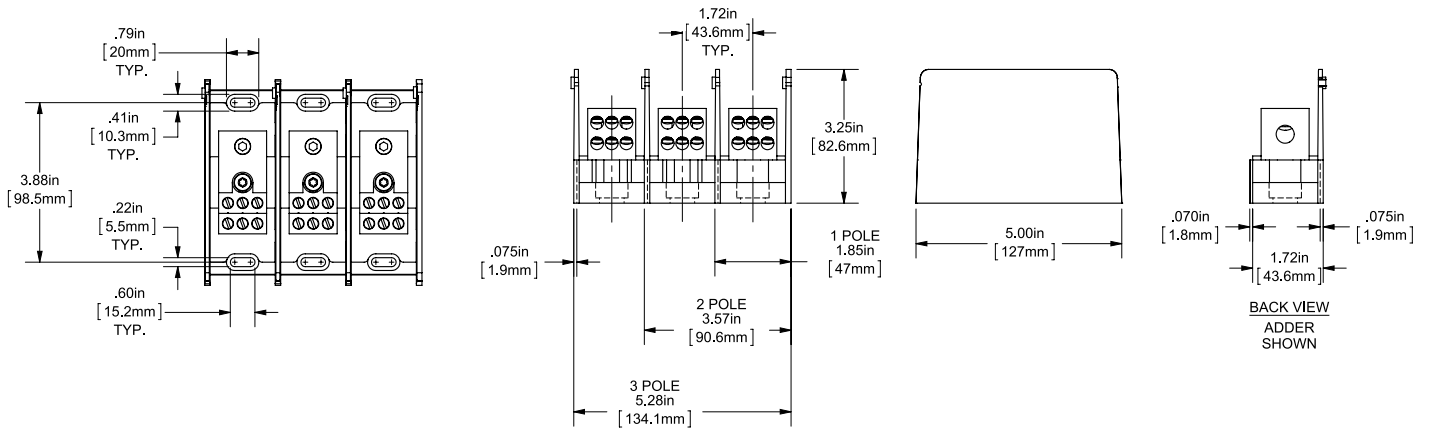

Large (MPDB69123 shown for reference)

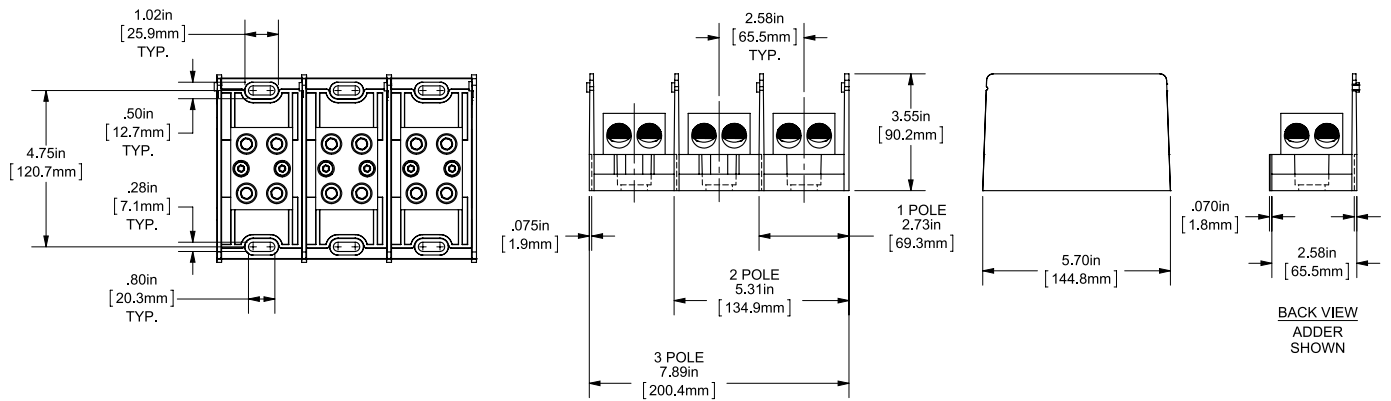

PD

DIMENSIONS (CONTINUED)

Double-Wide (MPDB69331 shown for reference)

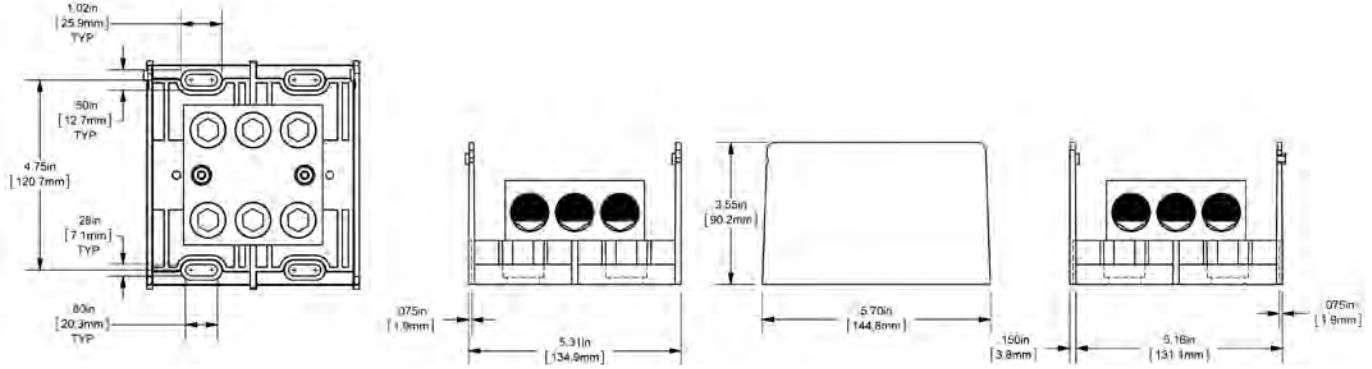

Triple-Wide (MPDB800061 shown for reference)

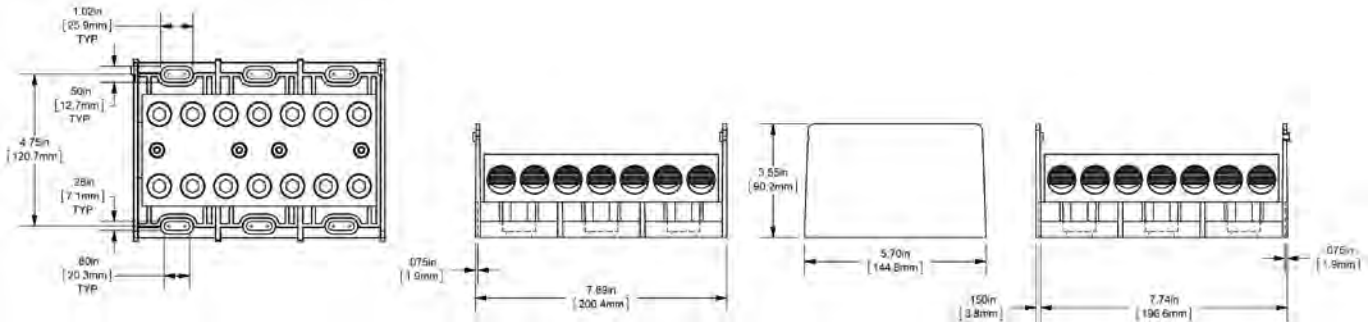

PD



Your problem: You need a range of disconnect switches for your industrial control requirements ranging from “Service Entrance Rated” to motor isolation. You need DIN-rail and direct mountable disconnect switches that conform to “finger-safe” standards. You need a flexible range of handles, shafts, and accessories to select from.

Our solution: Mersen offers an extensive line of compact UL 98 fusible and non-fusible disconnect switches ranging from 30 to 1200A. We also offer a full range of compact UL 508 disconnect switches ranging from 16 to 80A. In addition, you can find handle, shaft and accessory options that you require for all of your applications.

Want more information fast? For more technical or application-specific information, please call our Disconnect Switch experts at 978-465-4853 or visit our website at ep.mersen.com.

Low Voltage Disconnect Switches

THE SAFEST WAY
TO SWITCH POWER
ON AND OFF IN YOUR
INDUSTRIAL CONTROL
PANELS

- UL 508 Non-Fusible Disconnect Switches. DS 2
- UL 98 Non-Fusible Disconnect Switches. DS 5
- UL 98 Fusible Disconnect Switches. DS 10
- PV-Rated UL and IEC Disconnect Switches. DS 15
- Enclosed Disconnect Switches. DS 19

DS

UL 508 Non-Fusible

Disconnect Switches

DISCONNECT SWITCHES

M163 – M803



The M-series Load Break Switch is the most compact industrial-grade switch on the market. Capable of making or breaking loads up to 600V (UL), it is suitable as a motor disconnect. Extremely compact and robust, these switches have a variety of mounting options including DIN-rail, base, or door-mounting. A wide assortment of handles, shafts and accessories is available to accommodate any installation requirement.

APPLICATIONS:

- Line-of-sight disconnect
- Electrical isolation
- Branch-circuit switch
- Motor disconnect

RATINGS (UL):

- **Volts:** 600VAC
- **Amps:** 20, 30, 40, 63, and 80A. Suitable as motor disconnect up to 40hp.

FEATURES/ BENEFITS:

- Compact
- Robust
- DIN-rail, base, or door mounting
- Choice of handles and shafts
- Padlockable
- Side-mount auxiliary contacts and additional poles
- Double-break, silver-plated, contacts

APPROVALS:















- UL 508 listed E196672
- IEC 60947-3



Catalog number designation

M Switch	80 Ampacity	3 Number of Poles	— Special Configurations
M = Mersen AC Switch	16-80		DM: Door Mounting

DS

UL 508 Disconnect Switches—Front Operated						
						
M163	M163DM	M633	M633DM			
Switch Body	Ampere Rating	20	30	40	63	80
	Base Part #	M163	M253	M403	M633	M803
	Door-Mounted Version	M163DM	M253DM	M403DM	M633DM	M803DM
Handles and Shafts	Direct Front Operation Locking Handle					
		HD40	HD40	HD40	HD125	HD125
						
External Front Operation						
	Selector Style NEMA Type 1, 3R, 12	HSBX, HSRX				
	Shaft—SAxxx (xxx = length in mm)	SA85, SA105, SA120, SA130, SA180, SA250				
	Door mounted version (no shaft required)	HSBPDM, HSRPDM		HSBWDM, HSRWDM		
	Pistol Style NEMA Type 1, 3R, 12	HB45, HR45, HB65, HR65, HB80, HR80				
	NEMA Type 4, 4X	HB45X, HR45X, HB65X, HR65X, HB80, HB80X				
	NEMA 4X Stainless Steel	HM65X				
	Shaft— SAxxx (xxx = length in mm)	SPA130, SPA210, SPA290, SPA360, SPA430				
	B=Black, R=Black					
Accessories	Fourth Poles					
	Limited to one additional pole per switch	4P40	4P40	4P40	4P80	4P80
	Door mounted switch 4th poles are left-side mounted	4P40DM	4P40DM	4P40DM	4P80DM	4P80DM
						
						
4P40	4P80					
Neutral Poles						
	Limited to one additional pole per switch	NP40	NP40	NP40	NP80	NP80
	Door mounted switch neutral poles	NP40DM	NP40DM	NP40DM	NP80DM	NP80DM
Terminal Shrouds						
	3-pole	TS40-3	TS40-3	TS40-3	TS63-3	TS63-3
	4-pole (Add this to the 3-pole shroud)	TS40-1	TS40-1	TS40-1	TS63-1	TS63-1
Auxiliary Contacts*						
	NC Right side mounting	OA1G01	OA1G01	OA1G01	OA1G01	OA1G01
	NO left side mounting	OA1G10	OA1G10	OA1G10	OA1G10	OA1G10
	NO+NC (Mounting on either side)	OA2G11	OA2G11	OA2G11	OA2G11	OA2G11
						
						
						
OA1G10	OA1G01					
*Rated 2A max continuous @690VAC						

TECHNICAL DATA ACCORDING TO UL/cULus													
Part Number	pf= 0.7...0.8	-40° to 40 °C	A	M163		M253		M403		M633		M803	
General Purpose Amp Rating				20	30	40	60	80					
Maximum Operating Voltage			V	600	600	600	600	600	600	600	600	600	600
Max. horsepower rating / motor FLA current	pf= 0.4...0.5 Three phase	240 V	HP/A	5/15.2	7.5/22.0	10/28.0	15/42.0	20/54.0					
		480 V	HP/A	10/14.0	15/21.0	20/27.0	30/40.0	40/52.0					
		600 V	HP/A	11-Oct	20/22.0	25/27.0	30/32.0	40/41.0					
	Single phase	120 V	HP/A	1/16.0	1.5/20.0	2/24.0	2/24.0	2/24.0					
240 V		HP/A	2/13.2	3/18.7	5/30.8	7.5/40.0	10/57.5						
Short circuit rating with fuse	Maximum fuse size		A	30	60 ²⁾	30	60 ²⁾	30	60 ²⁾	100	150	100	150
	Fuse type	CC	kA	10		10		10					
	Fuse type	J	kA	10	10	10	10	10	10	100		100	
	Fuse type	T	kA	10	10	10	10	10	10	100		100	
	Fuse type	RK1	kA	10		10		10		10	5	10	5
	Fuse type	RK5	kA	5	5	5	5	5	5		5		5
	Fuse type	L	kA										
Fuse type	H	kA											
Endurances													
Min. electrical endurance, pf. 0.75...0.8			oper. cycles	6 000	6 000	6 000	6 000	6 000	6 000	6 000	6 000	6 000	6 000
Mechanical endurance			operations	20 000	20 000	20 000	20 000	20 000	20 000	20 000	20 000	20 000	20 000
Terminal lug kits				Integral	Integral	Integral	Integral	Integral	Integral	Integral	Integral	Integral	Integral
Wire range			AWG	18-8	18-8	18-8	14-4	14-4					
Torque		Wire tightening	lb. in	?	?	?	18	18					
		Lug mounting											
TECHNICAL DATA ACCORDING TO IEC 60947-3													
Rated insulation voltage and rated operational voltage AC20/DC20		Pollution degree 3	V	750	750	750	750	750	750	750	750	750	750
Dielectric strength		50 Hz 1min.	kV	6	6	6	6	6	6	6	6	6	6
Rated impulse withstand voltage			kV	8	8	8	8	8	8	8	8	8	8
Rated operational current, AC-22A		up to 415 V	A	16	25	40	63	80					
		440...500 V	A	16	25	40	63	80					
		690 V	A	16	25	40	63	80					
Rated operational current, AC-23A		up to 415 V	A	16	20	23	45	75					
		440 V	A	16	20	23	45	65					
		500 V	A	16	20	23	45	58					
		690 V	A	10	11	12	20	20					
Rated conditional short-circuit current I_p (r.m.s.) and corresponding max. allowed cut-off current i_c . The cut-off current i_c refers to values listed by fuse manufacturers	I_p (r.m.s.)	50 kA	kA	6.5	6.5	6.5	13	13					
	Max. fuse size gG/aM	415 V	A	40/32	40/32	40/32	100/80	100/80					
	I_p (r.m.s.)	10 kA	kA										
	Max. fuse size gG/aM	690 V	A										
[single phase test acc. to IEC60269]	I_p (r.m.s.)	50 kA	kA	4	4	4	11	11					
	Max. fuse size gG/aM	690 V	A	25/16	25/16	25/16	80/63	80/63					
	at prospective SC-current	80 kA	kA										
	Max. fuse size gG/aM	690 V	A										
Rated short-time withstand current	r.m.s. -value I_{cw}	690 V, 1 s	kA	0.5	0.5	0.5	1	1.5					
Rated short circuit making capacity	Peak value I_{cm}	690 V/500 V	A	0.705	0.705	0.705	1.4	2.1					
Power loss / pole	At rated operational current		W	0.3	0.6	1.6	2.8	4.5					
Mechanical endurance	Divide by two for operation cycles		Oper.	20 000	20 000	20 000	20 000	20 000					
Weight without accessories		3-pole	kg	0.11	0.11	0.11	0.27	0.27					
		4-pole	kg	0.15	0.15	0.15	0.35	0.35					

1) UL Listed switches are also CSA Approved. 2) Fuse size 70A for RK5.

DS

UL 98 Non-Fusible

Disconnect Switches

DISCONNECT SWITCHES



Mersen's non-fusible disconnect switches are listed to UL 98 and bear the CE mark as conformance to IEC 60947-3. They are "service entrance" devices that are capable of fully rated load-break and load-make. All switches over 100A have windows to provide visual indication of the contact status. Engineered to have the smallest footprint, these switches also employ a modular design that enables the handle to be placed amongst the poles or at the ends.

A wide range of ergonomic handles and accessories is available to accommodate multiple applications.

CONFIGURATIONS:



Gearbox on the side



Gearbox in the middle

Catalog number designation						
M Switch	200 Ampacity	U Type	3 Number of Poles/Left of handle	0 Number of Poles/Right of handle	— Revision	— Special Configuration
M = Mersen AC Switch	16-1200	U = non-fused UL 98	1-3	Blank = < 200A non-fused, 0, 2, 3	Blank = 0	F = Flange-mount Actuation DM = Door mounted

*Not all configurations are available.

RATINGS (UL):

- **Volts:** 600VAC
- **Amps:** 30A, 60A, 100A, 200A, 400A, 600A, 800A, 1200A
- **Short-Circuit Current Rating (SCCR):** Up to 200kA with fuses. Suitable as motor disconnect.

FEATURES/ BENEFITS:

- Service entrance rated
- Front operation
- Most compact size
- Internally mounted auxiliary contacts
- Flange mounting accessories
- Flexible mounting
- Adjustable shaft depth

APPROVALS:

- All UL switches meet the requirements of UL and CSA
- UL listed guide WHTY, File E191605 for UL 98 (ratings from 30 A to 1200 A)
- IEC 60947-3







*Not all configurations are available

DS

UL 98 DISCONNECT SWITCHES					
					
M100U3		M200U30 with HD250 Direct Handle		M200U30	
Switch Body	Ampere Rating	30	60	100	200
	Base Part #	M30U3	M60U3	M100U3	M200U
	3-pole configurations				12, 30
	For Flange-mount Actuation	M30U3F	M60U3F	M100U3F	
	For Door-mounting	M30U3DM	M60U3DM	M100U3DM	
Handles and Shafts	Direct Front Operation Locking Handle				
		HD125	HD125	HD125	HD250
	External Front Operation				
	Selector Style	HSBX, HSRX			N/A
	Shaft—SAxxx (xxx = length in mm)	SA85, SA105, SA120, SA130, SA180, SA250			N/A
	Door mounted version [no shaft required]	HSBWDM, HSRWDM			N/A
	Pistol Style NEMA Type 1, 3R, 12	HB45, HR45, HB65, HR65, HB80, HR80			
	NEMA Type 4, 4X	HB45X, HR45X, HB65X, HR65X, HB80X, HR80X			
	NEMA 4X Stainless Steel	HM65X			
	Shaft—SAxxx (xxx = length in mm)	SPA130, SPA210, SPA290, SPA360, SPA430			
	Alignment Ring	See next page			
	B=Black, R=Red				
Accessories	Fourth Poles				
	Base-mounted switch Fourth Poles	4P60	4P60	4P125	4P250
	Door-mounted switch Fourth Poles	4P60DM	4P60DM	4P125DM	
	Neutral Poles				
	Base-mounted switch Neutral Poles	NP60	NP60	NP125	
	Door-mounted switch Neutral Poles	NP125DM	NP125DM	NP125DM	
	Terminal Shrouds				
	3-pole	TS125-3	TS125-3	TS125-3	TS250-13
	4-pole	TS125-1	TS125-1	TS125-1	TS250-14
	Shrouds with "-3" suffix are single shrouds that cover all three terminals. Shrouds with "-13" or "-14" are single pole shrouds with 3 or 4 per				
	Auxiliary Contacts*				
	Normally Closed	OA1G01	OA1G01	OA1G01	OA3G01
	Normally Open	OA1G10	OA1G10	OA1G10	OA1G10
	N0+NC	OA2G11	OA2G11	OA2G11	
	Module for 8 aux. contacts	N/A	N/A	N/A	OEA28
	*Rated 2A max continuous @690VAC				
	Flange Operation				
	Flange bracket assembly	Incl with M30U3F**	Incl with M60U3F**	Incl with M100U3F**	FOM4
	Rod Flange handle NEMA 12	FHR12	FHR12	FHR12	NA
	Rod Flange handle NEMA 4X	FHR4X	FHR4X	FHR4X	NA
	Rod, 16 inch	RODNF16	RODNF16	RODNF16	NA
	Rod, 24 inch	RODNF24	RODNF24	RODNF24	NA
	Cable Flange Handle, NEMA 12	NA	NA	NA	FHC12
	Cable Flange Handle, NEMA 4X	NA	NA	NA	FHC4X
	Cable for FHC handles	NA	NA	NA	CABLE36*

Other cable lengths available: 48", 60", 72", 84", 96", 108". For example, CABLE108. **These switches have not been tested to conform to UL standards

UL LISTED FRONT OPERATED					
					
M400U30		M600U30		M200U30	
Switch body	Ampere Rating	400	600	800	1200
	Base Part #	M400U	M600U	M800U	M1200U
	3-pole configurations	30, 12	30, 12	30, 12	30
Handles and Shafts	Direct Front Operation Locking Handle				
		HD400	HD800	HD800	HD1000
	External Front Operation				
	Pistol Style NEMA Type 1, 3R, 12	HB125, HB145, HB274			
	NEMA Type 4, 4X	HB125X, HB145X, HB274X			
	NEMA 4X Stainless Steel	HM125X, HM175X			
	Shaft— SAxxx (xxx = length in mm)	SFB185, SFB280, SFB325, SFB395, SFB535			
Alignment Ring (optional, for pistol-style handle)	ALRJF10				
B=Black. Substitute 'R' for 'B' if a red handle is desired. Ex. HR125					
Accessories	Fourth Poles				
		4P400	4P800	4P800	4P1250
Terminal Lugs					
	6 per package	LUG400 #2 - 600MCM	LUG800 2 x #2 600MCM	LUG800 2 x #2 600MCM	LUG1200 4 x #2 600MCM
Terminal Shrouds					
	3-pole	TS400-13	TS600-3	TS800-3	TS1600-13
	4-pole	TS400-14			TS1600-14
Shrouds with "-3" suffix are single shrouds that cover all three terminals. Shrouds with "-13" or "-14" are single pole shrouds with 3 or 4 per					
Auxiliary Contacts*					
	Normally Open	OA1G10	OA1G10	OA1G10	OA1G10
	Normally Closed	OA3G01	OA3G01	OA3G01	OA3G01
	Module for 8 aux. contacts	OEA28	OEA28	OEA28	OEA28
*Rated 2A max continuous @690VAC					

TECHNICAL DATA ACCORDING TO UL/cULus								
Part Number				M30U3	M60U3	M100U3	M200Uxx	
General Purpose Amp Rating	pf= 0.7...0.8	-5° to 40 °C	A	30	60	100	200	
Maximum Operating Voltage			V	600	600	600	600	
Max. horsepower rating / motor FLA current	pf= 0.4...0.5 Three phase	240 V	HP/A	10/28.0	20/54.0	30/80.0	75/192.0	
		480 V	HP/A	20/27.0	40/52.0	50/65.0	150/180.0	
		600 V	HP/A	30/32.0	40/41.0	50/52.0	200/192.0	
	Single phase	120 V	HP/A	2/24.0	3/34.0	5/56.0		
240 V		HP/A	5/28.0	7.5/40.0	15/68.0			
Short circuit rating with fuse	Maximum fuse size		A	60	150	150	200	400
	Fuse type	CC	kA					
	Fuse type	J	kA	50	50	50	200	65
	Fuse type	T	kA	50	50	50		
	Fuse type	RK1	kA					
	Fuse type	RK5	kA					
	Fuse type	L	kA					
	Fuse type	H	kA					
Maximum General Use, DC Ratings								
Current rating		at 250 VDC	A				200	
		at 600 VDC	A				100	
DC horsepower rating for 4-pole switch		at 600 VDC	HP				50	
DC horsepower rating for 2-pole switch	In open air	at 125 VDC	HP				20	
	In enclosure ²⁾	at 250 VDC	HP				-	
DC short circuit rating for 4-pole switch	with circuit breaker		kA				10	
DC short circuit rating for 2-pole switch	with circuit breaker at 250 VDC		kA				14	
	with circuit breaker at 600 VDC		kA				10	
	with class J fuse at 250 VDC		kA				100	
	... with fuse size		A				200	
endurances								
Min. electrical endurance, pf. 0.75...0.8			oper. cycles	6 000	6 000	6 000	6 000	
Mechanical endurance			operations	20 000	20 000	20 000	20 000	
Terminal lug kits				Integral	Integral	Integral	LUG-200	
Wire range			AWG	14-4	14-4	8-1/0	4-300MCM	
Torque		Wire tightening	lb. in	55	55	55	275	
		Lug mounting					72	
TECHNICAL DATA ACCORDING TO IEC 60947-3								
Rated insulation voltage and rated operational voltage AC20/DC20		Pollution degree 3	V	750	750	750	1 000	
Dielectric strength		50 Hz 1min.	kV	6	6	6	10	
Rated impulse withstand voltage			kV	8	8	8	12	
Rated operational current, AC-22A		up to 415 V	A	40	63	100	250	
		440...500 V	A	40	63	100	250	
		690 V	A	40	63	100	250	
Rated operational current, AC-23A		up to 415 V	A	40	63	80	250	
		440 V	A	40	63	65	250	
		500 V	A	40	63	60	250	
		690 V	A	40	63	40	250	
Rated conditional short-circuit current I_p (r.m.s.) and corresponding max. allowed cut-off current i_c . The cut-off current i_c refers to values listed by fuse manufacturers	I_p (r.m.s.)	50 kA	kA	16.5	16.5	16.5		
	Max. fuse size gG/aM	415 V	A	125/125	125/125	125/125		
	I_p (r.m.s.)	10 kA	kA	8.2	8.2	8.2		
	Max. fuse size gG/aM	690 V	A	125/100	125/100	125/100		
(single phase test acc. to IEC60269)	I_p (r.m.s.)	50 kA	kA	10	10	10	35	
	Max. fuse size gG/aM	690 V	A	63/63	63/63	63/63	355/315	
	at prospective SC-current	80 kA	kA				40.5	
	Max. fuse size gG/aM	690 V	A				355/315	
Rated short-time withstand current	r.m.s. -value I_{cw}	690 V, 1 s	kA	2.5	2.5	2.5	8	
Rated short circuit making capacity	Peak value I_{cm}	690 V/500 V	A	3.6	3.6	3.6	30	
Power loss / pole	At rated operational current		W	0.7	1.6	4.0	6.5	
Mechanical endurance	Divide by two for operation cycles		Oper.	20 000	20 000	20 000	20 000	
Weight without accessories		3-pole	kg	0.36	0.36	0.36	1.2	
		4-pole	kg	0.50	0.50	0.50	1.5	
1) UL Listed switches are also CSA Approved. 2) Fuse size 70A for RK5.								

TECHNICAL DATA ACCORDING TO UL/cULus							
Part Number				M400U	M600U	M800U	M1200U
General Purpose Amp Rating	pf= 0.7...0.8	-5° to 40 °C	A	400	600	800	1200
Maximum Operating Voltage			V	600	600	600	600
Max. horsepower rating / motor FLA current	pf= 0.4...0.5 Three phase	240 V	HP/A	125/312.0	200/480.0	200/602	200/602
		480 V	HP/A	250/302.0	450/515.0	500/590	500/590
		600 V	HP/A	350/338.0	500/472.0	500/472	500/472
	Single phase	120 V	HP/A				
240 V		HP/A					
Short circuit rating with fuse	Maximum fuse size		A	600	600 800	800	1200
	Fuse type	CC	kA				
	Fuse type	J	kA	100	100		
	Fuse type	T	kA		100		
	Fuse type	RK1	kA				
	Fuse type	RK5	kA		100	100	100
	Fuse type	L	kA				
Fuse type	H	kA					
Maximum General Use, DC Ratings							
Current rating		at 250 VDC	A	400	600		
		at 600 VDC	A	200	200		
DC horsepower rating for 4-pole switch		at 600 VDC	HP	50	-		
DC horsepower rating for 2-pole switch	In open air	at 125 VDC	HP	40	-		
	In enclosure ²⁾	at 250 VDC	HP	50	50		
DC short circuit rating for 4-pole switch	with circuit breaker		kA	10	10		
DC short circuit rating for 2-pole switch	with circuit breaker at 250 VDC		kA	14	18		
	with circuit breaker at 600 VDC		kA	10	10		
	with class J fuse at 250 VDC		kA	100	100		
	... with fuse size		A	400	500		
Endurances							
Min. electrical endurance, pf. 0.75...0.8			oper. cycles	1 000	1 000	500	500
Mechanical endurance			operations	16 000	10 000	6000	6000
Terminal lug kits				LUG400	LUG800	LUG800	LUG1200
Wire range			AWG	2 - 600MCM	2 x 2 - 600MCM	2 x 2 - 600MCM	4 x 2 - 600MCM
Torque		Wire tightening	lb. in	375	55	500	500
		Lug mounting		240	480	480	450-670
TECHNICAL DATA ACCORDING TO IEC 60947-3							
Rated insulation voltage and rated operational voltage AC20/DC20		Pollution degree 3	V	1 000	1 000	1 000	1 000
Dielectric strength		50 Hz 1min.	kV	10	10	10	10
Rated impulse withstand voltage			kV	12	12	12	12
Rated operational current, AC-22A		up to 415 V	A	400	800	1600	1600
		440...500 V	A	400	800	1600	1600
		690 V	A	400	800	1600	1600
Rated operational current, AC-23A		up to 415 V	A	400	800	1250	1250
		440 V	A	400	800	1250	1250
		500 V	A	400	800	1250	1250
		690 V	A	400	800	1250	1250
Rated conditional short-circuit current I_p (r.m.s.) and corresponding max. allowed cut-off current I_c . The cut-off current I_c refers to values listed by fuse manufacturers	I_p (r.m.s.)	50 kA	kA				
	Max. fuse size gG/aM	415 V	A				
	I_p (r.m.s.)	50 kA	kA				
	Max. fuse size gG/aM	690 V	A				
(single phase test acc. to IEC60269)	I_p (r.m.s.)	50 kA	kA	50.5	71.5		
	Max. fuse size gG/aM	690 V	A	500/500	800/1 000		
	at prospective SC-current	80 kA	kA	59	83.5		
	Max. fuse size gG/aM	690 V	A	500/500	800/1 000		
Rated short-time withstand current	r.m.s. -value I_{cw}	690 V, 1 s	kA	15	20	50	50
Rated short circuit making capacity	Peak value I_{cm}	690 V/500 V	A	65	80	110	110
Power loss / pole	At rated operational current		W	10	40	29	48
Mechanical endurance	Divide by two for operation cycles		Oper.	26 000	10 000		
Weight without accessories		3-pole	kg	2.2	5.2	15.2	15.2
		4-pole	kg	2.8	6.4		

1) UL Listed switches are also CSA Approved. 2) Fuse size 70A for RK5.



UL 98 Fusible

Disconnect Switches

DISCONNECT SWITCHES



Mersen's fusible disconnect switches are listed to UL 98 and bear the CE mark conforming to IEC 60947-3. They are "service entrance" devices capable of fully rated load-break and load-make. While long-term safety, reliability, and functionality are always paramount in the design of our products, these switches are also engineered to have the smallest footprint. The modular design allows placement of the handle anywhere amongst the poles. The fuse doors cannot open when the switch is in the "ON" position, and all switches are double-break, which isolates both fuse clips from voltage during fuse replacement. The switches' "Test" position allows actuation of the auxiliary contacts without main power. Power taps enable energizing a CPT or surge device without the need for a separate terminal block. A wide range of ergonomic handles and accessories is available.

CONFIGURATIONS:

*Not all configurations are available



Gearbox on the side Gearbox in the middle Side operated

Catalog number designation						
M Switch	60 Ampacity	J Type	3 Number of Poles/Left of handle	0 Number of Poles/Right of handle	— Revision	S Special Configuration
M = Mersen AC Switch	30-1200	CC = CC fused J = J fused L = L fused	1, 2, 3, 4, etc. (N = Neutral)	Blank = < 200A non-fused, 0, 2	Blank = 0	S = side-operated N = Non-fused switched Neutral F = Rod-Flange Actuated

RATINGS UL:

- **Volts:** 600VAC
- **Amps:** 30, 60, 100, 200, 400, 600, 800, and 1200A
- **Short-Circuit Current Rating (SCCR):** Up to 200kA with Class CC, J, or L Fuses

FEATURES/ BENEFITS:

- Multiple Configurations
- Power taps
- Adjustable shaft depth
- Fuse monitoring
- Double break, isolating live and load side of fuse
- Interlocked fuse doors

APPROVALS:

- All UL Fusible Disconnect Switches meet UL & CSA requirements
- UL listed guide WHTY, File E191605 for UL 98 (ratings from 30A to 1200A)
- IEC 60947-3



UL LISTED FRONT AND SIDE OPERATED



M30CC12
30A, CC fused, 3-pole with pole on left side of handle and 2 poles on right side



M60J30
60A, J fused, with 3 poles on left side of handle



M200J30 with HDF200
200A, J fused, 3 poles on left side of direct handle

Switch Body	Ampere Rating	30	60	100	200
	Base Part #	M30	M60	M100	M200
	Fuse Type	CC, J	J	J	J
	3- and 4-pole configurations	12, 22, 30F, 30S	12, 22, 22N, 30, 30F, 30S, 40, 40N	12, 22, 22N, 30, 30F, 30S, 40, 40N	30, 40
S = Side operated F = Rod-Flange actuated (Direct Side Operated Handles are included with 'S' option)					
Handles and Shafts	Direct Front Operation	HDF30	HDF200	HDF200	HDF200
	External Front Operation - Pistol style				
	NEMA Type 1, 3R, 12, IP65	HB45	HB65, HB80		
	NEMA Type 4, 4X	HB45X	HB65X, HB80X		
	NEMA 4X Stainless Steel	HM65X			
	B=Black. Substitute 'R' for 'B' if a red handle is desired. Ex. HR45				
	Shafts	SHAFT— SPAxxx (xxx = length in mm)			
		SPA130, SPA210, SPA290, SPA360, SPA430			
Accessories	Terminal Lugs	6 per package	Integral	Integral	LUG100 (#14 - 2/0) LUG200 (#6 - 300MCM)
	Terminal Shrouds	3-pole (3 single shrouds per package)	Integral	Integral	TSF160-13 TSF200-13
		4-pole (4 single shrouds per package)			TSF160-14 TSF200-14
	Shrouds with "-3" suffix are single shrouds that cover all three terminals. Shrouds with "-13" or "-14" are single pole shrouds with 3 or 4 per				
	Auxiliary Contacts*	NO	OA1G10, w/OSZ4	OA1G10	OA1G10
		NC	OA3G01, w/OSZ4	OA3G01	OA3G01
		NO, between poles	OA4B1C	N/A	N/A
		Mounting plate OA1G10/OA3G01	OSZ4	Not needed	Not needed
		Module for 8 aux. contacts	OEA28	OEA28	OEA28
	*Rated 2A max continuous @690VAC				
	Flange Operation for Cable Actuation	Cable Flange Handle, NEMA 12	FHC12	FHC12	FHC12
		Cable Flange Handle, NEMA 4X	FHC4X	FHC4X	FHC4X
		Bracket Assembly	FOM2	FOM3 for M60J12, FOM4 for M60J30	FOM4
		Cable for FHC handles	CABLE36*	CABLE36*	CABLE36*
	*Other cable lengths available: 48", 60", 72", 84", 96", 108". For example, CABLE108.				
	Flange Operation for Rod Actuation*	Flange bracket assembly	Incl with M30x30F	Incl with M60J30F	Incl with M100J30F
		Rod Flange handle NEMA 12	FHR12	FHR12	FHR12
		Rod Flange handle NEMA 4X	FHR4X	FHR4X	FHR4X
		Rod, 16, 21, 26 inch (ex. ROD16)	RODxx	RODxx	RODxx
	*These products have not been tested for UL Compliance				

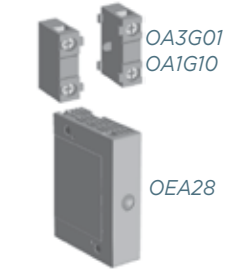

FOM4, FHC12, and CABLE36 with M200J30

DS

UL LISTED FRONT AND SIDE OPERATED



M400J30
400A, J fused, 3-pole with 3 poles on left side of handle



M800L30
800A, L fused, with 3 poles on left side of handle

Switch Body	Ampere Rating	400	600	800	1200
	Base Part #	M400	M600	M800	M1200
	Fuse Type	J	J	L	L
	3- and 4-pole configurations	12, 30, 40	12, 30, 40	12, 30, 40	30, 40
Handles and Shafts	Direct Front Operation				
		HDF400	HDF800T	HDF800T	HD1250T
	External Front Operation				
	NEMA Type 1, 3R, 12		HB125, HB145, HB274		
	NEMA Type 4, 4X		HB125X, HB145X, HB274X		
	NEMA 4X Stainless Steel		HM125X, HM175X		
	B=Black. Substitute 'R' for 'B' if a red handle is desired. Ex. HR125				
	Shafts				
	Shaft—SFBxxx (xxx = length in mm)	SFB185, SFB280, SFB325, SFB395, SFB535			
Accessories	Terminal Lugs				
	6 per package	LUG400 #2 - 600MCM	LUG800 2 x #2 600MCM	LUG800 2 x #2 600MCM	LUG1200 4 x #2 600MCM
	Terminal Shrouds				
	3-pole	TSF400-13	TSF600-3	TSF600-3	TSF1250-13
	Suffix "-3" indicates a single 3-pole shroud; Suffix "-13" indicates 3 single pole shrouds per package				
	Auxiliary Contacts*				
	Normally Open	OA1G10	OA1G10	OA1G10	OA1G10
	Normally Closed	OA3G01	OA3G01	OA3G01	OA3G01
	Module for 8 aux. contacts	OEA28	OEA28	OEA28	OEA28
	*Rated 2A max continuous @690VAC				

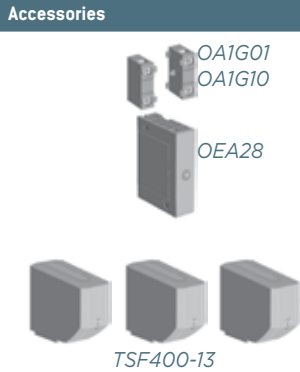

TECHNICAL DATA ACCORDING TO UL/cULus							
General Purpose Amp Rating	pf= 0.7...0.8	-5° to 40 °C	A	30	60	100	200
Maximum Operating Voltage			VAC	600	600	600	600
			VDC	250	250	250	250
Max. horsepower rating / motor FLA current	pf= 0.4...0.5 Three phase	240 V	HP/A	7.5/22.0	15/42.0	30/80.0	60/154.0
		480 V	HP/A	15/21.0	30/40.0	60/??0	125/156.0
		600 V	HP/A	20/22.0	50/52.0	75/??0	150/144.0
	Single phase	120 V	HP/A	2/24.0			
		240 V	HP/A	3/17.0			
Short circuit rating with fuse, 3- and 4- pole types			kA	200	200	200	200
	UL/CSA fuse size		A	30	60	100	200
	UL/CSA fuse type			J/CC	J	J	J
Endurances							
Min. electrical endurance, pf. 0.75...0.8			oper. cycles	6000	6000	6000	6000
Mechanical endurance			operations	20 000	20 000	20 000	16 000
Terminal lug kits				Integral	Integral	LUG100	LUG200
Wire range			AWG	#18-8	#14-4	#14-2/0	#4-300MCM
Torque		Wire tightening	lb. in	17	30/355	120	275
		Lug mounting	lb. in	N/A	N/A	50	72
TECHNICAL DATA ACCORDING TO IEC 60947-3							
Rated insulation voltage	Pollution degree 3		V	1 000	1 000	1 000	1 000
Dielectric strength		50 Hz 1min.	kV	10	10	10	10
Rated impulse withstand voltage			kV	12			12
Rated thermal current in ambient 40 °C /	In open air		A/W	32/3.5	63/7.5	160/12	200/17
max. fuse power dissipation ¹⁾	In enclosure ²⁾		A/W	32/3.5	63/7.5	160/10, 135/12	200/15
...with minimum cable cross section		Cu	mm ²	6	16	70	95
Rated operational current, AC-23A		up to 500 V	A	32	63	160	200
		690 V	A	32	63	160	200
Rated operational current, AC-23 ³⁾	The kW-ratings are accurate for three-phase 1500 R.P.M. standard asynchronous motors.	230 V	kW	7.5	18.5	45	60
		400 V	kW	15	30	75	110
		415 V	kW	15	30	75	110
		500 V	kW	18.5	37	90	132
		690 V	kW	22	55	132	200
Rated breaking capacity in category AC-23		up to 500 V	A	256	504	1280	1600
		690 V	A	256	504	1280	1600
Rated short-time withstand current, 1 s	r.m.s. -value	690 V, 1 s	kA	1	2.5	5	8
Power loss / pole	With rated current, without fuse		W	2	4	9	8
Weight without accessories	3-pole switch fuses		kg	0.7	1.3	1.5	2.6
	4-pole switch fuses		kg	0.9	1.6	1.8	
Built-in terminal size		Cu	mm ²	0.75...10	2.5...25		
Terminal bolt size (included)	Metric thread diameter x length		mm			M6x20	M8x25
Fuse-links bolts tightening torque			Nm			4	4

*) = Utilization category B

1) Ambient temperature 60°C: derating 20%

2) Mounting on "ceiling": derating 10%. Mounting on wall, horizontal fuses: derating 8%.

3) Some fuses limit these figures further. Starting current characteristics must be considered separately.

4) Approval pending

5) 30 lb.in with cable size #14-10, 35 lb.in with cable size #8-4

TECHNICAL DATA ACCORDING TO UL/cULus							
General Purpose Amp Rating	pf= 0.7...0.8	-5° to 40 °C	A	400	600	800	1200
Maximum Operating Voltage			VAC	600	600	600	600
			VDC	250	250	250	250
Max. horsepower rating / motor FLA current	pf= 0.4...0.5 Three phase	240 V	HP/A	125.0/312.0	200/480.0	250/602.0	250/602.0
		480 V	HP/A	250.0/302.0	400/477.0	500/590.0	500/590.0
		600 V	HP/A	350.0/336.0	500/472.0	500/472.0	500/472.0
	Single phase	120 V	HP/A				
		240 V	HP/A				
Short circuit rating with fuse, 3- and 4- pole types			kA	200	200	200	200
	UL/CSA fuse size		A	400	600	800	1200
	UL/CSA fuse type			J	J	L	L
Endurances							
Min. electrical endurance, pf. 0.75...0.8			oper. cycles	1 000	1 000	500	500
Mechanical endurance			operations	12 000	4 000	3 000	2 000
Terminal lug kits				LUG400	LUG800	LUG800	LUG1200
Wire range			AWG	#2-600MCM	{2}#2-600MCM	{2}#2-600MCM	{4}#2-600MCM
Torque		Wire tightening	lb.in	375	500	500	500
		Lug mounting	lb.in	240	480	480	480
TECHNICAL DATA ACCORDING TO IEC 60947-3							
Rated insulation voltage	Pollution degree 3		V	1 000	1 000	1 000	1 000
Dielectric strength		50 Hz 1min.	kV	10	10	10	10
Rated impulse withstand voltage			kV	12	12	12	12
Rated thermal current in ambient 40 °C /	In open air		A/W	400/45	630/60	800/65	1250/110
max. fuse power dissipation ¹⁾	In enclosure ²⁾		A/W	400/30	570/50	720/55	1000/85
...with minimum cable cross section		Cu	mm ²	240	2x185	2x240	2x400
Rated operational current, AC-23A		up to 500 V	A	400	630	800	1000 ^{*)}
		690 V	A	400	630	800	1000 ^{*)}
Rated operational current, AC-23 ³⁾	The kW-ratings are accurate for three-phase 1500 R.P.M. standard asynchronous motors.	230 V	kW	132	200	250	315 ^{*)}
		400 V	kW	220	355	450	560 ^{*)}
		415 V	kW	230	355	450	560 ^{*)}
		500 V	kW	280	450	560	710 ^{*)}
		690 V	kW	400	630	710	1000 ^{*)}
Rated breaking capacity in category AC-23		up to 500 V	A	3200	6400	6400	8000
		690 V	A	3200	6400	6400	8000
Rated short-time withstand current, 1 s	r.m.s. -value		kA	14	20	20	
Power loss / pole	With rated current, without fuse		W	30	46	75	75
Weight without accessories	3-pole switch fuses		kg	5.7	11.5	11.5	29
	4-pole switch fuses		kg				
Built-in terminal size		Cu	mm ²				
Terminal bolt size (included)	Metric thread diameter x length		mm	M10x30	M12x40	M12x40	M12x50
Fuse-links bolts tightening torque			Nm	20	40	40	40

*) = Utilization category B

1) Ambient temperature 60°C: derating 20%

2) Mounting on "ceiling": derating 10%. Mounting on wall, horizontal fuses: derating 8%.

3) Some fuses limit these figures further. Starting current characteristics must be considered separately.

4) Approval pending

5) 30 lb.in with cable size #14-10, 35 lb.in with cable size #8-4

PV-Rated

Disconnect Switches

DISCONNECT SWITCHES



Mersen offers a range of DC disconnect switches specially designed for PV applications, in one- and two-circuit configurations for both 1000V and 1500V DC applications. The technology inside the switch and the visible contacts allow a quick, safe, and reliable DC breaking at all current levels up to 1500VDC. The product is ready and simple to install independent of the polarity, with limited power losses, and a smaller footprint than competition.

APPLICATIONS:

- Medium and large power photovoltaic installations up to 1500VDC
- “Make and break” on load and provide safety isolation at string combiner box level

RATINGS:

- **Volts:** 1000 and 1500VDC
- **Amps:** IEC: 100 to 500A, UL98: 100 to 400A
- **Short-Circuit Current Rating (SCCR):** 5 to 10kA for higher ratings

FEATURES/ BENEFITS:

- IEC version and UL version
- Visible contacts
- Compact footprint
- Direct installation for floating polarity configuration
- Jumper bar available for grounded configuration

APPROVALS:

- UL98B File #E466972 WHVA
- IEC 60947-3 CE



DS

Catalog number designation

MD Switch	100 Ampacity	E Type	1 Number of Poles/Left of handle	1 Number of Poles/Right of handle	— Revision
MD = Mersen DC Switch	100-500A	E = IEC U = UL-listed V = 1500V	1, 2, 3	1, 2, 3	Blank = 0

UL 98B Listed DC Switches



MD100U11



MD100U22



MD250UV12







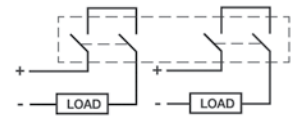
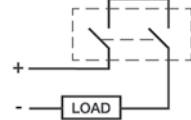
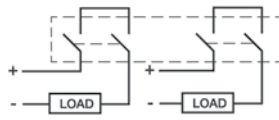
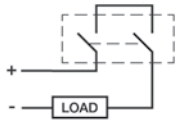

MD400U11



MD400U22

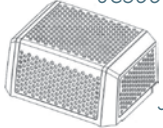

Switch Body	Ampere Rating	100	200	250	320	400
	1000VDC 2-pole Configuration	MD100U11	MD200U11	MD250U11	MD320U11	MD400U11
	1000VDC 2x2-pole Configuration	MD180U22	MD180U22*		MD320U22	MD400U22
	1500VDC 3-pole Configuration			MD250UV12	MD320UV12	MD400UV12
B=Black. Substitute 'R' for 'B' if a red handle is desired. Ex. HR45 *180A Rating						
Handles and Shafts	Direct Front Operation					
 <p>HDD400</p>  <p>HB125</p>	1000VDC	HDD250	HDD250	HDD250	HDD400	HDD400
	1500VDC	HDD400	HDD400	HDD400		
	External Pistol style					
	NEMA Type 1, 3R, 12	HB65, HB80		HB125, HB145		
NEMA Type 4, 4X	HB65X, HB80X		HB125X, HB145X			
B=Black. Substitute 'R' for 'B' if a red handle is desired. Ex. HR65						
Accessories	Shafts					
 <p>OA1G01 OA1G10</p>  <p>JC250</p>  <p>OEA28</p>  <p>JC500</p>  <p>JC500-2</p>	Shaft— SPAxxx (xxx = length in mm), SFBxxx (xxx = length in mm)	SPA130, SPA210, SPA290, SPA360, SPA430		SFB185, SFB280, SFB325, SFB395, SFB535		
	Auxiliary Contacts*					
	NO Right side mounting	OA1G10	OA1G10	OA1G10	OA1G10	OA1G10
	NC left side mounting	OA3G01	OA3G01	OA3G01	OA3G01	OA3G01
Module for SF aux. contacts	OEA28	OEA28	OEA28	OEA28	OEA28	
*Rated 2A max continuous @690VAC						
Terminal Shroud for Short Circuit Link						
For MDxxxU11, UV12	JC250	JC250	JC500	JC500	JC500	
For MDxxxU22	JC500-2	JC500-2	JC500-2	JC500-2	JC500-2	
Terminal Shroud for Lugs						
Kit of 4 Terminal Shrouds						
1 Terminal Shroud	TDS250S	TDS250S	TDS250S	TDS400	TDS400	

DS

IEC-RATED DC SWITCHES								
MD100E11	MD100E22	MD400EV12	MD400E22	MD400EV12	MD315EV33	MD315EV33	MD315EV33	MD315EV33
Switch Body	Ampere Rating	100	160	200	250	315	400	500
	1000VDC 2-pole Configuration	MD100E11	MD160E11	MD200E11	MD250E11	MD315E11	MD400E11	MD500E11
	1000VDC 2x2-pole Config.	MD100E22	MD160E22	MD200E22	MD250E22	MD315E22	MD400E22	MD500E22
	1500VDC 3-pole Configuration					MD315EV12	MD400EV12	MD500EV12
	1500VDC 2x3-pole Config.					MD315EV33	MD400EV33	MD500EV33
Handles and Shafts	Direct Front Operation							
		HDD250	HDD250	HDD250	HDD250	HDD400	HDD400	HDD400
	External Pistol Style							
	NEMA Type 1, 3R, 12	HB65, HB80				HB125, HB145		
	NEMA Type 4, 4X	HB65X, HB80X				HB125X, HB125X		
	B=Black. Substitute 'R' for 'B' if a red handle is desired. Ex. HR65							
	Shafts							
	Shaft — SPAxxx (xxx = length in mm)	SPA130, SPA210, SPA290, SPA360, SPA430				SFB185, SFB280, SFB325, SFB395, SFB535		
Accessories	Auxiliary Contacts*							
	NO Right side mounting	OA1G10	OA1G10	OA1G10	OA1G10	OA1G10	OA1G10	OA1G10
	NC left side mounting	OA3G01	OA3G01	OA3G01	OA3G01	OA3G01	OA3G01	OA3G01
	Module for SF aux. contacts	OEA28	OEA28	OEA28	OEA28	OEA28	OEA28	OEA28
	*Rated 2A max continuous @690VAC							
	Short Circuit Link							
	For MDxxxE22 and EV33					JUMP500-2	JUMP500-2	JUMP500-2
	For MDxxxE11, E22, EV12**	JUMP250	JUMP250	JUMP250	JUMP250	JUMP500	JUMP500	JUMP500
	**Shipped with one link per circuit							
	Terminal Shroud for Short Circuit Link							
	For JUMP500-2					JC500-2	JC500-2	JC500-2
	For JUMP250, JUMP500	JC250	JC250	JC250	JC250	JC500	JC500	JC500
	Terminal Shrouds for Lugs							
	Kit of 4 Terminal Shrouds	TS250-14	TS250-14	TS250-14	TS250-14			
	1 Terminal Shroud					TDS400	TDS400	TDS400
	A shorter version is available for DC Switches up to 250A. 1 piece per package: TDS250S							

DS

TECHNICAL DATA FOR 1000VDC-RATED SWITCHES

Technical data in accordance to UL 98B for switch-disconnectors
(Suitable for use in photovoltaic systems in accordance with article 690 of the NEC)

Switch Size			MD100U	MD200U	MD250U	MD315U	MD400U	MD250UV12	MD320UV12	MD400UV12
Voltage Rating		VDC	1000	1000	1000	1000	1000	1500	1500	1500
Current Rating		A	100	200 1)	250	320	400	250	320	400
Rated Ambient Temp.		°C	-20...+50	-20...+50	-20...+50	-20...+50	-20...+50	-20...+50	-20...+50	-20...+50
Short Circuit Rating		kA, 1000V	5	5	10	10	10	10	10	10
	Class of Fuse		Circuit breaker	Circuit breaker	Circuit breaker	Circuit breaker	Circuit breaker	Circuit breaker	Circuit breaker	Circuit breaker
Mechanical Endurance (Divide by 2 for operation cycles) Oper.			4000	4000	2000	2000	2000			
Terminal Lugs			LUG200	LUG200	LUG400	LUG400	LUG400	LUG400	LUG400	LUG400
Wire Range		MCM	#4-300	#4-300	#2-600	#2-600	#2-600	#2-600	#2-600	#2-600
Technical data according to IEC		Same as type	MD160E	MD250E	MD315E	MD400E	MD500E	MD315EV12	MD400EV12	MD500EV12

1) For 4 pole switches [double circuit use], the current rating at 1000 VDC is 180 A.

TECHNICAL DATA ACCORDING TO IEC 60947 FOR SWITCH-DISCONNECTORS

Switch Size		A	MD100E	MD160E	MD200E	MD250E	MD315E	MD400E	MD500E
Rated Insulation voltage U_i	Pollution degree 2	V	1500	1500	1500	1500	1500	1500	1500
	Pollution degree 3	V	1500	1500	1500	1500	1500	1500	1500
Rated impulse withstand	50 Hz 1 min	kV							
		kV	12	12	12	12	12	12	12
Rated thermal current I_{th} ...with minimum cable or bar cross section	In open air, normal conditions ¹⁾	A	100	160	200	250	315	400	630
	In enclosure 40°C	A	100	160	200	250	315	400	550
	In enclosure 60°C	A	100	160	200	250	315	400	440
	Cu	mm ²	35	70	95	120	185	240	240
Rated operational current / poles in series DC-21B	1000	V	100 / 2	160 / 2	200 / 2	250 / 2	315 / 2	400 / 2	500 / 2
			100 / 2x2	160 / 2x2	200 / 2x2	250 / 2x2	315 / 2x2	400 / 2x2	500 / 2x2
Rated short-time withstand current, 1000 V, 1 s, R.M.S. -value I_{sc}^{1000}		kA	5	5	5	5	10	10	10
Rated short circuit making capacity, 1000 V, Peak value I_{sm}		kA	5	5	5	5	10	10	10
Power loss / pole	At rated current	W	2	4	6	9,5	6	9,7	15,1
Cable size	Cu	mm ²							
Terminal bolt size	Metric thread diameter x length	mm	M8x25	M8x25	M8x25	M8x25	M10x30	M10x30	M12x40
Terminal tightening torque	Counter torque required	Nm	15-22	15-22	15-22	15-22	30-44	30-44	50-75

1) Normal conditions defined in IEC 60947-1-6.1

TECHNICAL DATA ACCORDING TO IEC 60947 FOR 1500VDC-RATED SWITCHES

Switch Size		A	MD315EV12	MD400EV12	MD500EV12	
Rated Insulation voltage U_i	Pollution degree 2	V	1500	1500	1500	
	Pollution degree 3	V	1500	1500	1500	
		kV	12	12	12	
Rated thermal current I_{th} ...with minimum cable or bar cross section	In open air, normal conditions ¹⁾	A	315	400	630	
	In enclosure 40°C	A	315	400	550	
	In enclosure 60°C	A	315	400	440	
	Cu	mm ²	185	240	240	
Rated operational current / poles in series DC-21B	1000	1 circuit	V	315 / 2	400 / 2	500 / 2
	1000	2 circuits	V	315 / 2	400 / 2	500 / 2
	1000	3 circuits	V	315 / 2	400 / 2	500 / 2
	1500	1 circuit	V	315 / 3	400 / 3	500 / 3
	1500	1 circuit	V	315 / 4	400 / 4	500 / 4
	1500	2 circuits	V	315 / 3	400 / 3	500 / 3
Rated short-time withstand current, 1500 V, 1 s	R.M.S. -value I_{sc}^{1500}	kA	10	10	10	
Rated short circuit making capacity, 1500 V	Peak value I_{sm}	kA	10	10	10	
Power loss / pole	At rated current	W	6	9,7	15,1	
Terminal bolt size	Metric thread dia. x length	mm	M 10x30	M 10x30	M 12x40	
Terminal tightening torque	Counter torque required	Nm	30-44	30-44	50-75	

1) Normal conditions defined in IEC 60947-1-6.1

Enclosed

Disconnect Switches

DISCONNECT SWITCHES



Mersen enclosed disconnect switches are designed to meet customer's requirements for compact and durable individual disconnecting means. Both fusible and non-fusible versions are available in a variety of enclosure types resulting in one of the largest available ranges in the industry. The enclosed disconnect switch range offers safety, ease of installation, space savings and operational convenience to end-users.

Mersen features NEMA style, Type 4X non-metallic and stainless steel enclosures that are extremely durable and provide the ultimate protection for harsh environments and conditions. These rugged enclosure types are often used in areas where "wash down" applications are required.

APPLICATIONS:

- Load break switching
- Separate disconnect means within sight of all motor loads to comply with NEC® Article 430
- Circuit isolation
- Service entrance ratings available
- Food processing
- Conveyor systems
- Harsh industrial environments

RATINGS:

Fusible

- **Volts:** 600VAC
- **Amps:** 30 to 800A

Non-Fusible

- **Volts:** 600VAC
- **Amps:** 16 to 1200A

- **Volts:** 600VDC

- **Amps:** 100 to 400A

HIGHLIGHTS:

- Suitable for use as motor disconnect
- Meets OSHA lockout/tagout requirements
- NEMA rated enclosures
- Knockouts provided
- Easy screw mounting
- Selector or pistol handles in black or red/yellow
- Clear ON/OFF indication

APPROVALS:

- UL 508A
- UL 508
- UL 98
- CSA
- IEC versions available



PART NUMBERING GUIDELINE (EXAMPLE)

ED	FS	30	3	R	S	0	-
Enclosure Type	Switch Type	Amp Rating	Number of Poles	Color of handle: R = Red/yellow B = Black	Type of handle: S = Selector P = Pistol	Auxiliary contacts: See chart below	Other options

Switch Type		Part Numbers	Auxiliary Contact Suffix				
			0	1	2	3	4
FS	UL 508 Non-Fused	M163 to M803	None	1 NO	1 NC	1 NO + NC	1 NO + NO
FC or SC	UL 98 Non-Fused	M30U to M1200U	None	1 NO	1 NC	1 NO + NC	1 NO + NO
FB	UL 98 Fused	MxxC, J, L	None	1 NO	1 NC	1 NO + NC	1 NO + NO

OTHER OPTIONS

Please consult factory for availability and suffix for any other options including:

- Neutral blocks (N)
- If terminal shrouds are necessary, add a "T" to the end of the part number.
- Special Request
 - Pilot lights
 - Push buttons
 - 2 or 3 position selector switches

ALL ENCLOSED SWITCHES ARE PROVIDED WITH A STANDARD INTEGRAL GROUND LUG

Box type	Switch type	Ground lug wire size
NEMA/UL	16 – 60A	{2} #4 – #14
NEMA/UL	80 – 125A	{2} 1/0 – #14
NEMA/UL	200 – 400A	{2} 600kcmil – #2
NEMA/UL	600A & above	Consult Factory

Note: EDFs 40A, 60A & 80A use grounding stud

ENCLOSURE APPLICATION INFORMATION

Enclosure Type		Intended Use and Description
NEMA	1	Indoor use primarily to provide a degree of protection against contact with the enclosed equipment and against a limited amount of falling dirt.
NEMA	3R	Intended for outdoor use primarily to provide a degree of protection against rain, sleet, and damage from external ice formation.
NEMA	12	Intended for indoor use primarily to provide a degree of protection against circulating dust, falling dirt, and dripping non-corrosive liquids.
NEMA	4	Intended for indoor or outdoor use primarily to provide a degree of protection against windblown dust and rain, splashing water, hose-directed water, and damage from external ice formation.
NEMA	4X	Intended for indoor or outdoor use primarily to provide a degree of protection against corrosion, wind blown dust and rain, splashing water, hose-directed water, and damage from ice formation.
IEC	IP65	Total protection against dust and protected against water jets from any hosed direction.

NEMA ENCLOSURE 3 Pole, 600V 30-1200A, Non-fused		1	3R	12	4	4X Stainless	4X Non-Metallic	
Ampere Rating (A)		Catalog Numbers						
UL 508	16	Special compact polycarbonate enclosures					EJM16BS0S	
	30	Special compact polycarbonate enclosures					EJM30BS0	
	60	Special compact polycarbonate enclosures					EJM60BS0	
	16	EAFS163RS0	EFFS163RS0	ECFS163RS0	EHFS163RS0	EBFS163RS0	EDFS163RS0	
	25	EAFS253RS0	EFFS253RS0	ECFS253RS0	EHFS253RS0	EBFS253RS0	EDFS253RS0	
	30	EAFS303RS0	EFFS303RS0	ECFS303RS0	EHFS303RS0	EBFS303RS0	EDFS303RS0	
	40	Special hinged cover, SS				EBFS403RS0-H		
	40	EAFS403RS0	EFFS403RS0	ECFS403RS0	EHFS403RS0	EBFS403RS0	EDFS403RS0	
	60	EAFS603RPO	EFFS603RPO	ECFS603RPO	EHFS603RPO	EBFS603RPO	EDFS603RPO	
UL 98	80	EAFS803RPO	EFFS803RPO	ECFS803RPO	EHFS803RPO	EBFS803RPO	EGFS803RPO	
	30	E AFC303RPO	EFFC303RPO	ECFC303RPO	EHFC303RPO	EBFC303RPO	EGFC303RPO	
	60	E AFC603RPO	EFFC603RPO	ECFC603RPO	EHFC603RPO	EBFC603RPO	EGFC603RPO	
	100 50	E AFC1003RPO	EFFC1003RPO	ECFC1003RPO	EHFC1003RPO	EBFC1003RPO	EGFC1003RPO	
	200	E AFC2003RPO	EFFC2003RPO	ECFC2003RPO	EHFC2003RPO	EBFC2003RPO	EGFC2003RPO	
	400	E AFC4003RPO	EFFC4003RPO	ECFC4003RPO	EHFC4003RPO	EBFC4003RPO	EGFC4003RPO	
	600	E ASC6003RPO	EFSC6003RPO	ECSC6003RPO	EHSC6003RPO	EBSC6003RPO	EGSC6003RPO	
	800	E ASC8003RPO	EFSC8003RPO	ECSC8003RPO	EHSC8003RPO	EBSC8003RPO	EGSC8003RPO	
	1000	E ASC10003RPO	EFSC10003RPO	ECSC10003RPO	EHSC10003RPO	EBSC10003RPO	EGSC10003RPO	
1200	E ASC12003RPO	EFSC12003RPO	ECSC12003RPO	EHSC12003RPO	EBSC12003RPO	EGSC12003RPO		
NEMA ENCLOSURE 3 Pole, 600V 30-800A, Fused		1	3R	12	4	4X Stainless	4X Non-Metallic	
Ampere Rating (A)		Fuse Type	Catalog Numbers					
UL 98	30, compact	CC	EAFBCC303RPO	EFBCC303RPO	ECFBCC303RPO	EHFBCC303RPO	EBFBCC303RPO	EGFBCC303RPO
	30	J	EAFBX303RPO	EFBX303RPO	ECFBX303RPO	EHFBX303RPO	EBFBX303RPO	EGFBX303RPO
	60	J	EAFBX603RPO	EFBX603RPO	ECFBX603RPO	EHFBX603RPO	EBFBX603RPO	EGFBX603RPO
	100	J	EAFBX1003RPO	EFBX1003RPO	ECFBX1003RPO	EHFBX1003RPO	EBFBX1003RPO	EGFBX1003RPO
	200	J	EAFBX2003RPO	EFBX2003RPO	ECFBX2003RPO	EHFBX2003RPO	EBFBX2003RPO	EGFBX2003RPO
	400	J	EAFBJ4003RPO	EFBJ4003RPO	ECFBJ4003RPO	EHFBJ4003RPO	EBFBJ4003RPO	EGFBJ4003RPO
	600	J	EAFBJ6003RPO	EFBJ6003RPO	ECFBJ6003RPO	EHFBJ6003RPO	EBFBJ6003RPO	EGFBJ6003RPO
	800	L	EAFBL8003RPO	EFBL8003RPO	ECFBL8003RPO	EHFBL8003RPO	EBFBL8003RPO	EGFBL8003RPO

Notes: Each of the above enclosed switches are listed having a red/yellow handle. Simply replace the "RS" or "RP" with a "BS" or "BP" to receive with a black handle. The non-metallic enclosures are comprised of "ED" polycarbonate and "EG" polyester fiberglass.

Switch Rating	Enclosure Type	H height (in)	W width (in)	D depth (in)	MH mounting height (in)	MW mounting width (in)	Shipping Weight (lbs)	Figure No.
16-40A [M163-M403] UL508	1	8	8	6	5	7	10	2
	3R	8	8	6	9	3	11	1
	12	8	6	6	8.75	4	7	1
	4	5.91	5.91	4.72	5.2	3.35	7	2
	4X Stainless	5.91	5.91	4.72	5.2	3.35	7	2
	4X Non-Metallic	7	5	5	6.18	4.21	2	2
60A [M633] UL508	1	8	8	6	5	7	10	2
	3R	8	8	6	9	3	10	1
	12	8	6	6	8.75	4	7	1
	4	7.87	5.91	4.72	7.17	3.35	7	2
	4X Stainless	7.87	5.91	4.72	7.17	3.35	7	2
	4X Non-Metallic	7	5	5	6.18	4.21	4	2
80A [M803] UL508	1	10	8	6	7	7	10.6	2
	3R	10	8	6	11	3	11.1	1
	12	10	8	6	10.75	6	12.3	1
	4	9.84	7.87	5.91	9.13	5.31	9.8	2
	4X Stainless	9.84	7.87	5.91	9.13	5.31	9.8	2
	4X Non-Metallic	11.3	9.31	5.43	10.75	6	6	1
100A [M100U3] UL98	1	10	8	6	7	7	10.6	2
	3R	10	8	6	11	3	11.1	1
	12	10	8	6	10.75	6	12.3	1
	4	10	8	6	10.75	6	11.8	1
	4X Stainless	9.84	7.87	5.91	9.13	5.31	9.8	2
	4X Non-Metallic	11.31	9.31	5.43	10.75	6.02	7.6	1

DIMENSIONS (IN / MM)

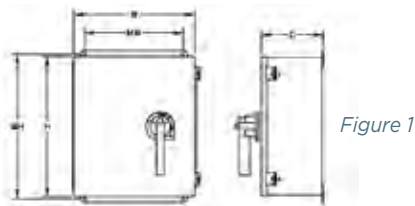

Figure 1

EJM16BS0S & EJM30BSx (enclosure size 1)

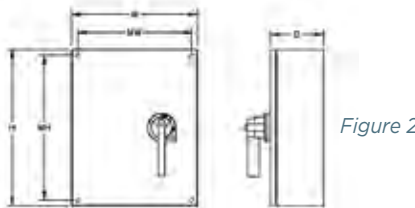
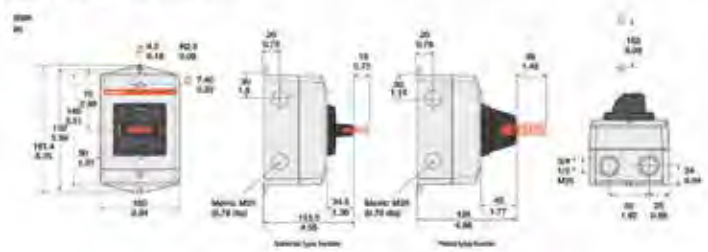

Figure 2

EJM60BSx (enclosure size 2)



EJM60BPx (enclosure size 2)



DS

Switch Rating	Enclosure Type	H height (in)	W width (in)	D depth (in)	MH mounting height (in)	MW mounting width (in)	Shipping Weight (lbs)	Figure No.
30A (M30U3) UL98	1	8	8	6	5	5	9.3	2
	3R	8	8	6	9	3	10.2	1
	12	7.87	5.91	4.72	5.2	3.35	7.6	1
	4	7.87	5.91	4.72	5.2	3.35	7.6	1
	4X Stainless	9.844	7.87	5.91	9.13	5.31	10.1	2
	4X Non-Metallic	9.3	7.31	4.96	8.74	4.01	6.2	1
60A (M60U3) UL98	1	12	12	6	9	11	16	2
	3R	12	10	6	13	3	17.6	1
	12	12	12	6	12.75	10	21.6	1
	4	12	12	6	12.75	10	21.9	1
	4X Stainless	11.81	9.84	5.91	11.1	7.28	17.4	2
	4X Non-Metallic	13.3	11.29	7.1	12.75	8.01	12.9	1
200A (M200U3) UL98	1	30	20	8.62	27.5	15	68.6	2
	3R	30	14	8	31	13	88.6	1
	12	30	20	8	28.5	18.5	70.1	2
	4	30	20	8	28.5	18.5	70.1	2
	4X Stainless	30	20	10	28.5	18.5	71	1
	4X Non-Metallic	32.87	25	11.81	34.72	22.91	59.3	1

Note: Dimensions are subject to change! Please consult factory for verification.

Switch Rating	Enclosure Type	H height (in)	W width (in)	D depth (in)	MH mounting height (in)	MW mounting width (in)	Shipping Weight (lbs)	Figure No.
30A (M30CC12) UL 98	1	8	8	6	5	7	9.4	2
	3R	8	8	6	9	3	10.3	1
	12	9.84	7.87	5.91	9.13	5.31	10.8	1
	4	9.84	7.87	5.91	9.13	5.31	10.8	1
	4X Stainless	9.84	7.87	5.91	9.13	5.31	11.3	2
	4X Non-Metallic	11.31	9.31	6.93	10.75	6.02	9.7	1
30A (M30J30) UL 98	1	12	12	8	9	11	18.3	2
	3R	12	12	10	13	3	23.2	1
	12	12	10	8	12.75	8	14.4	1
	4	13.78	11.81	7.87	13.07	9.25	22.4	2
	4X Stainless	13.78	11.81	7.87	13.07	9.25	24.3	2
	4X Non-Metallic	11.31	9.31	6.93	10.75	6.02	9.7	1
60A (M60J30) UL 98	1	12	12	8	9	11	18.2	2
	3R	12	12	10	13	5	23.1	1
	12	12	10	8	12.75	8	14.6	1
	4	13.78	11.81	7.87	13.07	9.25	24.2	2
	4X Stainless	13.78	11.81	7.87	13.07	9.25	24.2	2
	4X Non-Metallic	15.32	13.3	8.19	14.75	10	17.5	1
100A (M100J30) UL 98	1	20	16	8.62	17.88	11	35.2	2
	3R	18	18	10	19	13	41.3	1
	12	20	16	8	21.24	10	35.2	1
	4	20	16	8	18.5	14.5	39	2
	4X Stainless	20	16	8	18.5	14.5	38.1	2
	4X Non-Metallic	19.31	17.31	9.58	18.74	12	25.6	1
200A (M200J30) UL 98	1	24	20	8.62	21.96	12.76	56.6	2
	3R	24	24	10	25	13	61.2	1
	12	24	20	8	25.24	14	51	1
	4	24	20	8	22.5	18.5	49.5	2
	4X Stainless	24	20	8	22.5	18.5	50.5	2
	4X Non-Metallic	28.94	21	10.63	30.79	18.97	46.3	1

Note: Dimensions are subject to change! Please consult factory for verification.

DS



Your problem: You need to achieve code compliance and protect critical power operations with selective coordination. You need a UL Listed industrial control panel that offers remote load-break disconnection capability to emergency circuits.

Our solution: Mersen offers a fully customizable Fused Coordination Panelboard that can simplify the process of achieving code compliance for designers. Mersen's Fusible Shunt Trip Switch has an array of available options that allow for maximum functionality to be built into a single compact panel. The products are custom built to your exact specifications.

Want more information fast? For more technical or application-specific information, please call our Engineered Products experts at 978-465-4853 or visit our website at ep.mersen.com.

Engineered Solutions

SYSTEMS CUSTOM
ENGINEERED TO YOUR
SPECIFICATIONS

- Fused Coordination Panelboards ES 2
- Fusible Shunt Trip Switch . . . ES 4

ES



Fused Coordination Panelboards

ENGINEERED SOLUTIONS

MEET CODE REQUIREMENTS WITH MERSEN'S FUSED COORDINATION PANELBOARDS (MFCP)

The next generation of Fused Coordination Panelboards is here with coordinated protection between overloads and short circuits. Mersen's Fused Coordination Panelboard (MFCP) does not require fuse replacement on common overload conditions and branch circuits can simply be reset. Mersen's Amp-Trap 2000® class CC and class J fuses ensure minimal fuse let-thru energies and makes it easy to provide system coordination with our easy 2:1 coordination ratios for short circuits. Mersen's fused selective coordination panelboard is a UL67 listed panelboard that utilizes our commonly available class CC and J fuses.



FEATURES:

Branch Circuit Protection:

- UL Fuse/Circuit Breaker combination
- Resettable overload protection
- True class J and CC protection

Only Three Branch Fuse Sizes:

- 15A to 30A → ATDR30
- 35A to 60A → AJT60
- 70A to 100A → AJT100

Width:

- 20" wide

Main Options:

- Main Lug Only (MLO)
- Main non-fused switch
- Main non-fused switch with fuses
- Up to 42 Branch Circuits per Panel

Main Bus:

- Standard silver-plated copper, with optional tin-plated aluminum

Enclosures:

- NEMA 1, 12, 3R

Optional Features:

- UL 1449 Listed surge protection devices (required per NEC 700.8)
- Blown fuse indication (30A, 60A)

Mersen fused coordination panelboards are custom designed products. For catalog number selection please consult factory.

RATINGS:

- **Volts:** 120/208V, 3Ø, 4-wire; 120/240V, 1Ø, 3-wire; 277/480V, 3Ø, 4-wire; 347/600V, 3Ø, 4-wire
- **Amps:** Main Bus Ampacity ranges from 250A to 400A
- **Number of Circuits:** Up to 2 circuits
- **SCCR:** 200kA@600V

APPROVALS:

- UL 67 Listed Panelboard
- UL 50 Listed Enclosure
- Meets NEC® selective coordination code requirements for the following power systems:
 - 700.8 (Emergency)
 - 700.27 (Legally Required Standby)
 - 708.54 (Critical Operations)

STANDARD PANEL HIGHLIGHTS

- Easy selectivity ratios with upstream fuses
- Voltage: 120/208, 120/240, 277/480, 347/600
- Main Bus: 250A or 400A
- Main Disconnect: MLO, Fused Main or Non-Fused Main
- SCCR: 200kA
- Surge Protection (SPD) optional
- Up to 42 branch circuits per panel
- Standard 20" wide
- Feed through lugs optional
- Surface mount
- Uses commonly available class CC & J fuses

MAIN

- Up to 400A Fused Main Disconnect
- Allows for panel isolation
- Lockout provision
- Visible contacts
- Interlocked with cover

AJT AMP-TRAP 2000® FUSES MAIN FUSE

- Time Delay
- 2:1 coordination ratio
- 600VAC interrupting rating 200kA

BRANCH CIRCUITS

- Circuit breaker opens overloads up to 2 times circuit rating
- ATDR, AJT fuses open short circuit currents
- Fuseholder interlocked to prevent opening while energized
- Circuits up through 100A 1, 2 & 3 pole
- True Class J and CC protection

DIMENSIONS (STANDARD NEMA 1 ENCLOSURES)

For standard panels:

Width = 20 inches Depth = 6 inches

Height varies depending on number of circuits and main options.

NEMA 1 ENCLOSURE SPECIFICATIONS

- Tub: Galvanized unpainted steel. One endwall is provided with knockouts, and the other endwall is blank.
- Door: Equipped directory card, flush mount lock
- Trim and Door Finish: ANSI 49 grey baked enamel electrodeposited over cleaned, phosphatized steel

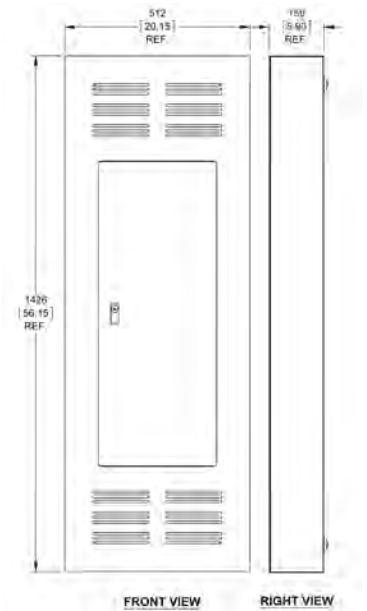

HIGHER RATED PANELS AND BRANCHES

For panels with circuits requiring ratings greater than 100A, Mersen offers a 38" wide panel with fusible switches for over-current protection. These panels can house up to two 20-circuit MFCP panels within it, in addition to fusible switches of up to 600A in various combinations.

- Main Bus Ratings: 600A, 800A, 1200A
- Main Device Ratings: MLO, Fused main disconnect of 600A, or 800A
- Fusible Branch Device Ratings*: 200A, 400A, 600A

*Branch ratings can be fused at standard fuse size increments in between these ratings and meet 2:1 coordination ratios.



Fusible Shunt Trip Switch

Cylindrical Fuse-Links

ENGINEERED SOLUTIONS

EMERGENCY SAFETY EQUIPMENT



Mersen's fusible shunt trip switch is a UL Listed industrial control panel offering remote load-break disconnection capability to emergency circuits. An array of available options allows for maximum functionality to be built into a single compact panel. Panels built for elevator applications feature control transformers (fusing both primary and secondary sides), a fire safety interface relay with a fire alarm voltage monitoring relay, and mechanically interlocked auxiliary contacts. Use of Mersen's Amp-Trap 2000® AJT Class J fuses permits easy selective coordination, while providing the panel and its components with superior current limitation and the ability to withstand high fault conditions. AJT fuses provide added system reliability since no maintenance or periodic testing is required as with other electromechanical overcurrent devices.

APPLICATIONS:

- Elevator controls
- Building emergency systems
- Data processing rooms

RATINGS:

- **Volts:** 208VAC, 240VAC, 480VAC, 600VAC. DC ratings available; consult factory.
- **Amps:** 30A, 60A, 100A, 200A, 400A
- **SCCR:** Varies depending on system voltage and ampere rating. See table on following page.

APPROVALS:

- cUL 508A Listed Industrial Control Panel, File E233863

ES SERIES - FUSIBLE SHUNT TRIP DISCONNECT SWITCH

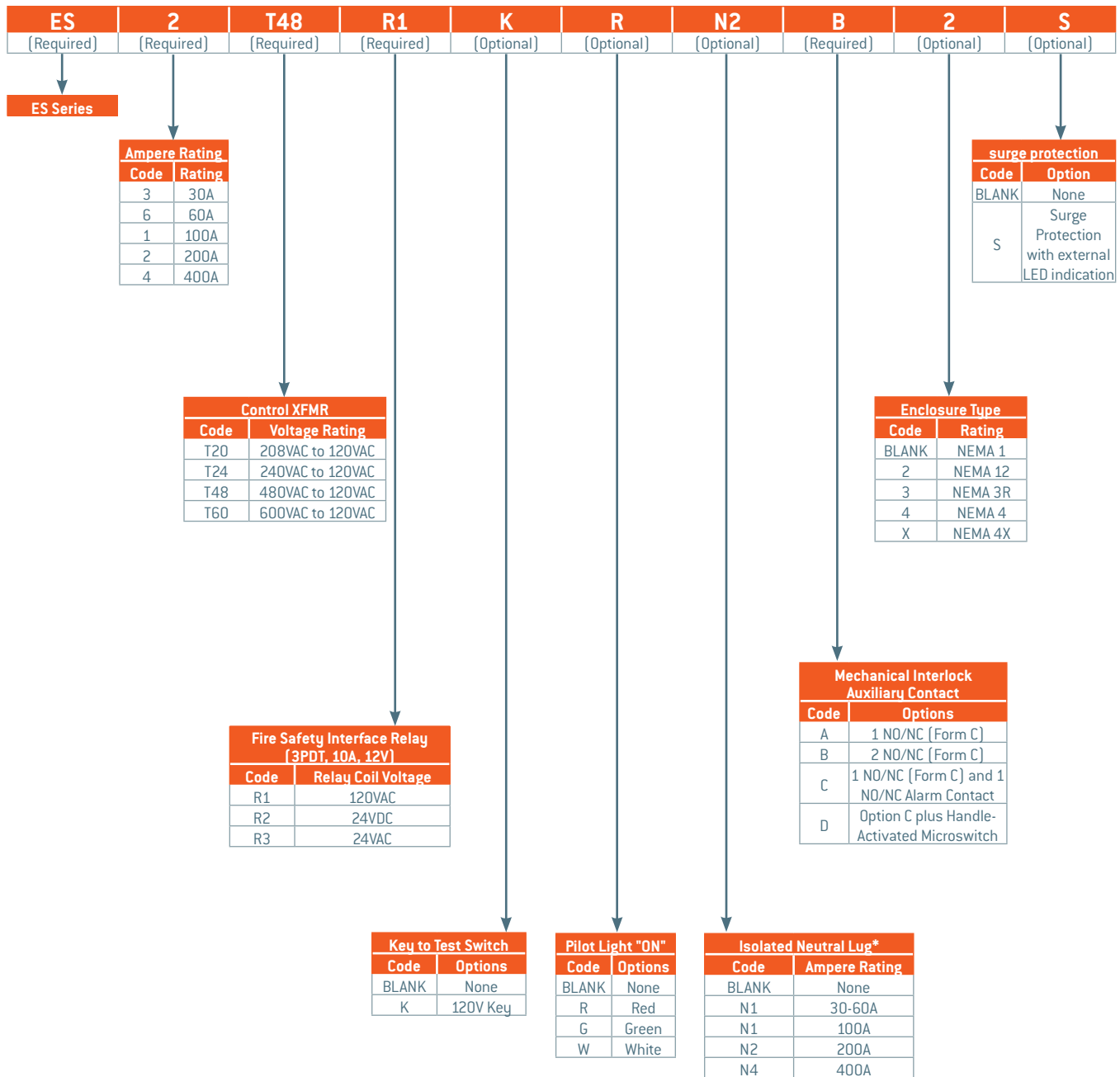

Fire Alarm Voltage Monitoring Relay included in all Mersen offerings. No additional part suffixes required. (Competitor Options F1 and F3)

*Neutral lug rating should be greater than or equal to the switch ampere rating. For 200% lug over sizing, select next higher rating. N4 is suitable for 200% over sizing at 400A.

Highlights

- Shunt trip switch – allows for tripping of the main line power via remote signal
- Fused switch – provides high current-limitation and short circuit withstand
- Padlockable handle – allows panel to be locked with switch in the off position ensuring load side power isolation during servicing

Optional Features

- Primary Voltage (208, 240, 480 or 600 VAC)
- Fire safety relay for control interface (3PDT Relay, choice of Coil Voltage: 120 VAC, 24 VDC or 24VAC)
- Oil-tight key switch to test 2 position selector switch
- Oil-tight power enabled indicator light (choice of colors: red, green or white)
- Isolated neutral lug – 100%. Oversized 200% for excessive Non-Linear loads
- Auxiliary and alarm contacts are both Form C contacts. The auxiliary contacts change state when the switch is in the on position. Alarm contacts change state when the switch is in the tripped position. The alarm contact is located in place of the second auxiliary contact
- NEMA 12, 3R, 4 or 4X enclosure available
- DC Shunt Trip Switch Version Available – Consult Factory

Dimensions and Optional Neutral Lug Sizes

Ampere Rating (A)	30	60	100	200	400
Voltage	H x W x D	H x W x D	H x W x D	H x W x D	H x W x D
208 VAC 3 (1)	24 x 20 x 8	24 x 20 x 8	24 x 20 x 8	30 x 24 x 8	36 x 30 x 8
240 VAC 3 (1)	24 x 20 x 8	24 x 20 x 8	24 x 20 x 8	30 x 24 x 8	36 x 30 x 8
480 VAC 3 (1)	24 x 20 x 8	24 x 20 x 8	24 x 20 x 8	30 x 24 x 8	36 x 30 x 8
600 VAC 3 (1)	24 x 20 x 8	24 x 20 x 8	24 x 20 x 8	30 x 24 x 8	36 x 30 x 8
Neutral Lug Size	2/0 - #14	2/0 - #14	2/0 - #14	350 - #6	2 x 500 - #4

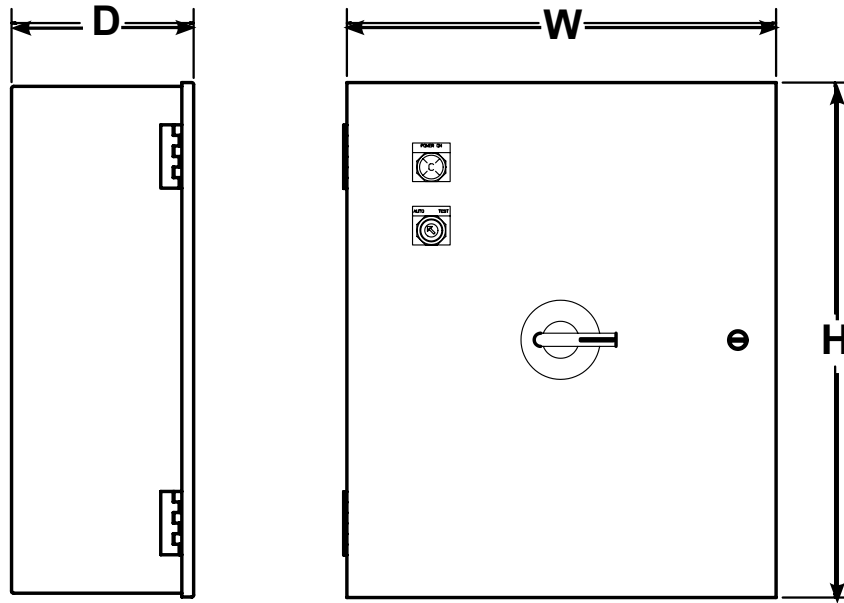

Short-Circuit Current Ratings (BASED ON UL489 STANDARDS)

AMP	RMS SYMMETRICAL AMPERES (kA)		
	UL A.I.R.		
	VOLTS (AC)		
	240	480	600
30	65	25	18
60	65	25	18
100	65	25	18
200	65	35	22
400	65	35	25



Your problem: Whether your objective is optimum protection of motor control equipment, power or control transformers, cable wiring, or lighting and heating circuits — you need fast, accurate information to do the job right. Problem is, not all electrical pros have the same familiarity with circuit protection theories and practices.

Our solution: Every application has its unique challenges. But you'll find the path to a basic understanding of applied circuit protection principles in our Applications section. Be it a glossary of relevant electrical terms, an introduction to fuse construction, guidance on reading and applying Peak Let-thru curves, or a look at the most common applications.

Want more information fast? For more technical or application-specific information, please call our Applications Engineering experts at 978-465-4853 or visit our website at ep.mersen.com.

Application Information

**NEED TO KNOW HOW?
YOU'VE TURNED TO
THE RIGHT PLACE...
LITERALLY**

- Definitions AP 2
- Fuse Descriptions AP 4
- Fuse Construction & Operation AP 4
- How to Read a Time Current Curve. AP 5
- Low Voltage Motor Protection AP 6
- Transformer Protection AP 11
 - General. AP 11
 - Low Voltage Primary Protection AP 11
 - Primary and Secondary Fuses for LV Transformers AP 12
 - Control Transformers. AP 13
 - MV Transformers AP 14
- Let-Thru Current & I²T. AP 20
- Fuse Let-Thru Current Tables. AP 21
- Capacitor Protection AP 27
- Cable Protection AP 29
- Motor Starter General Info. . AP 30
- Auxiliary Contacts. AP 31
- Selectivity Between Fuses. . AP 32
- Short Circuit Calculations . . AP 33
- Short Circuit Rating AP 34
- 11 Reasons for Using Current-Limiting Fuses. AP 34
- Fuse Obsolescence. AP 35
- Suggested Fuse Specifications. AP 36



Ampacity

The current a conductor can carry continuously without exceeding its temperature rating. Ampacity is a function of cable size, insulation type and the conditions of use.

Ampere Rating

The continuous current carrying capability of a fuse under defined laboratory conditions. The ampere rating is marked on each fuse. Class L fuses and E rated fuses may be loaded to 100% of their ampere rating. For all other fuses, continuous load current should not exceed 80% of fuse ampere rating.

Available Fault Current

The maximum short circuit current that can flow in an unprotected circuit.

Bolt-in Fuse

A fuse which is intended to be bolted directly to bus bars, contact pads or fuse blocks.

Contacts

The external live parts of the fuse which provide continuity between the fuse and the balance of the circuit. Also referred to as ferrules, blades or terminals.

Coordination

The use of overcurrent protective devices which will isolate only that portion of an electrical system which has been overloaded or faulted. See Selectivity.

Current-Limiting Fuse

A fuse which will limit both the magnitude and duration of current flow under short circuit conditions.

Current-Limiting Range

The available fault current a fuse will clear in less than 1/2 cycle, thus limiting the actual magnitude of current flow.

Dual Element Fuse

Often confused with time delay, dual element is a term describing fuse element construction. A fuse having two current responsive elements in series.

Element

A calibrated conductor inside a fuse which melts when subjected to excessive current. The element is enclosed by the fuse body and may be surrounded by an arc-quenching medium such as silica sand. The element is sometimes referred to as a link.

Fault

An accidental condition in which a current path becomes available which by-passes the connected load.

Fault Current

The amount of current flowing in a faulted circuit.

Fuse

An overcurrent protective device containing a calibrated current carrying member which melts and opens a circuit under specified overcurrent conditions.

I²t (Ampere Squared Seconds)

A measure of the thermal energy associated with current flow. I²t is equal to $(I_{RMS})^2 \times t$, where t is the duration of current flow in seconds.

Clearing I²t is the total I²t passed by a fuse as the fuse clears a fault, with t being equal to the time elapsed from the initiation of the fault to the instant the fault has been cleared.

Melting I²t is the minimum I²t required to melt the fuse element.

Interrupting Rating (Abbreviated I.R.)

The maximum current a fuse can safely interrupt. Some special purpose fuses may also have a "Minimum Interrupting Rating". This defines the minimum current that a fuse can safely interrupt.

Kiloamperes (abbreviated kA)

1,000 amperes.

Limiting or Back-up Fuse

A special purpose fuse which is intended to provide short circuit protection only.

Overcurrent

Any current in excess of conductor ampacity or equipment continuous current rating.

Overload

The operation of conductors or equipment at a current level that will cause damage if allowed to persist.

Peak Let-Thru Current (I_p)

The maximum instantaneous current passed by a current-limiting fuse when clearing a fault current of specified magnitude.

Rejection Fuse Block

A fuse block which will only accept fuses of a specific UL class. Rejection is a safety feature intended to prevent the insertion of a fuse with an inadequate voltage or interrupting rating.

Rejection Fuse

A current-limiting fuse with high interrupting rating and with unique dimensions or mounting provisions.

Renewable Fuse

A fuse which can be restored for service by the replacement of its element.

Renewable Element or Link

The field-replaceable element of a renewable fuse. Also referred to as a renewable link.

Selectivity

A main fuse and a branch fuse are said to be selective if the branch fuse will clear all overcurrent conditions before the main fuse opens. Selectivity is desirable because it limits outage to that portion of the circuit which has been overloaded or faulted. Also called selective coordination.

Semiconductor Fuse

An extremely fast acting fuse intended for the protection of power semiconductors. Sometimes referred to as a rectifier or ultra fast fuse.

Short Circuit

Excessive current flow caused by insulation breakdown or wiring error.

Threshold Current

The minimum available fault current at which a fuse is current limiting.

Time-Delay Fuse

A fuse which will carry an overcurrent of a specified magnitude for a minimum specified time without opening. The specified current and time requirements are defined in the UL/CSA/NOM 248 fuse standards.

Voltage Rating

The maximum voltage at which a fuse is designed to operate. Voltage ratings are assumed to be for AC unless specifically labeled as DC.

High Voltage (over 34,500V)

Expulsion-Type power fuses are available for nominal voltages of 46, 69, 115, 138 and 161kV in current ratings up to 400 amperes. ANSI (American National Standards Institute) Standards are followed.

Medium Voltage (601-34,500V)**Current-Limiting or Expulsion-Type Power Fuses**

are general purpose fuses available for nominal voltages of 2.4, 2.75, 4.16, 5.5, 7.2, 8.25, 14.4, 15.5, 23 and 34.5kV in current ratings up to 720 amperes. ANSI and UL Standards are followed.

Current-Limiting Motor Starter Fuses

are available for nominal voltages of 2.4, 4.8 and 7.2kV in current ratings up to 36R (650A). These are special purpose R-Rated fuses for motor short circuit protection only (back-up fuses) and are not full-range power fuses. ANSI and UL Standards are followed.

PT Fuses (Potential Transformers)

require current limiting fuses or equivalent on the primary connection side. Standard PT primary voltages range from 2.4kV to 36kV. Since the power requirement is low (for relays, metering, etc.) fuses of the proper voltage are applied in the 1/2 to 5 ampere range. Several voltage ratings are available, physical sizes vary among manufacturers.

Low Voltage (600V or less)

Many types of low voltage fuses are classified and identified for use in 125, 250, 300, 480, or 600V circuits. UL/CSA/NOM standards are followed. Common types are briefly summarized in the chart on the next page.

SUMMARY OF LOW VOLTAGE FUSES

Fuse Type	Voltage	Ampere Rating	Interrupting Rating – kA	Mersen Part #	UL
Class CC	600VAC 300VDC 600VDC	0-30 0-30 0-30	200 100 100	ATDR, ATQR, ATMR ATDR, ATQR ATMR	248-4
Class G	480/600VAC	0-20/21-60	100	AG	248-5
Class H (Renewable)	250/600VAC	0-600	10	RF/RFS	248-7
Class H (Non-Renew)	250/600VAC	0-600	10	NRN, CRN/NRS, CRS	248-6
Class J	600VAC 300VDC 500VDC	0-600 0-30 0-600	200 100 100	AJT, HSJ, A4J A4J, HSJ(1-10) AJT, HSJ(15-600)	248-8
Class K-5	250/600VAC	0-600	50	OT, OTN/OTS	248-9
Class L	600VAC 500VDC	601-6000 601-3000	200 100	A4BQ, A4BY, A4BT A4BQ	248-10
Class RK1	250/600VAC 600VAC 250VDC 600VDC	0-600 70-600 0-600 0-600	200 200 100 100	A2D, A2K/A6D, A6K A2D A6D	248-12
Class RK5	250/600VAC 300/600VDC	0-600 0-30/35-400	200 20	TR/TRS TRS-RDC	248-12
Class T	300/600VAC 160/300VDC	0-1200/0-800 0-1200	200 50/100	A3T/A6T A3T/A6T	248-15
Glass/Electronic	32-350VAC	0-30	Up to 10	See Section MF	248-14
Midget	125/250VAC 500/600VAC	0-30 0-30	0.2-10 10,100	TRM, OTM, GFN ATQ, ATM, SBS	248-14
Cable Protector	250VAC 600VAC	1-500kcmil Cu or Al #2-1000kcmil Cu or Al	200 200	2CL CP, CPH	248-1
Capacitor	600-5500VAC	25-300	Up to 200	A100C-A550C	Other
Welder	600VAC	100-600	200	A4BX	Other
Photovoltaic				See Section MF	

FUSE CONSTRUCTION AND OPERATION

The typical fuse consists of an element which is surrounded by a filler and enclosed by the fuse body. The element is welded or soldered to the fuse contacts (blades or ferrules).

The element is a calibrated conductor. Its configuration, its mass, and the materials employed are selected to achieve the desired electrical and thermal characteristics. The element provides the current path through the fuse. It generates heat at a rate that is dependent upon its resistance and the load current.

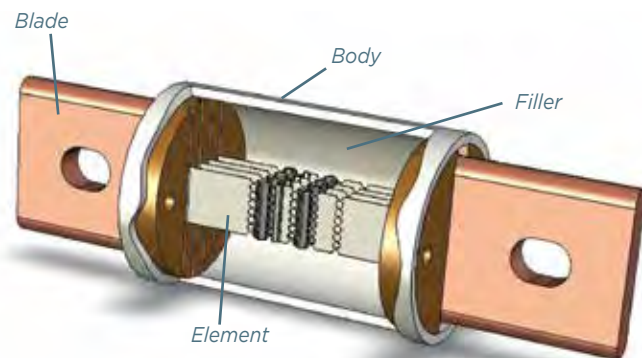

The heat generated by the element is absorbed by the filler and passed through the fuse body to the surrounding air. A filler such as quartz sand provides effective heat transfer and allows for the small element cross-section typical in modern fuses. The effective heat transfer allows the fuse to carry harmless overloads. The small element cross section melts quickly under short circuit conditions. The filler also aids fuse performance by absorbing arc energy when the fuse clears an overload or short circuit.

When a sustained overload occurs, the element will generate heat at a faster rate than the heat can be passed to the filler. If the overload persists, the element will reach its melting point and open. Increasing the applied current will heat the element faster and cause the fuse to open sooner. Thus fuses have an inverse time current characteristic, i.e. the greater the overcurrent the less time required for the fuse to open the circuit.

This characteristic is desirable because it parallels the characteristics of conductors, motors, transformers and other electrical apparatus. These components can carry low level overloads for relatively long times without damage. However, under high current conditions damage can occur quickly. Because of its inverse time current characteristic, a properly applied fuse can provide effective protection over a broad current range, from low level overloads to high level short circuits.

HOW TO READ A TIME-CURRENT CURVE

A time-current characteristic curve, for any specified fuse, is displayed as a continuous line representing the average melting time in seconds for a range of overcurrent conditions. The melting time is considered nominal unless noted otherwise. Several curves are traditionally shown on one sheet to represent a family of fuses. The family shown here is the Time Delay Class J AJT Amp-Trap 2000® fuse.

Information can be accessed from these curves in several ways:

- If a fuse has been selected, the designer can use the curve for that fuse to check its opening time versus a given overcurrent. Example: Using the 30 ampere fuse curve, what is the fuse opening time in seconds at a current of 160 amperes? At the bottom of the sheet (Current in Amperes) find 160 amperes (Pt. A) and follow that line straight up until it intersects the 30A curve (Pt. B). Then follow that line to the left edge (Time in Seconds) and read 10 seconds. (Pt. C). This tells us that the AJT30 will open in 10 seconds on a current of 160 amperes.
- Likewise, for the same fuse we might want to know what current will open the fuse in 0.1 second. On the vertical axis (Time in Seconds) find 0.1 second (Pt. D) and follow that line to the right until it intersects the 30A curve (Pt. E). Then follow that line straight down to the horizontal axis (Current in Amperes) and read 320 amperes (Pt. F). This shows that the AJT30 requires an overcurrent of 320 amperes to open in 0.1 second.
- The curves can be used in other ways by the designer. For example, if a family has been chosen (i.e. Time Delay Class J AJT) and an opening time of approximately 1 second is required at 3000 amperes, what fuse in the

family best meets this need? Find the 3000 ampere line on the horizontal axis (Pt. G) and follow it up to the 1 second line (Pt. H). The nearest curve to the right is the AJT400. If the point is not near a curve shown, other intermediate curves are available from the factory.

Sometimes the fuse family or type has not been chosen, so a design requirement can be presented to several family characteristic curves. One fuse type will emerge as a good choice. Voltage rating, interrupting rating, physical size, time delay, etc. are all considerations in the final choice.

AJT TIME DELAY / CLASS J

Melting Time -Current Data 1-600 Amperes, 600 Volts AC

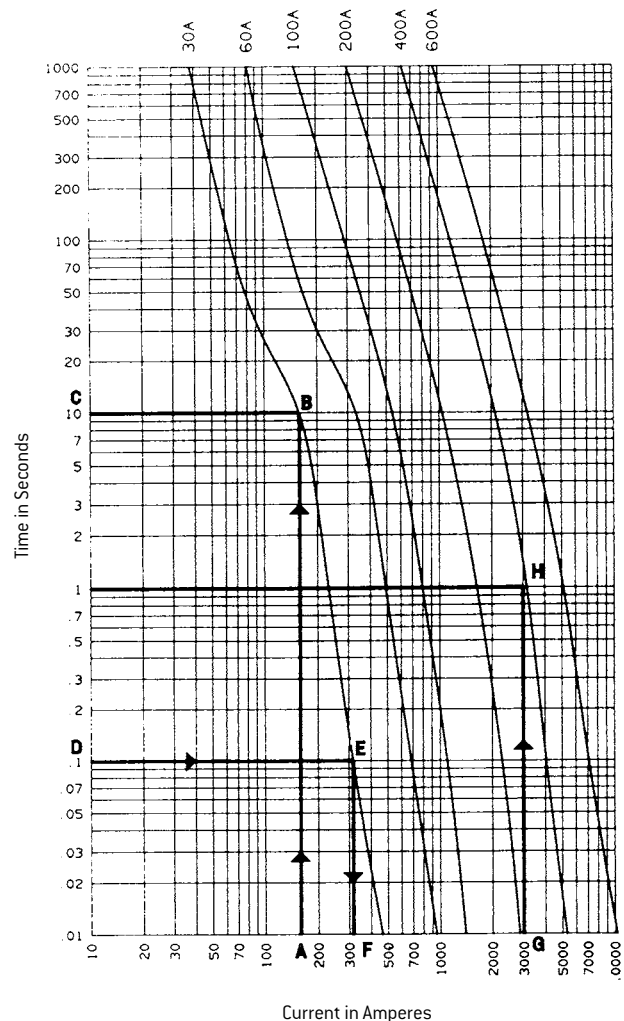

CODE REQUIREMENTS

The NEC or CEC requires that motor branch circuits be protected against overloads and short circuits. Overload protection may be provided by fuses, overload relays or motor thermal protectors. Short circuit protection may be provided by fuses or circuit breakers.

OVERLOAD PROTECTION

The NEC or CEC allows fuses to be used as the sole means of overload protection for motor branch circuits. This approach is often practical with small single phase motors. If the fuse is the sole means of protection, the fuse ampere rating must not exceed the values shown in Table 1.

Most integral horsepower 3 phase motors are controlled by a motor starter which includes an overload relay. Since the overload relay provides overload protection for the motor branch circuit, the fuses may be sized for short circuit protection.

SHORT CIRCUIT PROTECTION

The motor branch circuit fuses may be sized as large as shown in Table 2 when an overload relay or motor thermal protector is included in the branch circuit. Time delay fuse ratings may be increased to 225% and non-time delay fuse ratings to 400% (300% if over 600 amperes) if the ratings shown in Table 2 will not carry motor starting current.

Some manufacturers' motor starters may not be adequately protected by the maximum fuse sizing shown in Table 2. If this is the case, the starter manufacturer is required by UL 508 to label the starter with a maximum permissible fuse size. If so labeled, this maximum value is not to be exceeded.

Where the percentages shown in Table 2 do not correspond to standard fuse ratings the next larger fuse rating may be used. Standard fuse ratings in amperes:

15 20 25 30 35 40 45 50
60 70 80 90 100 110 125 150
175 200 225 250 300 350 400 450
500 600 700 800 1000 1200 1600 2000
2500 3000 4000 5000 6000

FUSE SELECTION GUIDELINES

What fuse type and ampere rating is best for a given application? The answer depends upon the application and objective to be met. Here are some suggestions.

WHICH FUSE CLASS?

UL Classes RK5, RK1, and J are the most popular. The Class RK5 (Tri-onic®) is the least expensive. The Class RK1 (Amp-Trap®) is used where a higher degree of current limitation is required for improved component protection or system coordination. The RK5 and RK1 are dimensionally interchangeable.

The Class J time delay fuse (AJT) provides advantages over the RK5 and RK1 fuses. Class J fuses provide a higher degree of current limitation than the RK's. This reduced fault current will reduce arc faults in cases of an arc flash incident.

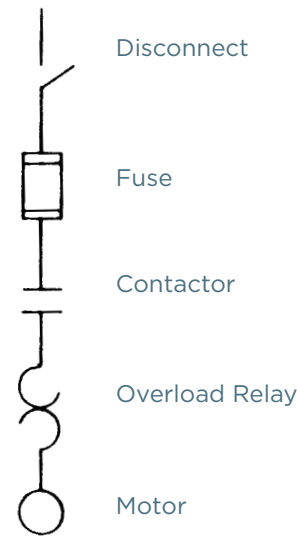

MOTOR BRANCH CIRCUIT

TABLE 1- MAXIMUM FUSE RATING FOR OVERLOAD PROTECTION

Motor Service Factor or Marked Temperature Rise	Fuse Rating as %* Motor Full Load
Service factor of 1.15 or greater	125
Marked temperature rise not Exceeding 40°C	125
All Others	115

* These percentages are not to be exceeded.

TABLE 2- MAXIMUM FUSE RATING FOR SHORT CIRCUIT PROTECTION

Type of Motor	Fuse Rating as %* Motor Full Load* Fuse Type	
	Non-Time Delay	Time Delay
All Single-phase AC motors	300	175
AC polyphase motors other than wound-rotor:		
Squirrel Cage		
Other than Design E	300	175
Design E	300	175
Synchronous	300	175
Wound rotor	150	150
Direct-current (constant voltage)	150	150

* The non-time delay ratings apply to all class CC fuses.

The Class J fuse is also about half the physical size of the RK5 and RK1 reducing panel space and saving money.

TIME DELAY VS. NON-TIME DELAY

Time delay fuses are the most useful fuses for motor branch circuit application. A time delay fuse can be sized closer to motor full load current, providing a degree of overload protection, better short circuit protection, and possible use of a smaller disconnect switch.

WHAT AMPERE RATING?

The selection of fuse ampere rating is a matter of experience and personal preference. Some prefer to size time delay fuses at 125% of motor full load amperes. This sizing will provide a degree of overload protection for motors with a service factor of 1.15. Sizing fuses at 125% of motor nameplate amperes in some applications may result in nuisance fuse openings. Time delay fuses sized at 125% may open at motor locked rotor current before some NEMA Class 20 overload relays operate. Nuisance fuse openings may result if Class RK1 or Class J fuses are sized at 125% of motor full load current. These fuses are more current limiting than the RK5 and have less short time current carrying capability.

Sizing time delay fuses between 125% and 150% of motor full load current provides advantages. The fuse will coordinate with NEMA Class 20 overload relays. Nuisance fuse opening will virtually be eliminated and effective short circuit protection will be maintained.

For newer, premium efficiency motors, sizing fuses between 125% and 150% may not be sufficient enough to handle the expected higher motor locked-rotor currents. For suggestions on sizing fuses for these situations, refer to the high-efficiency sizing summary at the end of this section.

PROTECTING IEC STYLE MOTOR STARTERS

The new IEC European style motor starters and contactors are popular but they present different problems in protection. These devices represent substantial savings in space and cost but they have a lower withstand capability than their NEMA counterparts.

In order to achieve the same level of protection for IEC style devices that we expect for NEMA devices, the AJT Class J Time Delay fuse is the best choice, sized at 1.25 to 1.50 times motor full load amperes. Also, the AJT has the advantage of being half the size of RK5 and RK1 fuses and thereby fits the trim IEC package.

SINGLE PHASE MOTOR FUSE SELECTION UL CLASSES RK1, RK5, J & CC

Motor Characteristics*		Fuse Classes and Ampere Ratings					
Motor HP	Full Load Current	Recommended Rating	Class CC (ATDR)		Class J (AJT) and RK5/1 (TR/A2D)		
			Max. Rating per NEC 430.52(C)(1), Exception No. 1†	Max. Rating per NEC 430.52(C)(1), Exception No. 2††	Recommended Rating	Max. Rating per NEC 430.52(C)(1), Exception No. 1†	Max. Rating per NEC 430.52(C)(1), Exception No. 2††
Single Phase, 115 V							
1/6	4.4	15	15	15	7	10	10
1/4	5.8	17-1/2	20	20	9	15	15
1/3	7.2	25	25	25	12	15	15
1/2	9.8	30	30	30	15	20	20
3/4	13.8	-	-	-	20	25	30
1	16	-	-	-	25	30	35
1-1/2	20	-	-	-	30	35	45
2	24	-	-	-	35	45	50
3	34	-	-	-	60	60	70
5	56	-	-	-	80	100	125
7-1/2	80	-	-	-	125	150	175
10	100	-	-	-	150	175	225
Single Phase, 230 V							
1/6	2.2	7	10	10	3-1/2	6	6
1/4	2.9	9	10	10	4-1/2	6	6
1/3	3.6	12	15	15	5-6/10	10	10
1/2	4.9	15	15	15	7	10	10
3/4	6.9	20	25	25	12	15	15
1	8	25	25	30	12	15	17-1/2
1-1/2	10	30	30	30	15	20	20
2	12	-	-	-	20	25	25
3	17	-	-	-	25	30	35
5	28	-	-	-	40	50	60
7-1/2	40	-	-	-	60	70	90
10	50	-	-	-	80	90	110

* Values obtained from NEC 2017 Table 430.250. Fuse ampere ratings based on percentages of full-load current values from this table.

† Sizing based on 175% of motor FLA for Time-Delay Class J/R fuses and 300% of motor FLA for Time-Delay Class CC fuses. Values rounded up to the next standard rating.

†† Sizing based on 225% of motor FLA for Time-Delay Class J/R fuses and 400% of motor FLA for Time-Delay Class CC fuses. Fuse ratings cannot exceed these values.

THREE PHASE MOTOR FUSE SELECTION UL CLASSES RK5, RK1, J & CC

Motor Characteristics*		Fuse Classes and Ampere Ratings					
Motor HP	Full Load Current	Recommended Rating	Class CC (ATDR)		Class J (AJT) and RK5/1 (TR/A2D)		
			Max. Rating per NEC 430.52(C)(1), Exception No. 1†	Max. Rating per NEC 430.52(C)(1), Exception No. 2††	Recommended Rating	Max. Rating per NEC 430.52(C)(1), Exception No. 1†	Max. Rating per NEC 430.52(C)(1), Exception No. 2††
Three Phase, 208 V							
0.5	2.4	8	10	10	3-1/2	6	6
0.75	3.5	10	15	15	5	10	10
1	4.6	15	15	15	7	10	10
1.5	6.6	20	20	25	10	15	15
2	7.5	25	25	30	12	15	15
3	10.6				15	20	20
5	16.7				25	30	35
7.5	24.2				35	45	50
10	30.8				45	60	60
15	46.2				70	90	100
20	59.4				90	110	125
25	74.8				110	150	150
30	88				150	175	175
40	114				175	200	250
50	143				225	300	300
60	169				250	300	350
75	211				350	400	450
100	273				400	500	600
125	343				500	600	-
150	396				600	-	-
Three Phase, 230 V							
0.5	2.2	7	10	10	3-1/2	6	6
0.75	3.2	10	10	12	5	6	7
1	4.2	12	15	15	6-1/4	10	10
1.5	6	17-1/2	20	20	9	15	15
2	6.8	20	25	25	10	15	15
3	9.6	30	30	30	15	20	20
5	15.2				25	30	30
7.5	22				35	40	45
10	28				40	50	60
15	42				70	80	90
20	54				80	100	110
25	68				110	125	150
30	80				125	150	175
40	104				150	200	225
50	130				200	250	250
60	154				225	300	300
75	192				300	350	400
100	248				350	450	500
125	312				450	600	600
150	360				500	600	-

* Values obtained from NEC 2017 Table 430.250. Fuse ampere ratings based on percentages of full-load current values from this table.

† Sizing based on 175% of motor FLA for Time-Delay Class J/R fuses and 300% of motor FLA for Time-Delay Class CC fuses. Values rounded up to the next standard rating.

†† Sizing based on 225% of motor FLA for Time-Delay Class J/R fuses and 400% of motor FLA for Time-Delay Class CC fuses. Fuse ratings cannot exceed these values.

THREE PHASE MOTOR FUSE SELECTION
UL CLASSES RK5, RK1, J, CC

Motor Characteristics*		Fuse Classes and Ampere Ratings					
Motor HP	Full Load Current	Recommended Rating	Class CC (ATDR)		Class J (AJT) and RK5/1 (TRS/A6D)		
			Max. Rating per NEC 430.52(C)(1), Exception No. 1†	Max. Rating per NEC 430.52(C)(1), Exception No. 2††	Recommended Rating	Max. Rating per NEC 430.52(C)(1), Exception No. 1†	Max. Rating per NEC 430.52(C)(1), Exception No. 2††
Three Phase, 460 V							
0.5	1.1	3-1/2	6	6	1-6/10	3	3
0.75	1.6	5	6	6-1/4	2-1/2	3	3-1/2
1	2.1	6-1/4	10	10	3-2/10	6	6
1.5	3	9	10	12	4-1/2	6	6-1/4
2	3.4	10	15	15	5	6	7
3	4.8	15	15	15	7	10	10
5	7.6	25	25	30	12	15	15
7.5	11				17-1/2	20	20
10	14				20	25	30
15	21				35	40	45
20	27				40	50	60
25	34				50	60	70
30	40				60	70	90
40	52				80	100	110
50	65				100	125	125
60	77				125	150	150
75	96				150	175	200
100	124				200	225	250
125	156				225	300	350
150	180				250	350	400
200	240				350	450	500
250	302				450	600	600
300	361				600	-	-
Three Phase, 575V							
0.5	0.9	2-8/10	3	3-1/2	1-1/2	3	3
0.75	1.3	4	6	6	2	3	3
1	1.7	5-6/10	6	6-1/4	2-8/10	3	3-1/2
1.5	2.4	8	10	10	3-1/2	6	6
2	2.7	8	10	10	4	6	6
3	3.9	12	15	15	6	10	10
5	6.1	17-1/2	20	20	10	15	15
7.5	9	30	30	30	15	20	20
10	11				17-1/2	20	20
15	17				25	30	35
20	22				35	40	45
25	27				40	50	60
30	32				50	60	70
40	41				60	80	90
50	52				80	100	110
60	62				90	110	125
75	77				125	150	150
100	99				150	175	200
125	125				200	225	250
150	144				225	300	300
200	192				300	350	400
250	242				350	450	500
300	289				450	600	600

* Values obtained from NEC 2017 Table 430.250. Fuse ampere ratings based on percentages of full-load current values from this table.

† Sizing based on 175% of motor FLA for Time-Delay Class J/R fuses and 300% of motor FLA for Time-Delay Class CC fuses. Values rounded up to the next standard rating.

†† Sizing based on 225% of motor FLA for Time-Delay Class J/R fuses and 400% of motor FLA for Time-Delay Class CC fuses. Fuse ratings cannot exceed these values.



FUSE SIZING CONSIDERATIONS FOR HIGHER EFFICIENCY MOTORS

When selecting the proper fuse for short circuit protection in motor starting applications, it is important to not only ensure that the fuse will not nuisance open during motor start up times, but also that the fuse will coordinate as required with overload relays. When sizing fuses between 125% and 150% of the motor nameplate current, several advantages, including ease of coordination with an overload device, a smaller disconnect, and increased short circuit protection from a lower fuse rating, can be achieved. However, if sizing at this level prevents the motor from starting, it may then be necessary to increase the fuse ampere rating and it then becomes important to know the NEC sizing limitations.

As of June 1, 2016, the US Department of Energy has mandated that newly manufactured electric motors will need to meet NEMA Premium® efficiency standards. As motor efficiencies increase, motor locked rotor currents can also be expected to increase. In addition to this, with across-the-line starting applications, it is critical to understand not only the locked rotor current, but also the starting time that can be expected.

With previous efficiencies, typically motor locked rotor currents between 300% and 600% of motor nameplate currents were common. However, with the new efficiency standards, locked rotor currents for NEMA Design B, C, and D motors can reach between 600% and 700% of nameplate currents and are restricted to maximum levels per the NEMA design standards. With NEMA Design E motors, these levels can be expected to be as high as 1000% of the rated current. Design A motors have no standardized maximums for locked rotor currents, but can be very high depending on the motor kVA code value. Special attention should be paid to the motor nameplate values when sizing motor protection fuses.

For Premium Efficiency motors, sizing fuses between 125% and 150% of the rated current may not be sufficient to allow the motor to start due to the potential magnitude of locked rotor currents. In addition to this, if the expected start time of the motor is over 5 seconds, this may be too long for this size fuse to handle without opening. Section 430.52(C)(1), Exception 1 in the NEC allows for Time-Delay Class R and J fuses to be sized at 175% of the rated motor current up to the next standard fuse size.

If sizing at 175% still does not allow for the motor to start, section 430.52(C)(1), Exception 2 in the NEC permits an absolute maximum fuse size of 225% of the motor rated current. In these cases, depending on the value determined from these multiplication factors, fuse sizes between Exceptions 1 and 2 may be exactly the same. Where Exception 1 permits rounding up to the next standard size, fuses sized to Exception 2 may not exceed the mentioned 225% value in any way.

For Time-Delay Class CC fuses, similar exceptions in the NEC also apply. Section 430.52(C)(1), Exception 1 allows for a fuse size of 300% up to the next standard rating. Section 430.52(C)(1), Exception 2 permits a fuse size not exceeding 400% of the motor rated current, should 300% sizing still not allow the motor to start.

NEC 430.52 Fuse Sizing Limits		
NEC Sections	Time-Delay Class R/J Fuse	Time-Delay Class CC Fuse
NEC 430.52(C)(1), Exception 1	175%*	300%*
NEC 430.52(C)(1), Exception 2	225%**	400%**

* Values may be rounded up to next standard fuse ampere rating.

** Permitted when Exception 1 ratings are not sufficient for motor starting current. Ratings may not exceed these limits.

This section summarizes transformer overcurrent protection as required by the National Electrical Code (NEC) and Canadian Electric Code.

TRANSFORMERS - PRIMARY 1000 VOLTS OR LESS

If secondary fuse protection is not provided, primary fuses are to be selected according to Table 1. If both primary and secondary fuses are used, they are to be selected according to Table 2.

Table 1 - Primary Fuse Only

Transformer Primary Amperes	Maximum Primary Fuse % Rating
9 or more	125*
2 to less than 9	167
less than 2	300

Table 2 - Primary & Secondary Fuses

Transformer Secondary Amperes	Maximum Primary Fuse % Rating	
	Primary Fuse	Secondary Fuse
9 or more	250	125*
less than 9	250	167

* If 125% does not correspond to a standard ampere rating, the next higher standard rating shall be permitted.

TRANSFORMER MAGNETIZING INRUSH CURRENTS

When voltage is switched on to energize a transformer, the transformer core normally saturates. This results in a large inrush current which is greatest during the first half cycle (approximately 0.01 second) and becomes progressively less severe over the next several cycles (approximately 1 second) until the transformer reaches its normal magnetizing current.

To accommodate this inrush current, fuses are often selected which have time-current withstand values of at least 12 times transformer primary rated current for .1 second and 25 times for .01 second. Recommended primary fuses for popular, low voltage 3-phase transformers are shown on the next page. Some small dry-type transformers may have substantially greater inrush currents. For these applications, the fuse may have to be selected to withstand 45 times transformer primary rated current for .01 second.

SECONDARY FUSES

Selecting fuses for the secondary is simple once rated secondary current is known. Fuses are sized at 125% of secondary FLA or the next higher rating; or at maximum 167% of secondary FLA, see Table 2 for rules. The preferred sizing is 125% of rated secondary current I_{sec} or next higher fuse rating. To determine I_{sec} , first determine transformer rating (VA or kVA), secondary voltage (V_{sec}) and use formulas below.

- Single Phase : $I_{sec} = \frac{\text{Transformer VA}}{V_{sec}}$
or $\frac{\text{Transformer kVA} \times 1000}{V_{sec}}$
- Three Phase : $I_{sec} = \frac{\text{Transformer VA}}{1.73 \times V_{sec}}$
or $\frac{\text{Transformer kVA} \times 1000}{1.73 \times V_{sec}}$

When I_{sec} is determined, multiply it by 1.25 and choose that fuse rating or next higher rating.
[$I_{sec} \times 1.25 = \text{Fuse Rating}$]

Fusing for Three Phase Transformer Primaries without Secondary Protection

Transformer kVA	240V Primary		480V Primary		600V Primary	
	FLA	TR-R Fuse Rating	FLA	TR-R Fuse Rating	FLA	TR-R Fuse Rating
3	7.2	9	3.6	4-1/2	2.9	4
5	12	15	6	8	4.8	6
7.5	18	25	9	12	7.2	9
9	22	30	11	15	9	12
15	36	45	18	25	14	20
30	72	90	36	45	29	35
45	108	150	54	70	43	60
75	180	225	90	125	72	90
100	241	300	120	150	96	125
112.5	271	350	135	175	108	150
150	361	450	180	225	144	200
225	541	600	371	350	217	300
300	722	-	361	450	289	350
500	1203	-	601	-	481	600

* Where fuse sizes do not correspond to a standard ampere rating, the next higher standard rating shall be permitted.

Fusing for Three Phase Transformers - Primary and Secondary Protection

Transformer (kVA)	Primary Fuse Series and Ratings					Secondary Series and Ratings			
	240 V Primary					120 V Secondary		208 V Secondary	
	FLA	AJT/A2D-R	A4BT	A4BY	A4BQ	FLA	Fuse Rating	FLA	Fuse Rating
3	7.2	15	-	-	-	14	20	8	12
5	12	25	-	-	-	24	30	14	17-1/2
7.5	18	40	-	-	-	36	45	21	30
9	22	45	-	-	-	43	60	25	35
15	36	60	-	-	-	72	100	42	60
30	72	150	-	-	-	145	200	83	110
45	108	225	-	-	-	217	300	125	175
75	180	400	-	-	-	361	450	208	300
100	241	450	-	-	-	482	600	278	350
112.5	271	500	-	-	-	542	700	313	400
150	361	600	-	-	-	723	900	417	600
225	541	-	800	900	1200	1084	1350	625	800
300	722	-	1200	1200	1600	1445	1800	834	1200
500	1203	-	1800	2000	2500	2408	2500	1390	1600

Transformer (kVA)	Primary Fuse Series and Ratings					Secondary Fuse Ratings					
	480 V Primary					120 V Secondary		208 V Secondary		240 V Secondary	
	FLA	AJT/A6D-R	A4BT	A4BY	A4BQ	FLA	Fuse Rating	FLA	Fuse Rating	FLA	Fuse Rating
3	3.6	6	-	-	-	14	20	8	12	7	9
5	6	12	-	-	-	24	30	14	17-1/2	12	15
7.5	9	15	-	-	-	36	45	21	30	18	25
9	11	25	-	-	-	43	60	25	35	22	30
15	18	35	-	-	-	72	100	42	60	36	45
30	36	60	-	-	-	145	200	83	110	72	100
45	54	100	-	-	-	217	300	125	175	108	150
75	90	175	-	-	-	361	450	208	300	181	250
100	120	225	-	-	-	482	600	278	350	241	350
112.5	135	300	-	-	-	542	700	313	400	271	350
150	180	400	-	-	-	723	900	417	600	361	500
225	371	500	-	-	-	1084	1350	625	800	542	700
300	361	600	-	-	-	1445	1800	834	1200	723	1000
500	601	-	1000	1000	1200	2408	2500	1390	1600	1204	1600
750	902	-	1400	1600	2000	3613	4000	2084	2500	1806	2000
1000	1203	-	1800	2000	2500	4817	5000	2779	3000	2408	2500

Transformer (kVA)	Primary Fuse Series and Ratings					Secondary Fuse Ratings					
	600 V Primary					120 V Secondary		208 V Secondary		240 V Secondary	
	FLA	AJT/A6D-R	A4BT	A4BY	A4BQ	FLA	Fuse Rating	FLA	Fuse Rating	FLA	Fuse Rating
3	2.9	5	-	-	-	14	20	8	12	7	9
5	4.8	10	-	-	-	24	30	14	17-1/2	12	15
7.5	7.2	15	-	-	-	36	45	21	30	18	25
9	9	17-1/2	-	-	-	43	60	25	35	22	30
15	14	25	-	-	-	72	100	42	60	36	45
30	29	45	-	-	-	145	200	83	110	72	100
45	43	80	-	-	-	217	300	125	175	108	150
75	72	150	-	-	-	361	450	208	300	181	250
100	96	200	-	-	-	482	600	278	350	241	350
112.5	108	225	-	-	-	542	700	313	400	271	350
150	144	300	-	-	-	723	900	417	600	361	500
225	217	450	-	-	-	1084	1350	625	800	542	700
300	289	500	-	-	-	1445	1800	834	1200	723	1000
500	481	-	700	900	1000	2408	2500	1390	1600	1204	1600
750	722	-	1200	1400	1600	3613	4000	2084	2500	1806	2000
1000	962	-	1600	1800	2000	4817	5000	2779	3000	2408	2500

Control circuit transformers used as part of a motor control circuit are to be protected as outlined in Tables 1 & 2 with one important exception. Primary fuses may be sized up to 500% of transformer rated primary current if the rated primary current is less than 2 amperes.

When a control circuit transformer is energized, the typical magnetizing inrush will be 25-40 times rated primary full load current (FLA) for the first 1/2 cycle and dissipates to rated current in a few cycles. Fuses must be sized so they do not open during

this inrush. We recommend that fuses be selected to withstand 40 x FLA for .01 sec. and to stay within the NEC guidelines specified above.

For example: 300VA Transformer, 600V primary.

$$I_{pri} = \frac{\text{Transformer VA}}{\text{Primary V}} = \frac{300}{600} = 1/2A = \text{FLA}$$

The fuse time-current curve must lie to the right of the point 40 x (1/2A) = 20A @ .01 sec.

Secondary fuses are still sized at 125% of the secondary FLA.

Recommended Primary Fuses for Single Phase Control Transformers

Trans VA	600 Volt Primary						480 Volt Primary					
	FLA	ATQR	ATMR	A6D-R+	AJT+	TRS-R	FLA	ATQR	ATMR	A6D-R+	AJT+	TRS-R
25	.042	1/10	2/10	2/10	-	1/10	.052	1/10	1/4	1/4	-	1/10
50	.083	1/4	3/10*	4/10	-	2/10	.104	1/4	1/2*	1/2	-	2/10
75	.125	1/4	1/2*	6/10	-	2/10	.156	3/10	3/4*	6/10	-	2/10
100	.167	3/10	3/4*	8/10	-	3/10	.208	4/10	1	1	1	3/10
130	.22	4/10	1	1	1	4/10	.27	1/2	1	1	1-1/2	4/10
150	.25	1/2	1*	1-1/4	1	4/10	.313	1/2	1-1/2	1-4/10	1-1/2	4/10
200	.33	1/2	1-1/2	1-6/10	1-1/2	6/10	.417	6/10	2	2	2	6/10
250	.42	6/10	2	2	2	6/10	.52	8/10	2	2-1/2	2-1/2	6/10
300	.50	1	2	2-1/2	2	8/10	.62	1-1/2	3	3	3	8/10
350	.583	1-1/4	2	2-8/10	2	1	.73	1-1/2	3-1/2	3-1/2	3-1/2	1
500	.833	1-1/2	4	4	4	1-1/4	1.04	2	5	4	4	1-4/10
750	1.25	2-1/2	6	4	4	1-6/10	1.56	3*	7	5	5	2
1000	1.67	3	8	5	5	2-1/4	2.08	4+	-	5+	5+	3
1500	2.5	5+	-	6+	6+	4	3.125	7+	-	6-1/4+	6-1/4+	4
2000	3.33	8+	-	8+	8+	5	4.17	10+	-	7+	7+	5
3000	5.00	12+	-	12+	12+*	8	6.25	15+*	-	15+*	15+	8
5000	8.33	20+*	-	20+*	20+**	12+	10.4	-	-	25+*	25+*	15+
7500	12.5	30+*	-	30+*	30+**	17-1/2+	15.6	-	-	35+**	35+**	20+
10000	16.7	-	-	40+*	40+**	25+	20.8	-	-	50+**	50+**	30+
		240 Volt Primary					120 Volt Primary					
25	.104	2/10	1/2	1/2	-	2/10	.21	4/10	1	1	1	3/10
50	.21	4/10	1	1	1	3/10	.42	6/10	2	2	2	6/10
75	.31	1/2	1-1/2	1-4/10	1-1/2	4/10	.6	1	3	3	3	8/10
100	.42	6/10	2	2	2	6/10	.83	1-1/2	4	4	4	1
130	.54	1	2-1/2	2-1/2	2-1/2	8/10	1.08	2-1/2	5	4	4	1-6/10
150	.625	1	3	3	3	8/10	1.25	2-1/2	6	4	4	1-6/10
200	.83	1-1/2	4	3-1/2	3-1/2	1	1.67	3*	8	5	5	2-1/4
250	1.04	2	5	4	4	1-4/10	2.08	4+	-	5+	5+	2-8/10
300	1.25	2-1/2	6	4	4	1-6/10	2.5	5+	-	6+	6+	3-2/10
350	1.46	3*	7	5	5	2	2.92	7+	-	6+	6+	4
500	2.08	4+	-	5+	5+	2-8/10	4.17	10+	-	10+	6	5-6/10
750	3.13	7+	-	6-1/4+	6-1/4+	4	6.25	15+*	-	15+**	15+	8
1000	4.2	10+	-	7	7	5-6/10	8.33	20+*	-	20+**	20+*	12+
1500	6.25	15+	-	15+	15+	8	12.5	30+*	-	30+	30+	15
2000	8.3	20+*	-	20+**	20+**	12	16.7	-	-	40+**	40+	25+
3000	12.5	30+*	-	30+**	30+**	15	25	-	-	60+**	60+*	35+
5000	20.8	-	-	50+**	50+*	25	41.7	-	-	100+**	100+**	60+
7500	31.3	-	-	70+**	70+**	40+	62.5	-	-	150+**	150+**	90+
10000	41.7	-	-	100+**	100+**	60+	83.3	-	-	200+**	200+**	125+

The above fuses will withstand 40 x FLA for .01 second except where noted. + Secondary fusing required.

* Fuse will withstand 30 x FLA for .01 second.
** Fuse will withstand 35 x FLA for .01 second.



3 Phase 2400 Volt Typical Primary Fuse Sizing Chart										
Trans- former Rating kVA ¹	Full Load Amperes	2" Ferrule mounting			3" Ferrule mounting (single and double)			Bolt on		Clip Lock
		9F60 EJ "C"	9F60 EJO "C"	A055F	9F60 EJ "D"	9F60 EJO "D"	A055F	A055B	A055C	
9	2.2	9F60CCB005 *	9F60DJB005	A055F1CORO-5E	-	-	-	-	-	
15	3.6	9F60CCB010 *	9F60DJB010	A055F1CORO-7E	-	-	-	-	-	
30	7.2	9F60CCB020 *	9F60DJB020	A055F1CORO-10E	-	-	A055F1DORO-10E	A055B1DARO-10E	A055C1DORO-10E	
45	11	9F60CCB025 *	9F60DJB025	A055F1CORO-15E	-	-	A055F1DORO-15E	A055B1DARO-15E	A055C1DORO-15E	
75	18	-	-	A055F1CORO-25E	9F60ECB030	9F60FJB030	A055F1DORO-25E	A055B1DARO-25E	A055C1DORO-25E	
112.5	27	-	-	A055F1CORO-40E	9F60ECB050	9F60FJB050	A055F1DORO-40E	A055B1DARO-40E	A055C1DORO-40E	
150	36	-	-	A055F1CORO-50E	9F60ECB065	9F60FJB065	A055F1DORO-50E	A055B1DARO-50E	A055C1DORO-50E	
225	54	-	-	-	9F60ECB100	9F60FJB100	A055F1DORO-80E	A055B1DARO-80E	A055C1DORO-80E	
300	72	-	-	-	9F60GCB125	9F60HJB125	A055F1DORO-100E	A055B1DARO-100E	A055C1DORO-100E	
500	120	-	-	-	9F60GCB200	9F60HJB200	A055F1DORO-200E	A055B1DARO-200E	A055C1DORO-200E	
750	181	-	-	-	-	-	A055F2DORO-250E	A055B2DARO-250E	A055C1DORO-250E	
1000	241	-	-	-	-	-	A055F2DORO-400E	A055B2DARO-400E	A055C1DORO-400E	
1500	361	-	-	-	-	-	-	A055B2DORO-500E	A055C2DORO-500E	
2000	482	-	-	-	-	-	-	A055B2DORO-600E	A055C2DORO-600E	

Fuses will carry transformer magnetizing inrush current of 25 times full load amperes for .01 second and 12 times full load current for .1 second
EJO fuses can be used outdoors without an enclosure ¹ the self cooled rating of the transformer * use CEB in place of CCB for 9" clip center fuses

3 Phase 4160 Volt Typical Primary Fuse Sizing Chart											
Trans- former Rating kVA ¹	Full Load Amp- eres	2" Ferrule mounting				3" Ferrule mounting (single and double)			Bolt on		Clip Lock
		9F60 EJ "C"	9F60 EJO "C"	9F62 EJO "C"	A055F	9F60 EJO "D"	9F62 EJO "D"	A055F	9F62 EJO "DDDD"	A055B	A055C
9	1.3	9F60CED005	9F60DJD005	-	A055F1CORO-5E	-	-	-	-	-	-
15	2.1	9F60CED007	9F60DJD007	-	A055F1CORO-5E	-	-	-	-	-	-
30	4.2	9F60CED015	9F60DJD015	-	A055F1CORO-7E	-	-	A055F1DORO-10E	-	A055B1DARO-10E	A055C1DORO-10E
45	6.3	9F60CED015	9F60DJD015	-	A055F1CORO-10E	-	-	A055F1DORO-10E	-	A055B1DARO-10E	A055C1DORO-10E
75	10	9F60CED025	9F60DJD025	9F62HCB025	A055F1CORO-15E	-	-	A055F1DORO-15E	-	A055B1DARO-15E	A055C1DORO-15E
112.5	16	-	-	9F62HCB030	A055F1CORO-20E	9F60FJD040	-	A055F1DORO-20E	-	A055B1DARO-20E	A055C1DORO-20E
150	21	-	-	9F62HCB040	A055F1CORO-30E	9F60FJD040	-	A055F1DORO-30E	-	A055B1DARO-30E	A055C1DORO-30E
225	31	-	-	9F62HCB050	A055F1CORO-40E	9F60FJD065	-	A055F1DORO-40E	-	A055B1DARO-40E	A055C1DORO-40E
300	42	-	-	-	A055F1CORO-65E	9F60FJD080	9F62DCB080	A055F1DORO-65E	-	A055B1DARO-65E	A055C1DORO-65E
500	69	-	-	-	-	9F60FJD100	9F62DCB100	A055F1DORO-100E	-	A055B1DARO-100E	A055C1DORO-100E
750	104	-	-	-	-	9F60HJD150	9F62DCB150	A055F1DORO-150E	-	A055B1DARO-150E	A055C1DORO-150E
1000	139	-	-	-	-	9F60HJD200	9F62DCB200	A055F1DORO-200E	-	A055B1DARO-200E	A055C1DORO-200E
1500	208	-	-	-	-	-	9F62FCB300	A055F2DORO-300E	-	A055B2DARO-300E	A055C1DORO-300E
2000	278	-	-	-	-	-	9F62FCB350	A055F2DORO-400E	-	A055B2DARO-400E	A055C1DORO-400E
2500	347	-	-	-	-	-	-	-	9F62KCB500	A055B2DORO-500E	A055C2DORO-500E
3000	417	-	-	-	-	-	-	-	9F62KCB600	A055B2DORO-600E	A055C2DORO-600E
3750	520	-	-	-	-	-	-	-	9F62KCB700	A055B3DORO-750E	-
4000	556	-	-	-	-	-	-	-	9F62KCB700	A055B3DORO-750E	-
4500	625	-	-	-	-	-	-	-	9F62KCB800	A055B3DORO-900E	-
5000	695	-	-	-	-	-	-	-	9F62KCB900	A055B3DORO-900E	-

Fuses will carry transformer magnetizing inrush current of 25 times full load amperes for .01 second and 12 times full load current for .1 second
EJO fuses can be used outdoors without an enclosure ¹ the self cooled rating of the transformer

EXAMPLES

1. A new installation has a 300kVA transformer with 4160V primary. It is not fully loaded. What is the typical primary fuse recommended?

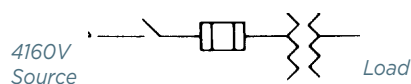

A 65 rating (Mersen A055F1DORO-65E or equivalent) is correct. Lower ratings may open when transformer is energized.

2. What is the normal fuse size recommended for a 1500kVA transformer with 12,470V primary?

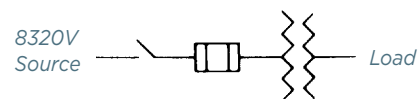

For this application use a 100E rating A155F2DORO-100E or equivalent which will allow normal overload operations of transformer up to 133% of rating.

3 Phase 4800 Volt Typical Primary Fuse Sizing Chart											
Transformer Rating kVA ¹	Full Load Amperes	2" Ferrule mounting				3" Ferrule mounting (single and double)			Bolt on		Clip Lock
		9F60 EJ "C"	9F60 EJO "C"	9F62 EJO "C"	A055F	9F60 EJO "D"	9F62 EJO "D"	A055F	9F62 EJO "DDDD"	A055B	A055C
9	1.1	9F60CED005	9F60DJ005	-	-	-	-	-	-	-	-
15	1.8	9F60CED005	9F60DJ005	-	A055F1C0R0-5E	-	-	-	-	-	-
30	3.6	9F60CED010	9F60DJ010	-	A055F1C0R0-7E	-	-	-	-	-	-
45	5.4	9F60CED015	9F60DJ015	-	A055F1C0R0-10E	-	-	A055F1D0R0-10E	-	A055B1DAR0-10E	A055C1D0R0-10E
75	9.0	9F60CED020	9F60DJ020	9F62HCB025	A055F1C0R0-15E	-	-	A055F1D0R0-15E	-	A055B1DAR0-15E	A055C1D0R0-15E
112.5	14	9F60CED030	9F60DJ030	9F62HCB030	A055F1C0R0-20E	-	-	A055F1D0R0-20E	-	A055B1DAR0-20E	A055C1D0R0-20E
150	18	-	-	9F62HCB040	A055F1C0R0-25E	9F60FJD040	-	A055F1D0R0-25E	-	A055B1DAR0-25E	A055C1D0R0-25E
225	27	-	-	9F62HCB050	A055F1C0R0-40E	9F60FJD065	-	A055F1D0R0-40E	-	A055B1DAR0-40E	A055C1D0R0-40E
300	36	-	-	9F62HCB065	A055F1C0R0-50E	9F60FJD065	-	A055F1D0R0-50E	-	A055B1DAR0-50E	A055C1D0R0-50E
500	60	-	-	-	-	9F60FJD100	9F62DCB080	A055F1D0R0-80E	-	A055B1DAR0-80E	A055C1D0R0-80E
750	90	-	-	-	-	9F60HJD125	9F62DCB125	A055F1D0R0-125E	-	A055B1DAR0-125E	A055C1D0R0-125E
1000	120	-	-	-	-	9F60HJD150	9F62DCB150	A055F1D0R0-200E	-	A055B1DAR0-200E	A055C1D0R0-200E
1500	181	-	-	-	-	-	9F62FCB250	A055F2D0R0-250E	-	A055B2DAR0-250E	A055C1D0R0-250E
2000	241	-	-	-	-	-	9F62FCB350	A055F2D0R0-300E	-	A055B2DAR0-400E	A055C1D0R0-400E
2500	301	-	-	-	-	-	9F62FCB400	A055F2D0R0-400E	-	A055B2DAR0-400E	A055C1D0R0-400E
3000	361	-	-	-	-	-	-	-	9F62KCB500	A055B2D0R0-500E	A055C2D0R0-500E
3750	421	-	-	-	-	-	-	-	9F62KCB600	A055B2D0R0-600E	A055C2D0R0-600E
4000	482	-	-	-	-	-	-	-	9F62KCB700	A055B2D0R0-600E	A055C2D0R0-600E
4500	542	-	-	-	-	-	-	-	9F62KCB700	A055B3D0R0-750E	-
5000	602	-	-	-	-	-	-	-	9F62KCB800	A055B3D0R0-900E	-
5500	662	-	-	-	-	-	-	-	9F62KCB900	A055B3D0R0-900E	-
6000	723	-	-	-	-	-	-	-	9F62KCB900	A055B3D0R0-900E	-

Fuses will carry transformer magnetizing inrush current of 25 times full load amperes for .01 second and 12 times full load current for .1 second
 EJO fuses can be used outdoors without an enclosure ¹ the self cooled rating of the transformer

3 Phase 6900 Volt Typical Primary Fuse Sizing Chart							
Transformer Rating kVA ¹	Full Load Amperes	2" Ferrule mounting		3" Ferrule mounting (single and double)			Bolt on
		9F60 EJO "C"	9F62 EJO "C"	9F60 EJO "D"	9F62 EJO "D"	A825X	A072B
9	0.75	9F60DJE003	-	-	-	-	-
15	1.3	9F60DJE005	-	-	-	-	-
30	2.5	9F60DJE010	-	-	-	-	-
45	3.8	9F60DJE010	-	-	-	-	-
75	6.3	-	9H62HCC020	9F60FJE020	-	A825X10-1	-
112.5	9.4	-	9H62HCC020	9F60FJE025	-	A825X15-1	-
150	13	-	9H62HCC025	9F60FJE040	-	A825X20-1	-
225	19	-	9H62HCC040	9F60FJE050	-	A825X25-1	-
300	25	-	9H62HCC040	9F60FJE065	-	A825X40-1	-
500	42	-	-	9F60FJE100	9F62DCC065	A825X65-1	-
750	63	-	-	9F60HJE125	9F62DCC080	A825X80-1	-
1000	84	-	-	9F60HJE150	9F62DCC150	A825X125-1	-
1500	126	-	-	-	9F62FCC200	A825X200-1	-
2000	168	-	-	-	9F62FCC250	-	A072B2D0R0-250E
2500	209	-	-	-	-	-	A072B2D0R0-300E
3000	251	-	-	-	-	-	A072B2D0R0-350E
3500	293	-	-	-	-	-	A072B2D0R0-400E

Fuses will carry transformer magnetizing inrush current of 25 times full load amperes for .01 second and 12 times full load current for .1 second
 EJO fuses can be used outdoors without an enclosure ¹ the self cooled rating of the transformer

MAXIMUM FUSE SIZE

The Code allows primary fuses to be sized at 250% of transformer primary current rating or next standard fuse rating. Sizing this large may not provide adequate protection. Maximum fuse size should be determined by making sure the fuse total clearing curve does not exceed transformer damage curve. The transformer manufacturer should be consulted to determine transformer overload and short circuit withstand capability.



3 Phase 7200 Volt Typical Primary Fuse Sizing Chart							
Transformer Rating kVA ¹	Full Load Amperes	2" Ferrule mounting		3" Ferrule mounting (single and double)			Bolt on A072B
		9F60 EJO "C"	9F62 EJO "C"	9F60 EJO "D"	9F62 EJO "D"	A825X	
9	0.72	9F60DJE003	-	-	-	-	-
15	1.2	9F60DJE005	-	-	-	-	-
30	2.4	9F60DJE010	-	-	-	-	-
45	3.6	9F60DJE010	-	-	-	-	-
75	6.0	-	-	9F60FJE020	-	-	-
112.5	9.0	-	9F62HCC020	9F60FJE025	-	-	-
150	12	-	9F62HCC020	9F60FJE040	-	A825X20-1	-
225	18	-	9F62HCC040	9F60FJE050	-	A825X25-1	-
300	24	-	9F62HCC040	9F60FJE065	-	A825X40-1	-
500	40	-	9F62HCC050	9F60FJE100	-	A825X65-1	-
750	60	-	-	9F60HJE125	9F62DCC080	A825X80-1	-
1000	80	-	-	9F60HJE150	9F62DCC125	A825X125-1	-
1500	120	-	-	9F60HJE200	9F62FCC200	A825X200-1	-
2000	161	-	-	-	9F62FCC200	A825X200-1	-
2500	201	-	-	-	9F62FCC250	-	A072B2DOR0-250E
3000	241	-	-	-	-	-	A072B2DOR0-300E
3500	281	-	-	-	-	-	A072B2DOR0-350E
4000	321	-	-	-	-	-	A072B2DOR0-400E

Fuses will carry transformer magnetizing inrush current of 25 times full load amperes for .01 second and 12 times full load current for .1 second

EJO fuses can be used outdoors without an enclosure

¹ the self cooled rating of the transformer

3 Phase 12,000 Volt Typical Primary Fuse Sizing Chart											
Transformer Rating kVA ²	Full Load Amperes	2" Ferrule mounting				3" Ferrule mounting (single and double)			Bolt on		Clip Lock
		9F60 EJ "C"	9F60 EJO "C"	9F62 EJO "C"	A155F	9F60 EJO "D"	9F62 EJO "D"	A155F	9F62 EJO "DDDD"	A155B	
9	0.43	9F60CJH002	9F60DMH002	-	-	-	-	-	-	-	-
15	0.72	9F60CJH003	9F60DMH003	-	-	-	-	-	-	-	-
30	1.4	9F60CJH005	9F60DMH005	-	-	-	-	-	-	-	-
45	2.2	9F60CJH007	9F60DMH007	-	A155F1COR0-5E	-	-	-	-	-	-
75	3.6	9F60CJH010	9F60DMH010	-	A155F1COR0-7E	-	-	-	-	-	-
112.5	5.4	-	-	9F62HDD020	A155F1COR0-10E	9F60FMH020	-	A155F1DOR0-10E	-	-	A155C1DOR0-10E
150	7.2	-	-	9F62HDD020	A155F1COR0-10E	9F60FMH025	-	A155F1DOR0-10E	-	-	A155C1DOR0-10E
225	10.8	-	-	9F62HDD020	A155F1COR0-15E	9F60FMH030	-	A155F1DOR0-15E	-	-	A155C1DOR0-15E
300	14	-	-	9F62HDD025	A155F1COR0-20E	9F60FMH040	-	A155F1DOR0-20E	-	-	A155C1DOR0-20E
500	24	-	-	-	-	9F60HMH065	-	A155F1DOR0-40E	-	-	A155C1DOR0-40E
750	36	-	-	-	-	9F60HMH100	9F62DDD065	A155F1DOR0-50E	-	-	A155C1DOR0-50E
1000	48	-	-	-	-	9F60HMH100	9F62DDD065	A155F1DOR0-65E*	-	-	A155C2DOR0-65E

Fuses will carry transformer magnetizing inrush current of 25 times full load amperes for .01 second and 12 times full load current for .1 second

EJO fuses can be used outdoors without an enclosure

¹ the self cooled rating of the transformer

* use F2 in place of F1 for double barrel fuses

3 Phase 12,470 Volt Typical Primary Fuse Sizing Chart											
Trans- former Rating kVA ¹	Full Load Amp- eres	2" Ferrule mounting				3" Ferrule mounting (single and double)			Bolt on		Clip Lock
		9F60 EJ "C"	9F60 EJO "C"	9F62 EJO "C"	A155F	9F60 EJO "D"	9F62 EJO "D"	A155F	9F62 EJO "DDDD"	A155B	A155C
30	1.4	9F60CJH005	9F60DMH005	-	-	-	-	-	-	-	-
45	2.1	9F60CJH007	9F60DMH007	-	A155F1COR0-5E	-	-	-	-	-	-
75	3.5	9F60CJH010	9F60DMH010	-	A155F1COR0-7E	-	-	-	-	-	-
112.5	5.2	-	-	9F62HDD020	A155F1COR0-10E	9F60FMH020	-	A155F1D0R0-10E	-	-	A155C1D0R0-10E
150	7.0	-	-	9F62HDD020	A155F1COR0-10E	9F60FMH020	-	A155F1D0R0-10E	-	-	A155C1D0R0-10E
225	10	-	-	9F62HDD020	A155F1COR0-15E	9F60FMH025	-	A155F1D0R0-15E	-	-	A155C1D0R0-15E
300	14	-	-	9F62HDD025	A155F1COR0-20E	9F60FMH040	-	A155F1D0R0-20E	-	-	A155C1D0R0-20E
500	23	-	-	9F62HDD030	A155F1COR0-30E	9F60FMH050	-	A155F1D0R0-30E	-	-	A155C1D0R0-30E
750	35	-	-	-	-	9F60HMH065	9F62DDD065	A155F1D0R0-50E	-	-	A155C1D0R0-50E
1000	46	-	-	-	-	9F60HMH080	9F62DDD065	A155F1D0R0-65E*	-	-	A155C1D0R0-65E
1500	70	-	-	-	-	-	9F62DDD100	A155F1D0R0-100E*	-	-	A155C1D0R0-100E
2000	93	-	-	-	-	-	9F62FDD125	A155F2D0R0-125E	-	-	A155C2D0R0-125E
2500	116	-	-	-	-	-	9F62FDD150	A155F2D0R0-150E	-	A155B2D0R0-200E	A155C3D0R0-200E
3000	139	-	-	-	-	-	9F62FDD175	A155F2D0R0-175E	-	A155B2D0R0-200E	A155C3D0R0-200E
3500	162	-	-	-	-	-	9F62FDD200	A155F2D0R0-200E	-	A155B2D0R0-200E	A155C3D0R0-200E
4000	185	-	-	-	-	-	-	-	-	A155B3D0R0-300E	A155C3D0R0-250E
4500	209	-	-	-	-	-	-	-	-	A155B3D0R0-300E	A155C3D0R0-250E
5000	232	-	-	-	-	-	-	-	9F62KED300	A155B3D0R0-300E	A155C3D0R0-300E
5500	255	-	-	-	-	-	-	-	9F62KED300	A155B3D0R0-300E	A155C3D0R0-300E

Fuses will carry transformer magnetizing inrush current of 25 times full load amperes for .01 second and 12 times full load current for .1 second

EJO fuses can be used outdoors without an enclosure

¹ the self cooled rating of the transformer

* use F2 in place of F1 for double barrel fuses

3 Phase 13,200 Volt Typical Primary Fuse Sizing Chart											
Trans- former Rating kVA ¹	Full Load Amp- eres	2" Ferrule mounting				3" Ferrule mounting (single and double)			Bolt on		Clip Lock
		9F60 EJ "C"	9F60 EJO "C"	9F62 EJO "C"	A155F	9F60 EJO "D"	9F62 EJO "D"	A155F	9F62 EJO "DDDD"	A155B	A155C
9	0.4	9F60CJH002	9F60DMH002	-	-	-	-	-	-	-	-
15	0.7	9F60CJH003	9F60DMH003	-	-	-	-	-	-	-	-
30	1.3	9F60CJH005	9F60DMH005	-	-	-	-	-	-	-	-
45	2.0	9F60CJH007	9F60DMH007	-	A155F1COR0-5E	-	-	-	-	-	-
75	3.3	9F60CJH010	9F60DMH010	-	A155F1COR0-7E	-	-	-	-	-	-
112.5	4.9	-	-	-	A155F1COR0-10E	9F60FMH015	-	A155F1D0R0-10E	-	-	A155C1D0R0-10E
150	6.6	-	-	-	A155F1COR0-10E	9F60FMH020	-	A155F1D0R0-10E	-	-	A155C1D0R0-10E
225	10	-	-	9F62HDD020	A155F1COR0-15E	9F60FMH030	-	A155F1D0R0-15E	-	-	A155C1D0R0-15E
300	13	-	-	9F62HDD025	A155F1COR0-20E	9F60FMH040	-	A155F1D0R0-20E	-	-	A155C1D0R0-20E
500	22	-	-	9F62HDD030	A155F1COR0-30E	9F60HMH065	-	A155F1D0R0-30E	-	-	A155C1D0R0-30E
750	33	-	-	-	-	9F60HMH080	9F62DDD050	A155F1D0R0-50E	-	-	A155C1D0R0-50E
1000	44	-	-	-	-	9F60HMH100	9F62DDD065	A155F1D0R0-65E*	-	-	A155C1D0R0-65E
1500	66	-	-	-	-	-	9F62DDD100	A155F1D0R0-100E*	-	-	A155C1D0R0-100E
2000	88	-	-	-	-	-	9F62FDD125	A155F2D0R0-125E	-	-	A155C2D0R0-125E
2500	109	-	-	-	-	-	9F62FDD150	A155F2D0R0-150E	-	-	A155C3D0R0-150E
3000	131	-	-	-	-	-	9F62FDD175	A155F2D0R0-200E	-	A155B2D0R0-200E	A155C3D0R0-200E
3500	153	-	-	-	-	-	9F62FDD200	A155F2D0R0-200E	-	A155B2D0R0-200E	A155C3D0R0-200E
4000	175	-	-	-	-	-	-	-	-	A155B2D0R0-200E	A155C3D0R0-250E
4500	197	-	-	-	-	-	-	-	-	A155B3D0R0-300E	A155C3D0R0-250E
5000	219	-	-	-	-	-	-	-	9F62KED300	A155B3D0R0-300E	A155C3D0R0-300E
5500	241	-	-	-	-	-	-	-	9C62KED300	A155B3D0R0-300E	A155C3D0R0-300E

Fuses will carry transformer magnetizing inrush current of 25 times full load amperes for .01 second and 12 times full load current for .1 second

EJO fuses can be used outdoors without an enclosure

¹ the self cooled rating of the transformer

* use F2 in place of F1 for double barrel fuses

Primary Fuses for MV 3-PHASE POWER TRANSFORMERS

APPLICATION
INFORMATION

3 Phase 13,800 Volt Typical Primary Fuse Sizing Chart											
Transformer Rating kVA ¹	Full Load Amperes	2" Ferrule mounting				3" Ferrule mounting (single and double)			Bolt on		Clip Lock
		9F60 EJ "C"	9F60 EJO "C"	9F62 EJO "C"	A155F	9F60 EJO "D"	9F62 EJO "D"	A155F	9F62 EJO "DDDD"	A155B	A155C
30	1	9F60CJH005	9F60DMH005	-	-	-	-	-	-	-	-
45	2	9F60CJH007	9F60DMH007	-	A155F1COR0-5E	-	-	-	-	-	-
75	3	9F60CJH010	9F60DMH010	-	A155F1COR0-7E	-	-	-	-	-	-
112.5	5	-	-	-	A155F1COR0-10E	9F60FMH015	-	A155F1DOR0-10E	-	-	A155C1DOR0-10E
150	6	-	-	-	A155F1COR0-10E	9F60FMH020	-	A155F1DOR0-10E	-	-	A155C1DOR0-10E
225	9	-	-	9F62HDD020	A155F1COR0-15E	9F60FMH030	-	A155F1DOR0-15E	-	-	A155C1DOR0-15E
300	13	-	-	9F62HDD025	A155F1COR0-20E	9F60FMH030	-	A155F1DOR0-20E	-	-	A155C1DOR0-20E
500	21	-	-	9F62HDD030	A155F1COR0-30E	9F60FMH040	-	A155F1DOR0-30E	-	-	A155C1DOR0-30E
750	31	-	-	-	-	9F60HMH065	9F62DDD050	A155F1DOR0-50E	-	-	A155C1DOR0-50E
1000	42	-	-	-	-	9F60HMH080	9F62DDD065	A155F1DOR0-65E*	-	-	A155C1DOR0-65E
1500	63	-	-	-	-	9F60HMH100	9F62DDD100	A155F1DOR0-100E*	-	-	A155C1DOR0-100E
2000	84	-	-	-	-	-	9F62FDD125	A155F2DOR0-125E	-	-	A155C2DOR0-125E
2500	105	-	-	-	-	-	9F62FDD150	A155F2DOR0-150E	-	-	A155C3DOR0-150E
3000	126	-	-	-	-	-	9F62FDD200	A155F2DOR0-200E	-	A155B2DOR0-200E	A155C3DOR0-200E
3500	147	-	-	-	-	-	9F62FDD200	A155F2DOR0-200E	-	A155B2DOR0-200E	A155C3DOR0-200E
4000	168	-	-	-	-	-	-	-	-	A155B3DOR0-300E	A155C3DOR0-250E
4500	188	-	-	-	-	-	-	-	-	A155B3DOR0-300E	A155C3DOR0-250E
5000	209	-	-	-	-	-	-	-	-	A155B3DOR0-300E	A155C3DOR0-300E
5500	230	-	-	-	-	-	-	-	9F62KED300	A155B3DOR0-300E	A155C3DOR0-300E
6000	251	-	-	-	-	-	-	-	9F62KED300	A155B3DOR0-300E	A155C3DOR0-300E

Fuses will carry transformer magnetizing inrush current of 25 times full load amperes for .01 second and 12 times full load current for .1 second

EJO fuses can be used outdoors without an enclosure

¹ the self cooled rating of the transformer

* use F2 in place of F1 for double barrel fuses

3 Phase 14,400 Volt Typical Primary Fuse Sizing Chart											
Transformer Rating kVA ¹	Full Load Amperes	2" Ferrule mounting				3" Ferrule mounting (single and double)			Bolt on		Clip Lock
		9F60 EJ "C"	9F60 EJO "C"	9F62 EJO "C"	A155F	9F60 EJO "D"	9F62 EJO "D"	A155F	9F62 EJO "DDDD"	A155B	A155C
9	0.4	9F60DMH002	9F60CJH002	-	-	-	-	-	-	-	-
15	0.6	9F60DMH003	9F60CJH003	-	-	-	-	-	-	-	-
30	1.2	9F60DMH005	9F60CJH005	-	-	-	-	-	-	-	-
45	1.8	9F60DMH007	9F60CJH007	-	A155F1COR0-5E	-	-	-	-	-	-
75	3.0	9F60DMH010	9F60CJH010	-	A155F1COR0-7E	-	-	-	-	-	-
112.5	5	-	-	-	A155F1COR0-10E	9F60FMH015	-	A155F1DOR0-10E	-	-	A155C1DOR0-10E
150	6	-	-	-	A155F1COR0-10E	9F60FMH020	-	A155F1DOR0-10E	-	-	A155C1DOR0-10E
225	9	-	-	9F62HDD020	A155F1COR0-15E	9F60FMH030	-	A155F1DOR0-15E	-	-	A155C1DOR0-15E
300	12	-	-	9F62HDD020	A155F1COR0-20E	9F60FMH040	-	A155F1DOR0-20E	-	-	A155C1DOR0-20E
500	20	-	-	9F62HDD030	A155F1COR0-30E	9F60FMH050	-	A155F1DOR0-30E	-	-	A155C1DOR0-30E
750	30	-	-	-	-	9F60FMH080	9F62DDD050	A155F1DOR0-40E	-	-	A155C1DOR0-50E
1000	40	-	-	-	-	9F60FMH100	9F62DDD065	A155F1DOR0-65E*	-	-	A155C1DOR0-65E
1500	60	-	-	-	-	-	9F62DDD080	A155F1DOR0-80E*	-	-	A155C1DOR0-100E
2000	80	-	-	-	-	-	9F62FDD125	A155F2DOR0-125E	-	-	A155C2DOR0-125E
2500	100	-	-	-	-	-	9F62FDD150	A155F2DOR0-150E	-	-	A155C3DOR0-150E
3000	120	-	-	-	-	-	9F62FDD175	A155F2DOR0-175E	-	A155B2DOR0-200E	A155C3DOR0-200E
3500	140	-	-	-	-	-	9F62FDD200	A155F2DOR0-200E	-	A155B2DOR0-200E	A155C3DOR0-200E
4000	161	-	-	-	-	-	-	-	-	A155B2DOR0-200E	A155C3DOR0-250E
4500	181	-	-	-	-	-	-	-	-	A155B3DOR0-300E	A155C3DOR0-250E
5000	201	-	-	-	-	-	-	-	-	A155B3DOR0-300E	A155C3DOR0-300E
5500	221	-	-	-	-	-	-	-	9F62KED300	A155B3DOR0-300E	A155C3DOR0-300E
6000	241	-	-	-	-	-	-	-	9F62KED300	A155B3DOR0-300E	A155C3DOR0-300E

Fuses will carry transformer magnetizing inrush current of 25 times full load amperes for .01 second and 12 times full load current for .1 second

EJO fuses can be used outdoors without an enclosure

¹ the self cooled rating of the transformer

* use F2 in place of F1 for double barrel fuses

AP

3 Phase 22,000 Volt Typical Primary Fuse Sizing Chart			
Transformer Rating kVA ¹	Full Load Amperes	2" Ferrule mounting	3" Ferrule mounting (single and double)
		9F60 EJO "C"	9F60 EJO "D"
30	0.79	9F60DNJ003	-
45	1.18	9F60DNJ004	-
75	1.97	9F60DNJ005	-
112.5	2.95	9F60DNJ006	-
150	3.93	9F60DNJ010	-
225	5.9	-	9F60FNJ020
300	7.84	-	9F60FNJ020
500	13.1	-	9F60FNJ030
750	19.7	-	9F60FNJ050
1000	26.2	-	9F60HNJ065
1500	39.4	-	9F60HNJ080
2000	52.4	-	9F60HNJ100

Fuses will carry transformer magnetizing inrush current of 25 times full load amperes for .01 second and 12 times full load current for .1 second
 EJO fuses can be used outdoors without an enclosure
¹ the self cooled rating of the transformer

3 Phase 33,000 Volt Typical Primary Fuse Sizing Chart			
Transformer Rating kVA ¹	Full Load Amperes	3" Ferrule mounting (single and double)	
		9F60 EJO "D" with indicator	9F60 EJO "D" without indicator
45	0.79	9F60FPK002	9F60FPT002
75	1.31	9F60FPK005	9F60FPT005
112.5	1.98	9F60FPK005	9F60FPT005
150	2.62	9F60FPK007	9F60FPT007
225	3.96	9F60FPK010	9F60FPT010
300	5.26	9F60FPK015	9F60FPT015
500	8.71	9F60FPK025	9F60FPT025
750	13.1	9F60FPK030	9F60FPT030
1000	17.5	9F60FPK040	9F60FPT040
1500	26.2	9F60HPK065	9F60HPT065
2000	35	9F60HPK065	9F60HPT065
2500	43.7	9F60HPK080	9F60HPT080

Fuses will carry transformer magnetizing inrush current of 25 times full load amperes for .01 second and 12 times full load current for .1 second
 EJO fuses can be used outdoors without an enclosure
¹ the self cooled rating of the transformer

Current limitation is one of the important benefits provided by modern fuses. Current-limiting fuses are capable of isolating a faulted circuit before the fault current has sufficient time to reach its maximum value. This current-limiting action provides several benefits:

- It limits thermal and mechanical stresses created by the fault currents.
- It reduces the magnitude and duration of the system voltage drop caused by fault currents.
- Current-limiting fuses can be precisely and easily coordinated under even short circuit conditions to minimize unnecessary service interruption.

Peak let-thru current (I_p) and I^2t are two measures of the degree of current limitation provided by a fuse. Maximum allowable I_p and I^2t values are specified in UL standards for all UL listed current-limiting fuses, and are available on all semiconductor fuses.

LET-THRU CURRENT

Let-thru current is that current passed by a fuse while the fuse is interrupting a fault within the fuse's current-limiting range. Figure 1 illustrates this. Let-thru current is expressed as a peak instantaneous value (I_p).

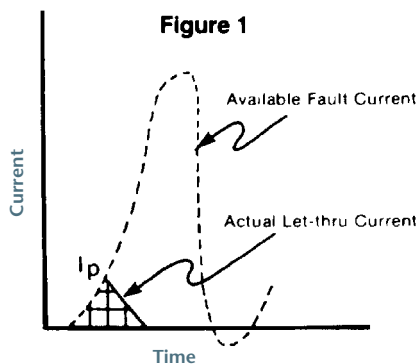

I_p

I_p data is generally presented in the form of a graph. Let's review the key information provided by a peak let-thru graph. Figure 2 shows the important components.

- (1) The X-axis is labeled "Available Fault Current" in RMS symmetrical amperes.
- (2) The Y-axis is labeled as "Instantaneous Peak Let-Thru Current" in amperes.

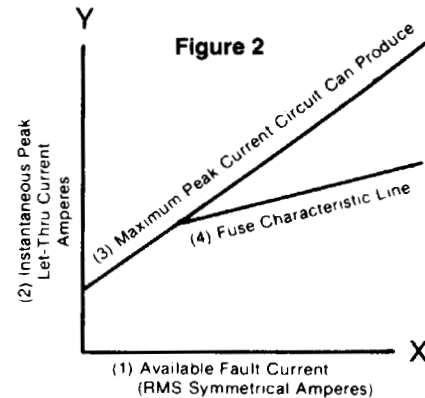

- (3) The line labeled "Maximum Peak Current Circuit Can Produce" gives the worst case peak current possible with no fuse in the circuit.
- (4) The fuse characteristic line is a plot of the peak let-thru currents which are passed by a given fuse at various available fault currents.

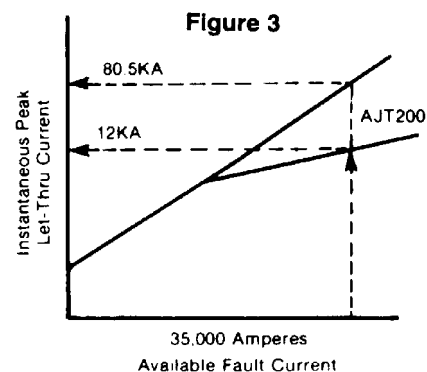
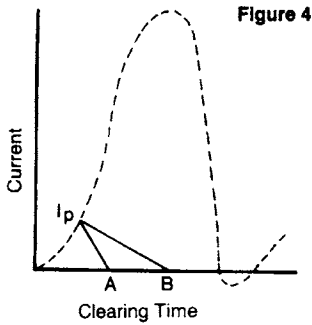

Figure 3 illustrates the use of the peak let-thru current graph. Assume that a 200 ampere Class J fuse (#AJT200) is to be applied where the available fault current is 35,000 amperes RMS. The graph shows that with 35,000 amperes RMS available, the peak available current is 80,500 amperes ($35,000 \times 2.3$) and that the fuse will limit the peak let-thru current to 12,000 amperes.

Why is the peak available current 2.3 times greater than the RMS available current? In theory, the peak available fault current can be anywhere from 1.414 x (RMS available) to 2.828 x (RMS available) in a circuit where the impedance is all reactance with no resistance. In reality all circuits include some resistance and the 2.3 multiplier has been chosen as a practical limit.

I_p VERSUS I²T

I_p has a rather limited application usefulness. Two fuses can have the same I_p but different total clearing times. See Figure 4.



The fuse that clears in time A will provide better component protection than will the fuse that clears in time B.

Fuse clearing I²t takes into account I_p and total clearing time. Fuse clearing I²t values are derived from oscillograms of fuses tested within their current-limiting range and are calculated as follows:

The “t” in the equation is the total clearing time for the fuse. To be proper, I²t should be written as (I_{RMS})²t. It is generally understood that the “I” in I²t is really I_{RMS}, and the RMS is dropped for the sake of brevity.

$$I^2t = \int_0^t I^2 dt$$

Note, from Figure 4, since clearing time “B” is approximately twice clearing time “A”, the resultant I²t for that fuse will be at least twice the I²t for the fuse with clearing time “A” and its level of protection will be correspondingly lower.

The I²t passed by a given fuse is dependent upon the characteristics of the fuse and also upon the applied voltage. The I²t passed by a given fuse will decrease as the application voltage decreases. Unless stated otherwise, published I²t values are

based on AC testing. The I²t passed by a fuse in a DC application may be higher or lower than in an AC application. The voltage, available fault current and time constant of the DC circuit are the determining factors.

Fuse I²t value can be used to determine the level of protection provided to circuit components under fault current conditions. Manufacturers of diodes, thyristors, triacs, and cable publish I²t withstand ratings for their products. The fuse chosen to protect these products should have a clearing I²t that is lower than the withstand I²t of the device being protected.

FUSE LET-THRU TABLES

APPARENT RMS SYMMETRICAL LET-THRU CURRENT

Although the current-limiting characteristics of current-limiting fuses are represented in Peak Let-Thru charts, an increasingly easy to use method of presenting this data uses Peak Let-Thru tables. The tables are based on Peak Let-Thru charts and reflect fuse tests at 15% power factor at rated voltage with prospective fault currents as high as 200,000 amperes. At each prospective fault current, let-thru data is given in two forms for an individual fuse - I_{rms} and I_p. Where I_{rms} is the “Apparent RMS Symmetrical Current” and I_p is the maximum peak instantaneous current passed by the fuse, the I_p let-thru current is 2.3 times I_{rms}. This relationship exists between peak current and RMS available current under worst-case test conditions (i.e. closing angle of 0° at 15% power factor).

Let-thru tables are easier to read than let-thru charts. Presenting let-thru data in table versus chart format reduces the possibility of misreading the information and saves time. These tables are also helpful when comparing the current-limiting capability of various fuses.

APPARENT RMS SYMMETRICAL LET-THRU CURRENT

Table 1 - Class L, A4BQ Fuses at 600 Volts AC, 15% Power Factor

Prospective Short Circuit Rms. Sym Amperes	Fuse Let-Thru Current In Kilo-Amperes																					
	By Fuse Rating In Amperes																					
	601		800		1000		1200		1600		2000		2500		3000		4000		5000		6000	
	I_{rms}	I_p	I_{rms}	I_p	I_{rms}	I_p	I_{rms}	I_p	I_{rms}	I_p	I_{rms}	I_p	I_{rms}	I_p	I_{rms}	I_p	I_{rms}	I_p	I_{rms}	I_p	I_{rms}	I_p
10,000	7.4	17	8.7	20	10	23	10	23	10	23	10	23	10	23	10	23	10	23	10	23	10	23
15,000	8.3	19	10	23	12	27	13	30	15	35	15	35	15	35	15	35	15	35	15	35	15	35
20,000	9.1	21	11	25	13	29	14	33	17	39	20	46	20	46	20	46	20	46	20	46	20	46
25,000	9.8	23	12	27	13	31	15	35	18	42	22	50	25	58	25	58	25	58	25	58	25	58
30,000	10	24	13	29	14	33	16	37	20	45	23	53	29	66	30	69	30	69	30	69	30	69
35,000	11	25	13	30	15	35	17	39	20	47	24	56	30	69	35	81	35	81	35	81	35	81
40,000	12	27	14	32	16	37	18	41	21	49	25	58	31	72	36	83	40	92	40	92	40	92
50,000	13	29	15	34	17	40	19	44	23	53	27	63	34	78	39	89	48	111	50	115	50	115
60,000	13	30	16	36	18	42	20	47	25	57	29	67	36	83	41	94	51	118	60	138	60	138
80,000	14	33	17	40	20	46	23	52	27	62	32	73	40	91	45	104	57	130	67	153	77	176
100,000	16	36	19	43	22	50	24	56	29	67	34	79	43	98	49	112	61	140	72	165	83	190
150,000	18	41	21	49	25	57	28	64	33	77	39	90	49	112	56	128	70	160	82	189	94	217
200,000	20	45	24	54	27	63	31	71	37	84	43	100	53	123	61	141	77	176	90	208	104	239

Table 2 - Class L, A4BY Fuses at 600 Volts AC, 15% Power Factor

Prospective Short Circuit Rms. Sym Amperes	Fuse Let-Thru Current In Kilo-Amperes																	
	By Fuse Rating In Amperes																	
	601		800		1000		1200		1600		2000		2500		3000		4000	
	I_{rms}	I_p	I_{rms}	I_p	I_{rms}	I_p	I_{rms}	I_p	I_{rms}	I_p	I_{rms}	I_p	I_{rms}	I_p	I_{rms}	I_p	I_{rms}	I_p
15,000	11	24	13	29	15	35	15	35	15	35	15	35	15	35	15	35	15	35
20,000	12	26	14	32	16	37	19	43	20	46	20	46	20	46	20	46	20	46
25,000	13	29	15	34	18	40	20	46	24	55	25	58	25	58	25	58	25	58
30,000	13	30	16	36	19	43	21	49	25	58	29	67	30	69	30	69	30	69
35,000	14	32	17	38	20	45	23	52	27	61	30	70	33	76	35	81	35	81
40,000	15	34	17	40	21	47	24	54	28	64	32	73	35	79	37	86	40	92
50,000	16	36	19	43	22	51	25	58	30	68	34	78	37	86	41	95	50	115
60,000	17	38	20	45	24	54	27	62	31	72	37	84	40	91	44	100	53	121
80,000	18	42	22	50	26	59	29	67	35	80	40	92	44	100	48	110	58	133
100,000	20	45	24	54	28	64	32	73	38	87	43	99	47	108	52	119	62	143
150,000	23	52	27	62	32	73	37	84	43	99	49	113	54	123	59	137	73	167
200,000	25	56	29	67	35	80	40	91	48	110	54	123	59	136	65	150	79	181

Table 3 - Class L, A4BT Fuses at 600 Volts AC, 15% Power Factor

Prospective Short Circuit Rms. Sym Amperes	Fuse Let-Thru Current In Kilo-Amperes									
	By Fuse Rating In Amperes									
	800		1000		1200		1600		2000	
	I_{rms}	I_p	I_{rms}	I_p	I_{rms}	I_p	I_{rms}	I_p	I_{rms}	I_p
15,000	14	33	15	35	15	35	15	35	15	35
20,000	16	36	18	41	20	46	20	46	20	46
25,000	17	39	19	45	22	50	25	58	25	58
30,000	18	41	21	48	23	54	28	63	30	69
35,000	19	43	22	50	25	56	29	67	34	79
40,000	20	45	23	52	26	59	30	70	35	81
50,000	21	49	25	56	28	63	33	75	38	87
60,000	23	52	26	60	29	67	35	80	40	93
80,000	25	57	29	66	32	74	38	88	44	102
100,000	27	62	31	71	35	80	41	95	48	110
150,000	31	70	35	81	40	92	47	109	55	126
200,000	34	78	39	89	44	101	52	120	60	139

AP

APPARENT RMS SYMMETRICAL LET-THRU CURRENT

Table 4 - Class RK1, A6K Fuses at 600 Volts AC, 15% Power Factor

Prospective Short Circuit Rms. Sym Amperes	Fuse Let-Thru Current In Kilo-Amperes											
	By Fuse Rating In Amperes											
	30		60		100		200		400		600	
	rms	p	rms	p	rms	p	rms	p	rms	p	rms	p
5,000	.63	1.4	1.4	3.2	2.0	4.6	3.2	7.4	4.6	11	5.0	11.5
10,000	.80	1.8	1.7	3.9	2.6	6.0	4.0	9.2	5.8	13	7.5	17
15,000	.91	2.1	2.0	4.6	2.9	6.7	4.6	11	6.7	15	8.6	20
20,000	1.0	2.3	2.2	5.1	3.2	7.4	5.0	12	7.4	17	9.5	22
25,000	1.1	2.5	2.4	5.5	3.5	8.1	5.4	12	7.9	18	10	23
30,000	1.2	2.6	2.5	5.8	3.7	8.5	5.8	13	8.4	19	11	25
35,000	1.2	2.8	2.6	6.0	3.9	9.0	6.1	14	8.9	20	11	26
40,000	1.3	2.9	2.8	6.4	4.1	9.4	6.3	14	9.3	21	12	27
50,000	1.4	3.1	3.0	6.9	4.4	10	6.8	16	10	23	13	30
60,000	1.4	3.3	3.2	7.4	4.7	11	7.3	17	11	24	14	32
80,000	1.6	3.7	3.5	8.1	5.1	12	8.0	18	12	27	15	35
100,000	1.7	3.9	3.7	8.5	5.5	13	8.6	20	13	29	16	37
150,000	2.0	4.5	4.4	9.9	6.3	14	9.9	23	14	33	19	43
200,000	2.2	4.9	4.7	11	7.0	16	11	25	16	37	20	47

Table 5 - Class RK1, A6D Fuses at 600 Volts AC, 15% Power Factor

Prospective Short Circuit Rms. Sym Amperes	Fuse Let-Thru Current In Kilo-Amperes											
	By Fuse Rating In Amperes											
	30		60		100		200		400		600	
	rms	p	rms	p	rms	p	rms	p	rms	p	rms	p
5,000	.80	1.8	1.5	3.5	2.0	4.6	3.5	8.0	5.0	12	-	-
10,000	1.0	2.3	1.9	4.4	2.5	5.8	4.4	10.1	7.1	16.4	10	23
15,000	1.2	2.7	2.2	4.9	2.9	6.6	5.0	11.6	8.2	18.8	12	27
20,000	1.3	2.9	2.4	5.4	3.1	7.1	5.5	12	9.0	20.7	13	29
25,000	1.4	3.2	2.6	5.9	3.4	7.8	6.0	13.8	9.7	22.3	14	32
30,000	1.5	3.4	2.7	6.2	3.6	8.3	6.3	14.6	10.3	23.6	15	33
35,000	1.5	3.5	2.9	6.6	3.8	8.7	6.7	15.4	10.8	24.9	15	35
40,000	1.6	3.7	3.0	6.9	4.0	9.1	7.0	16.5	11.3	26	16	37
50,000	1.7	4.0	3.2	7.4	4.3	9.8	7.5	16.5	12.2	28	17	40
60,000	1.8	4.2	3.4	7.8	4.5	11	8.0	17	13	30	18	42
80,000	2.0	4.7	3.8	8.6	5.0	12	8.8	20.3	13	33	20	46
100,000	2.2	5.0	4.1	9.3	5.4	12	9.5	20	14	35	22	50
150,000	2.5	5.8	4.6	11	6.1	14	10.9	25	16	40	25	57
200,000	2.8	6.3	5.1	12	6.8	16	11	25	19	45	27	63

Table 6 - Class J, A4J Fuses at 600 Volts AC, 15% Power Factor

Prospective Short Circuit Rms. Sym Amperes	Fuse Let-Thru Current In Kilo-Amperes											
	By Fuse Rating In Amperes											
	30		60		100		200		400		600	
	rms	p	rms	p	rms	p	rms	p	rms	p	rms	p
5,000	.85	2.0	1.4	3.2	2.0	4.6	3.1	7.2	4.5	10	5.0	12
10,000	1.1	2.5	1.8	4.4	2.8	6.4	3.6	8.2	5.7	13	8.7	20
15,000	1.2	2.8	2.0	4.6	2.9	6.6	4.1	9.4	6.5	15	9.9	23
20,000	1.4	3.1	2.4	5.1	3.2	7.3	4.5	10	7.1	16	11	25
25,000	1.5	3.4	2.4	5.5	3.8	8.7	5.3	12	7.7	18	12	27
30,000	1.6	3.6	2.5	5.8	4.0	9.2	5.5	13	8.2	19	13	29
35,000	1.6	3.7	2.7	6.2	4.2	9.7	5.9	14	8.6	20	13	30
40,000	1.7	3.9	2.8	6.4	4.5	10	6.0	14	9.0	21	14	32
50,000	1.8	4.2	3.0	6.9	4.7	11	6.1	14	9.7	22	15	34
60,000	2.0	4.5	3.2	7.4	5.0	11	6.5	15	10	23	16	36
80,000	2.2	4.9	3.5	8.1	5.5	12	7.1	16	11	25	17	40
100,000	2.3	5.3	3.8	9.5	6.0	14	7.7	18	12	28	19	43
150,000	2.7	6.1	4.7	10.9	6.8	16	8.8	20	14	32	21	49
200,000	2.9	6.7	4.8	11	7.5	17	9.7	22	15	35	24	54

APPARENT RMS SYMMETRICAL LET-THRU CURRENT

Table 7 - Class J, AJT Fuses at 600 Volts AC, 15% Power Factor

Prospective Short Circuit Rms. Sym Amperes	Fuse Let-Thru Current In Kilo-Amperes											
	By Fuse Rating In Amperes											
	30		60		100		200		400		600	
	I_{rms}	I_p	I_{rms}	I_p	I_{rms}	I_p	I_{rms}	I_p	I_{rms}	I_p	I_{rms}	I_p
5,000	.79	1.8	1.2	2.8	1.8	4.0	3.1	7.0	4.8	11	5.0	12
10,000	1.0	2.3	1.6	3.6	2.2	5.1	3.8	8.8	6.0	14	8.3	19
15,000	1.2	2.6	1.8	4.1	2.5	5.8	4.4	10	6.9	16	9.5	22
20,000	1.3	2.9	2.0	4.5	2.8	6.4	4.8	11	7.6	18	11	24
25,000	1.4	3.1	2.1	4.8	3.0	6.9	5.2	12	8.2	19	11	26
30,000	1.4	3.3	2.2	5.1	3.2	7.4	5.5	13	8.7	20	12	28
35,000	1.5	3.5	2.4	5.4	3.4	7.7	5.8	13	9.1	21	13	29
40,000	1.6	3.7	2.5	5.6	3.5	8.1	6.1	14	9.6	22	13	30
50,000	1.7	3.9	2.7	6.1	3.8	8.7	6.6	15	10.3	24	14	33
60,000	1.8	4.2	2.8	6.4	4.0	9.2	7.0	16	11	25	15	35
80,000	2.0	4.6	3.1	7.1	4.4	10	7.7	18	12	28	17	38
100,000	2.2	4.9	3.3	7.6	4.8	11	8.3	19	13	30	18	41
150,000	2.5	5.7	3.8	8.7	5.4	12	9.5	22	15	34	21	47
200,000	2.7	6.2	4.2	9.7	6.0	14	10.4	24	16	37	23	59

Table 8 - Class T, A6T Fuses at 600 Volts AC, 15% Power Factor

Prospective Short Circuit Rms. Sym Amperes	Fuse Let-Thru Current In Kilo-Amperes													
	By Fuse Rating In Amperes													
	30		60		100		200		400		600		800	
	I_{rms}	I_p	I_{rms}	I_p	I_{rms}	I_p	I_{rms}	I_p	I_{rms}	I_p	I_{rms}	I_p	I_{rms}	I_p
5,000	.62	1.4	1.2	2.8	1.6	3.8	2.6	6.0	4.2	9.7	5.0	12	5.0	12
10,000	.78	1.8	1.5	3.5	2.1	4.8	3.3	7.5	5.3	12	8.2	19	10	22
15,000	.89	2.1	1.7	4.0	2.4	5.4	3.7	8.6	6.1	14	9.4	22	11	26
20,000	.98	2.3	1.9	4.4	2.6	6.0	4.1	9.5	6.7	15	10	24	12	28
25,000	1.1	2.4	2.0	4.8	2.8	6.5	4.4	10	7.2	17	11	26	13	31
30,000	1.1	2.6	2.2	5.0	3.0	6.9	4.7	11	7.7	18	12	27	14	32
35,000	1.2	2.7	2.3	5.3	3.1	7.2	5.0	11	8.1	19	12	29	15	34
40,000	1.2	2.9	2.4	5.6	3.3	7.5	5.2	12	8.5	19	13	30	16	36
50,000	1.3	3.1	2.6	6.0	3.5	8.1	5.6	13	9.1	21	14	32	17	38
60,000	1.4	3.3	2.8	6.4	3.8	8.6	5.9	14	9.7	22	15	34	18	41
80,000	1.6	3.6	3.0	7.0	4.1	9.5	6.5	15	11	25	16	38	20	45
100,000	1.7	3.9	3.2	7.5	4.5	10	7.0	16	11	26	18	40	21	48
150,000	1.9	4.4	3.8	8.6	5.1	12	8.1	19	13	30	20	46	24	55
200,000	2.1	4.9	4.1	9.5	5.6	13	8.9	20	14	33	22	51	27	61

Table 9 - Class T, A3T Fuses at 300 Volts AC, 15% Power Factor

Prospective Short Circuit Rms. Sym Amperes	Fuse Let-Thru Current In Kilo-Amperes															
	By Fuse Rating In Amperes															
	30		60		100		200		400		600		800		1200	
	I_{rms}	I_p	I_{rms}	I_p	I_{rms}	I_p	I_{rms}	I_p	I_{rms}	I_p	I_{rms}	I_p	I_{rms}	I_p	I_{rms}	I_p
5,000	.53	1.2	.95	2.2	1.4	3.1	2.0	4.6	3.0	6.9	4.5	10	5.0	12	5.0	12
10,000	.66	1.5	1.2	2.8	1.7	3.9	2.5	5.8	3.8	8.7	5.6	13	7.2	16	9.3	21
15,000	.76	1.7	1.4	3.2	2.0	4.5	2.9	6.6	4.4	10	6.4	15	8.2	19	11	24
20,000	.83	1.9	1.5	3.5	2.1	4.8	3.1	7.1	4.8	11	7.0	16	9.0	21	12	27
25,000	.90	2.1	1.6	3.7	2.3	5.3	3.4	7.8	5.2	12	7.6	17	9.7	22	13	29
30,000	.96	2.2	1.7	3.9	2.5	5.6	3.6	8.3	5.5	13	8.1	19	10	24	13	31
35,000	1.0	2.3	1.8	4.1	2.6	6.0	3.8	8.7	5.8	13	8.5	20	11	25	14	32
40,000	1.1	2.4	1.9	4.4	2.7	6.2	4.0	9.2	6.0	14	8.9	20	11	26	15	34
50,000	1.1	2.6	2.1	4.7	2.9	6.7	4.3	9.9	6.5	15	9.6	22	12	28	16	37
60,000	1.2	2.8	2.2	5.1	3.1	7.1	4.5	10	6.9	16	10	23	13	30	17	39
80,000	1.3	3.1	2.4	5.5	3.4	7.8	5.0	12	7.6	17	11	26	14	33	19	43
100,000	1.4	3.3	2.6	6.0	3.7	8.4	5.4	12	8.2	19	12	28	15	35	20	46
150,000	1.6	3.7	3.0	6.8	4.2	9.7	6.1	14	9.4	22	14	32	18	41	23	53
200,000	1.8	4.1	3.3	7.5	4.6	11	6.8	16	10	24	15	35	19	45	25	58

APPARENT RMS SYMMETRICAL LET-THRU CURRENT

Table 10 - Class RK1, A2K Fuses at 250 Volts AC, 15% Power Factor

Prospective Short Circuit Rms. Sym Amperes	Fuse Let-Thru Current In Kilo-Amperes											
	By Fuse Rating In Amperes											
	30		60		100		200		400		600	
	I_{rms}	I_p	I_{rms}	I_p	I_{rms}	I_p	I_{rms}	I_p	I_{rms}	I_p	I_{rms}	I_p
5,000	.61	1.4	1.4	3.2	1.7	4.0	2.9	6.7	4.4	10	5.0	12
10,000	.77	1.8	1.7	4.0	2.2	5.0	3.7	8.5	5.5	13	7.4	17
15,000	.88	2.0	2.0	4.6	2.5	5.8	4.2	9.7	6.3	14	8.5	19
20,000	.97	2.2	2.2	5.0	2.8	6.3	4.6	11	6.9	16	9.3	21
25,000	1.1	2.4	2.4	5.4	3.0	6.8	5.0	12	7.4	17	10	23
30,000	1.1	2.6	2.5	5.8	3.2	7.3	5.3	12	7.9	18	11	25
35,000	1.2	2.7	2.6	6.0	3.3	7.7	5.6	13	8.3	19	11	26
40,000	1.2	2.8	2.8	6.3	3.5	8.0	5.9	13	8.7	20	12	27
50,000	1.3	3.0	3.0	6.8	3.8	8.6	6.3	14	9.4	22	13	29
60,000	1.4	3.2	3.2	7.2	4.0	9.2	6.7	15	10	23	13	31
80,000	1.5	3.5	3.5	8.0	4.4	10	7.4	17	11	25	15	34
100,000	1.7	3.8	3.7	8.6	4.7	11	7.9	18	12	27	16	37
150,000	1.9	4.4	4.3	9.8	5.4	12	9.1	21	14	31	18	42
200,000	2.1	4.8	4.7	11	6.0	14	10	23	15	34	20	46

Table 11 - Class RK1, A2D Fuses at 250 Volts AC, 15% Power Factor

Prospective Short Circuit Rms. Sym Amperes	Fuse Let-Thru Current In Kilo-Amperes											
	By Fuse Rating In Amperes											
	30		60		100		200		400		600	
	I_{rms}	I_p	I_{rms}	I_p	I_{rms}	I_p	I_{rms}	I_p	I_{rms}	I_p	I_{rms}	I_p
5,000	.77	1.8	1.4	3.2	2.0	4.6	3.2	7.3	5.0	12	5.0	12
10,000	.97	2.2	1.8	4.0	2.5	5.8	4.0	9.2	6.4	15	8.0	18
15,000	1.1	2.6	2.0	4.6	2.9	6.6	4.6	11	7.3	17	9.2	21
20,000	1.2	2.8	2.2	5.1	3.2	7.3	5.0	12	8.1	19	10	23
25,000	1.3	3.0	2.4	5.5	3.4	7.9	5.4	12	8.7	20	11	25
30,000	1.4	3.2	2.5	5.8	3.6	8.3	5.8	13	9.2	21	12	27
35,000	1.5	3.4	2.7	6.1	3.8	8.8	6.1	14	9.7	22	12	28
40,000	1.5	3.5	2.8	5.7	4.0	9.2	6.4	15	10	23	13	29
50,000	1.7	3.8	3.0	6.9	4.3	9.9	6.8	16	11	25	14	32
60,000	1.8	4.0	3.2	7.3	4.6	11	7.3	17	12	27	15	34
80,000	1.9	4.5	3.5	8.1	5.0	12	8.0	18	13	29	16	37
100,000	2.1	4.8	3.8	8.7	5.4	12	8.6	20	14	32	17	40
150,000	2.4	5.5	4.3	9.9	6.2	14	9.9	23	16	36	20	46
200,000	2.6	6.0	4.8	11	6.8	16	11	25	17	40	22	50

Table 12 - Class RK5, TRS Fuses at 600 Volts AC, 15% Power Factor

Prospective Short Circuit Rms. Sym Amperes	Fuse Let-Thru Current In Kilo-Amperes											
	By Fuse Rating In Amperes											
	30		60		100		200		400		600	
	I_{rms}	I_p	I_{rms}	I_p	I_{rms}	I_p	I_{rms}	I_p	I_{rms}	I_p	I_{rms}	I_p
5,000	1.7	3.9	3.2	7.4	3.4	7.8	5.0	12	-	-	-	-
10,000	2.1	4.8	4.0	9.2	4.2	9.7	6.2	14	10	23	10	23
15,000	2.4	5.5	4.6	11	4.8	11	7.1	16	12	27	15	35
20,000	2.7	6.2	5.1	12	5.3	12	7.8	18	13	30	18	42
25,000	2.9	6.7	5.5	13	5.7	13	8.4	19	14	32	20	45
30,000	3.1	7.1	5.8	13	6.1	14	8.9	20	15	35	21	48
35,000	3.3	7.6	6.1	14	6.4	15	9.4	22	16	36	22	50
40,000	3.4	7.8	6.4	15	6.7	15	9.8	23	17	38	23	53
50,000	3.7	8.5	6.9	16	7.2	17	11	24	18	41	25	57
60,000	3.9	9.0	7.3	17	7.7	18	11	26	19	43	26	60
80,000	4.3	9.9	8.1	19	8.5	20	12	29	21	48	29	66
100,000	4.6	11	8.7	20	9.1	21	13	31	22	52	31	72
150,000	5.3	12	9.9	23	10	24	15	35	26	59	36	82
200,000	5.8	13	11	25	12	26	17	39	28	65	39	90

APPARENT RMS SYMMETRICAL LET-THRU CURRENT

Table 13 - Class RK5, TR Fuses at 250 Volts AC, 15% Power Factor

Prospective Short Circuit Rms. Sym Amperes	Fuse Let-Thru Current In Kilo-Amperes											
	By Fuse Rating In Amperes											
	30		60		100		200		400		600	
	rms	p	rms	p	rms	p	rms	p	rms	p	rms	p
5,000	1.4	3.2	3.0	6.9	3.2	7.4	5.0	12	-	-	-	-
10,000	1.8	4.1	3.8	8.7	4.1	9.4	6.6	15	10	23	10	23
15,000	2.1	4.8	4.4	10	4.7	11	7.6	17	13	29	15	35
20,000	2.3	5.3	4.8	11	5.1	12	8.4	19	14	32	19	44
25,000	2.5	5.6	5.2	12	5.5	13	9.0	21	15	34	21	48
30,000	2.6	6.0	5.5	13	5.9	14	9.6	22	16	37	22	50
35,000	2.7	6.2	5.8	13	6.2	14	10	23	17	38	23	53
40,000	2.9	6.7	6.1	14	6.5	15	11	24	18	40	24	56
50,000	3.1	7.1	6.5	15	7.0	16	11	26	19	43	26	60
60,000	3.3	7.6	7.0	16	7.4	17	12	27	20	46	28	63
80,000	3.6	8.3	7.7	18	8.1	19	13	31	22	51	30	70
100,000	3.9	9.0	8.3	19	8.8	20	14	33	24	55	33	75
150,000	4.4	10	9.4	22	10	23	16	38	27	62	38	86
200,000	4.9	11	11	24	11	26	18	41	30	69	41	95

The primary responsibility of a capacitor fuse is to isolate a shorted capacitor before the capacitor can damage surrounding equipment or personnel. Typical capacitor failure occurs when the dielectric in the capacitor is no longer able to withstand the applied voltage. A low impedance current path results. The excessive heat generated builds pressure and can cause violent case rupture. A fuse will isolate the shorted capacitor before case rupture occurs.

FUSE PLACEMENT

The Code requires that an overcurrent device be placed in each ungrounded conductor of each capacitor bank (see Figure 1). The Code further requires that the rating or setting of the overcurrent device be as low as practicable. A separate overcurrent device is not required if the capacitor is connected on the load side of a motor-running overcurrent device.

Fusing per the Code provides reasonable protection if the capacitors are the metallized film self-healing type. If not, each capacitor should be individually fused as shown in Figure 2.

Fusing each individual capacitor is especially important in large banks of parallel capacitors. Should one capacitor fail, the parallel capacitors will discharge into the faulted capacitor and violent case rupture of the faulted capacitor can result. Individual capacitor fusing eliminates this problem.

If the capacitors are to be placed in banks comprised of both series and parallel combinations, the capacitor manufacturer must be consulted for fuse placement recommendations. The opening of improperly placed fuses can cause overvoltage and result in damage to other capacitors in the network.

AMPERE RATING

How much overcurrent can a capacitor withstand? What effects do neighboring capacitors have on the inrush of a given capacitor? These and other questions influence fuse selection. Circuit analysis can be very complex. It is best to consult the capacitor manufacturer for specific recommendations.

For applications 600V or less in lieu of specific fusing recommendations from the capacitor manufacturer, we suggest a Mersen A60C Type 121 or an A6Y Type 2SG fuse sized at 165% to 200% of the capacitor's current rating (contact factory for technical data). If these fuses are not dimensionally acceptable, then a non-time delay Class J or Class RK1 fuse could be used and sized at 185% to 220% of the capacitor's current rating.

For applications over 600V to 5.5kV, we suggest Amp-Trap A100C to A550C capacitor fuses. These medium voltage fuses are available in a variety of voltage ratings and mounting configurations. Refer to Section MV for specific data. Medium voltage capacitor fuses are sized at 165% to 200% of the capacitor current rating.

Capacitor fuses are selected for their ability to provide short circuit protection and to ride through capacitor inrush current. Inrush current is affected by the closing angle, capacitance, resistance and inductance of the circuit, and varies from one application to another. Inrush lasts for less than 1/4 cycle and is typically less than 25 times the capacitor's current rating.

Steady state capacitor current is proportional to the applied voltage and frequency. Since voltage and frequency are fixed in power factor correction applications, the capacitor is not expected to be subjected to an overload. Therefore, capacitor fuses are not selected to provide overload protectors for the capacitor.

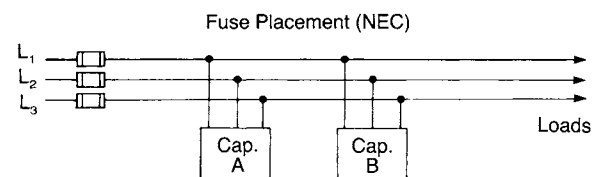

Figure 1

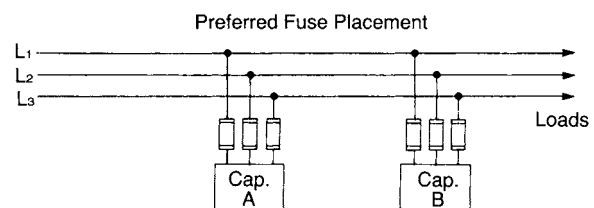

Figure 2

kVAR VS. AMPS

The capacitor's current rating can be derived from its kVAR rating by using the following formula:

$$\frac{\text{kVAR} \times 1000}{\text{volts}} = \text{amps}$$

1 kVAR = 1000VA (Reactive)

Example#1: What fuse would you recommend for a three phase capacitor rated 100kVAR at 480 volts?

$$\frac{100,000 \text{ volt-amps}}{480 \text{ volts}} = 208 \text{ amps}$$

To determine line current, we must divide the 208 amps, which is the three phase current by $\sqrt{3}$:

$$\frac{208}{\sqrt{3}} = 120 \text{ amps}$$

If an A6OC Type 121 fuse is to be used, size the fuse at 165% to 200% of line current.

$$120 \text{ amps} \times 1.65 = 198 \text{ amps}$$

$$120 \text{ amps} \times 2.00 = 240 \text{ amps}$$

Suggestions: A60C200-121 or A60C200-121TI

If a Class J or a Class RK1 is to be used, size the fuse at 185% to 220% of line current.

$$120 \text{ amps} \times 1.85 = 222 \text{ amps}$$

$$120 \text{ amps} \times 2.20 = 264 \text{ amps}$$

Suggestions: A4J225 or A6K225R

Example#2: What fuse would you recommend for a three phase capacitor rated 2.4kV, 100kVAR?

Calculate Capacitor Current =

$$\frac{100,000 \text{ volt-amps}}{\sqrt{3} \times 2400\text{V}} = 24\text{A}$$

$$\text{fuse size } 24 \times 1.65 = 39\text{A}$$

$$24 \times 2.00 = 48\text{A}$$

We suggest a 40 or 50 amp fuse rated at least 2400V A250C50-XX, where XX is the type of mounting needed.

USING CABLE PROTECTORS

Cable Protectors are special purpose limiters which are used to protect service entrance and distribution cable runs. The National Electrical Code (NEC) does not require using cable protectors.





When unprotected cables are paralleled, a single conductor faulting to ground can result in damage to and eventual loss of all parallel conductors. The resultant cost of cable replacement, loss of service, and down time can be significant. This cost can be minimized by the use of Cable Protectors.

When each phase consists of three or more parallel conductors, Cable Protectors are installed at each end of each conductor. Should one cable fault, the Cable Protectors at each end of the faulted cable will open and isolate the faulted cable. The unfaulted cables will maintain service.

TERMINATIONS

In addition to improving system reliability, Cable Protectors provide a means of terminating cable, thus eliminating the need for cable lugs. Cable Protectors are available with the following configurations:

Aluminum and copper cable require different terminations. Cable Protectors intended for copper cable must not be used with aluminum cable. Cable Protectors intended for aluminum cable include an oxide inhibitor.

Cable to cable		Type 1
Cable to offset bus		Type 3
Bus to offset bus		Type 5
Mole to cable		Type 6
Mole to offset bus		Type 8

PLACEMENT OF CABLE PROTECTORS

In single phase applications where a single transformer supplies the service and there are only one or two conductors per phase, a single Cable Protector per cable may be used. The Cable Protector should be located at the supply end of the cable. In all other applications, Cable Protectors

should be placed at both ends of each cable. This allows a faulted cable to be isolated from the source end and from a back feed at its load end. Isolation of a faulted cable is only possible if there are 3 or more parallel cables per phase.

CABLE PROTECTOR AMPACITY

Cable Protectors are not ampere rated. They are not intended to provide overload protection for the cable. Cable Protectors are designed to open in case of a short circuit or after a cable has faulted. Thus total system reliability is maximized. For these reasons Cable Protectors are rated in terms of the cable material (aluminum or copper) and the cable size (250kcmil, 500kcmil, etc.)

SELECTING A CABLE PROTECTOR

The following questions must be answered to choose the correct Cable Protector:

- Is the cable copper or aluminum?
- What is the cable size?
- What termination type is desired?
- Is the Cable Protector to be insulated or protected with a heat-shrink sleeve or a rubber boot?

Once these questions have been answered, the Cable Protector catalog number can be chosen from the listings.

SMALL CABLE SIZES

Class J fuses may be used for cable sizes smaller than 4/0. Since Class J blades are drilled for bolting, they may be attached directly to bus. Cables must be prepared by installing lugs before bolting to the fuse. Cable-to-bus or cable-to-cable terminations are possible. The following ampere ratings are recommended, or each cable size.

Cable - Size Awg CU or AL	Class J Fuse Catalog No.
#4	A4J125
#3	A4J150
#2	A4J175
#1	A4J200
1/0	A4J250
2/0	A4J300
3/0	A4J400

TYPICAL CONSTRUCTION OF A MOTOR STARTER

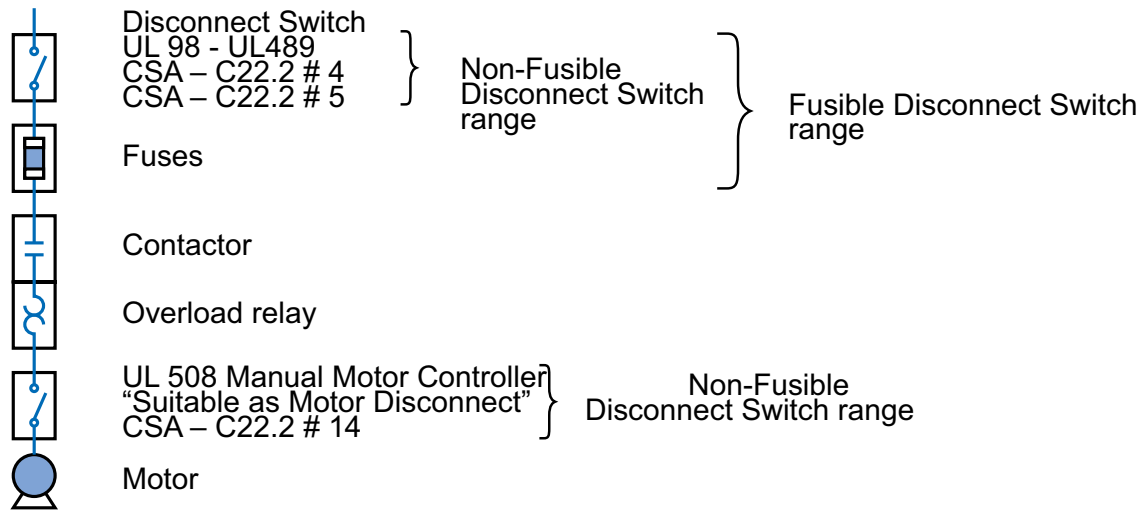

ESSENTIAL PARTS OF A MOTOR BRANCH CIRCUIT REQUIRED BY THE NATIONAL ELECTRICAL CODE:

- Disconnect means
- Branch-circuit short-circuit protective device
- Motor-controller
- Motor overload protective devices

DISCONNECT MEANS

The Disconnect means can be a Manual Disconnect Switch according to UL 98.

A manual Motor Controller (according to UL 508) additionally marked "Suitable as Motor Disconnect" is only permitted as a disconnecting means where installed between the final branch-circuit short-circuit and ground-fault protective device and the motor (NEC 2008 Article 430.109).

BRANCH-CIRCUIT SHORT-CIRCUIT PROTECTIVE DEVICE

The short-circuit protective device can be either a Fuse or an Inverse-time Circuit-breaker.

MOTOR-CONTROLLER

Any switch or device that is normally used to start and stop a motor according to the National Electrical Code article 430.82.

MOTOR OVERLOAD PROTECTIVE DEVICES

The National Electrical Code permits fuses to be used as the sole means of overload protection for motor branch circuits. This approach is often practical only with small single phase motors. Most integral horsepower 3 phase motors are controlled by a motor starter which includes an overload relay. Since the overload relay provides overload protection for the motor branch circuit, the fuses may be sized for short-circuit protection.

AUXILIARY CONTACT WIRING DIAGRAMS

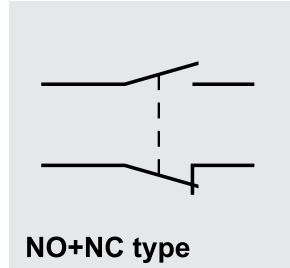
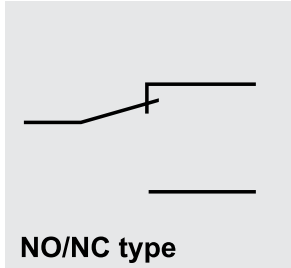

AUXILIARY CONTACT RATING CODES (ACCORDING TO UL508 STANDARD ITEM 139)

Designation

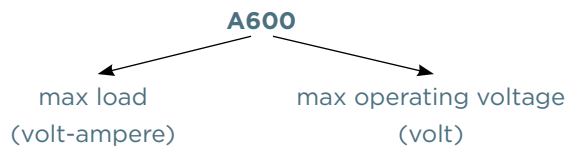

These codes concern the auxiliary contacts and give the maximum load they can make or break. The numerical suffix designates the maximum voltage design values, which are to be 600, 300, and 150 volts for suffixes 600, 300, and 150 respectively. The table below gives some typical rating codes:

Example

A contactor used at 600VAC - 60 Hz has the following specifications:

Average consumption: - inrush 60 Hz: 1200VA
- sealed 60 Hz: 120VA

Thus a C600 rated auxiliary device is the minimum rating required.

Contact Rating Code Designation	Max Operating Voltage [V]	Network Type	Making Max Load [VA]	Breaking Max Load [VA]
A600	600	AC	7200	720
B600	600	AC	3600	360
C600	600	AC	1800	180
D300	300	AC	432	72
E150	150	AC	216	36
N600	600	DC	275	275
P600	600	DC	138	138
Q600	600	DC	69	69
R300	300	DC	28	28

Note: A600 and N600 are the highest categories and may be used to cover all cases.

DEFINITION

Coordination is defined as properly localizing a fault condition to restrict outages to the equipment affected, accomplished by choice of selective fault protective devices.

Coordination (selectivity, discrimination) is desirable and often times mandatory. A lack of coordination can represent a hazard to people and equipment. When designing for coordination, fuses provide distinct advantages over other types of overcurrent protective devices.

To coordinate a circuit breaker protected system, it is generally necessary to intentionally delay the short circuit response of upstream breakers. Though coordination may be achieved, short circuit protection is compromised. The speed and consistency of response of fuses allows coordination without compromising component protection.

The terms coordination and selectivity are often used interchangeably. The term coordination should be used to describe a system as defined above, while

two fuses are said to be selective if the downstream fuse opens while the upstream fuse remains operable under ALL conditions of overcurrent. The term “discrimination” is synonymous with selectivity and is the preferred international term for this definition.

The word ALL is key. Fuse selectivity cannot be assured by comparing fuse time current curves alone. These curves stop at .01 second. Fuse performance under high fault conditions must also be evaluated. Fuse I²t is the best tool for assuring coordination under high fault current conditions. If the total clearing I²t of the downstream fuse is less than the melting I²t of the main upstream fuse, the fuses will be selective under high fault conditions.

To simplify presenting weighty I²t data, selectivity information can simply be found in selectivity ratio tables.

The ratios found in the following tables are conservative and are appropriate for all overcurrents up to 200,000 amperes RMS. In some cases smaller ratios than shown may be used. Consult your Mersen representative for specific recommendations.

FUSE SELECTIVITY RATIOS - 600 AND 480 VOLT APPLICATIONS UP TO 200,000 RMS SYMMETRICAL AMPERES

Branch Fuse	Ratio (For Fuses Rated 61 – 6000A) Main Fuse								
	A4BQ	A4BY	A4BT	TRS	A6K	A6D	A4J	AJT	A6T
A4BQ	2:1	2:1	2:1	-	-	-	-	-	-
A4BY	-	2.5:1	2:1	-	-	-	-	-	-
A4BT	2.5:1	2.5:1	2:1	-	-	-	-	-	-
TRS	4:1	4:1	3:1	2:1	4:1	4:1	4:1	3:1	4.5:1
A6K	2:1	2:1	1.5:1	1.5:1	2:1	2:1	3:1	2:1	3.5:1
A6D	2:1	2:1	1.5:1	1.5:1	2:1	2:1	3:1	2:1	3.5:1
A4J	2:1	2:1	1.5:1	1.5:1	2:1	2:1	2:1	2:1	3:1
AJT	2:1**	2:1**	2:1	1.5:1	2:1	2:1	2.5:1	2:1	3.5:1
A6T	3:1	2.5:1	2:1	1.5:1	2:1	2:1	2:1	2:1	2.5:1

FUSE SELECTIVITY RATIOS - 240 VOLT APPLICATIONS UP TO 200,000 RMS SYMMETRICAL AMPERES

Branch Fuse	Ratio (For Fuses Rated 61 – 6000A) Main Fuse								
	A4BQ	A4BY	A4BT	TR	A2K	A2D	A4J	AJT	A3T
A4BQ	2:1	2:1	2:1	-	-	-	-	-	-
A4BY	-	2.5:1	2:1	-	-	-	-	-	-
A4BT	2.5:1	2.5:1	2:1	-	-	-	-	-	-
TR	4:1	4:1	4:1	1.5:1	4:1	3:1	4:1	3:1	5:1
A2K	2:1	2:1	1.5:1	1.5:1	2:1	1.5:1	2:1	1.5:1	3:1
A2D	2.5:1	2.5:1	2:1	1.5:1	2:1	1.5:1	2:1	2:1	3:1
A4J	2:1	2:1	1.5:1	1.5:1	2:1	1.5:1	2:1	2:1	3:1
AJT	2:1	2:1	2:1	1.5:1	2.5:1	2:1	2.5:1	2:1	3:1
A3T	1.5:1	1.5:1	1.5:1	1.5:1	1.5:1	1.5:1	1.5:1	1.5:1	2:1

**Exception: For AJT450-600 use 2:1 on 480V only, 2.25:1 on 600V.

HOW MANY FUSES WILL OPEN ON A SHORT CIRCUIT?

In a three phase system typically only two fuses will open on a line-to-line short circuit. Since all three line currents are offset from each other (see chart to the right), each fuse will see the full fault at different times. Therefore the fuses will open at different times, once the first two fuses open, the circuit is disconnected and the third one typically never sees the full fault current. The third line can only conduct current directly to ground.

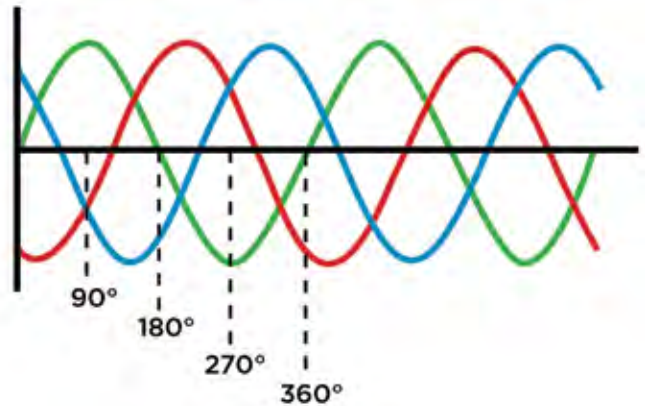

How many fuses will open on an overload?

Similar to a short circuit typically two fuses will open on an overload. Typically, one fuse opening will not be adequate to disconnect all three phases so the two remaining phases will conduct the overcurrent until one of them opens. At this point, the last fuse will only be able to conduct current directly to ground so it most likely will not open.

Is it ok to replace only the open fuses?

It is always recommended to replace all three fuses. In both short circuit and overload conditions the third fuse might not open but there is no way to tell how much of the element may have melted due to the overcurrent. Not replacing the third fuse can lead to issues in the future such as nuisance openings which can result in costly downtime.

Is there a life expectancy on my fuse?

A fuse does not have a “mean time between failures” because theoretically a fuse only needs to be replaced once it opens on an overcurrent. Fuses are 100% tested before leaving the factory to ensure that they will perform as intended. In the real world, factors such as temperature and humidity can cause a fuse to need replacement. Mersen suggests using ten years as a guideline for replacing both fuses installed and in inventory.



Fuses are 100% tested before leaving the factory to ensure they will perform as intended.

SHORT CIRCUIT RATING (SCCR)

The National Electric Code (2017) defines Short-Circuit Current Rating (article 100) as “the prospective symmetrical fault current at a normal voltage to which an apparatus or system is able to be connected without sustaining damage exceeding defined acceptance criteria.” SCCR is important to provide for safety of people and equipment during short-circuit conditions.

Article 409.110 (3) states that industrial control panels shall be marked with “short-circuit current rating of the industrial control panel based on one of the following: (a) short-circuit current rating of a listed and labeled assembly (b) short-circuit current rating established utilizing an approved method.” The fine print note refers to UL 508A, supplement SB as an example of an approved method. 430.8 require motor controllers to be marked with an SCCR.

Supplement SB in UL 508A uses a four step process to determine what a short circuit current rating for a panel should be. This process identifies the components with the lowest individual SCCR in the circuit. If there is no feeder over-current protective device (OCPD) this component is the weakest link and would determine the overall SCCR of the panel. Typically the feeder circuit will have an OCPD and we must consider its current-limiting effects on the circuit.

The feeder OCPD may limit fault currents enough so that the weakest link components are protected and the panel can have a higher overall SCCR. For more information please contact Mersen Technical Services at 978-462-6662 or technicalservices.nby@mersen.com.

11 REASONS FOR USING CURRENT-LIMITING FUSES:

Arc Flash Reduction: Current limiting fuses, when applied within their current limiting range, reduce personnel exposure to incident arc flash energy. Non fused systems may need extensive

re-engineering to reduce arc flash hazards, and improve personnel safety.

Safety: Overcurrent protective devices which operate are often reset without first investigating to find the cause of opening. Electromechanical devices which have opened high level faults may not have the reserve capacity to open a 2nd or 3rd fault safely. When a fuse opens it is replaced with a new fuse, thus protection is not degraded by previous faults.

Reliability: No moving parts to wear or become contaminated by dust, oil or corrosion.

Long Life: The speed of response of a fuse will not change or slow down as the fuse ages. In other words, the fuse’s ability to provide protection is not adversely affected by the passage of time.

Minimal Maintenance: Fuses do not require periodic recalibration as do electromechanical overcurrent protective devices.

Component Protection: The current limiting action of a fuse minimizes or eliminates component damage.

North American Standards: Tri-national Standards specify fuse performance and maximum allowable fuse I_p and I^2t let-thru values.

Selectivity: Fuses may be easily coordinated to provide selectivity under both overload and short circuit conditions.

High Interrupting Rating: You don’t pay a premium for high interrupting capacity.

Most low voltage current limiting fuses have a 200,000 ampere interrupting rating.

Cost Effective: Fuses are generally the most cost effective means of providing overcurrent protection. This is especially true where high fault currents exist or where small components need protection.

Extended Protection: Devices with low interrupting ratings are often rendered obsolete by service upgrades or increases in available fault current. Non-fused systems may need expensive system upgrades to maintain system safety.

THREE CLUES FOR DETECTING WHEN IS A FUSE TOO OLD FOR STOREROOM INVENTORY

Storeroom managers often have the responsibility for identifying obsolete inventory. There are advantages to having the right inventory for needs, without the clutter of fuses that should never be used. Obsolete fuses can mask stock-out of important spare fuses resulting in needless emergencies. Sometimes, an electrician will mistakenly use an obsolete fuse and create a dangerous safety condition.

What conditions would make a fuse obsolete? There is functional obsolescence, concealed damage obsolescence, and age obsolescence. Any of these conditions justify discarding a fuse. The electrical safety experts at Mersen offer the following three clues for determining when a fuse should be removed from storeroom inventory:

1. Functional Obsolescence

Functional obsolescence occurs when the fuse can't protect the equipment due to changes in the electrical system, or when the end-use equipment needing this particular fuse has been abandoned. Either way, the fuse will not help in restoring the equipment to service. If it's accidentally used by an electrician, it could create a hazardous situation.

An example of a functionally obsolete fuse is a One-Time with a safety rating of only 10kA IR. When the fuse was originally purchased, it could have had an adequate safety rating. Now the electrical system has changed and requires a safety rating of more than 10kA. If the fuse is installed without adequate IR as required by OSHA, it could explode or cause personal injury.

2. Concealed Damage

Obsolescence can be caused by concealed damage. An electrician normally only checks for fuse continuity to determine its suitability for continued service. But other concealed damage can occur in storage. The biggest threat to fuses in storage is moisture.

Once fuses absorb too much moisture, they lose their interrupting (safety) capacity. Even if they are dried out after the exposure, they are permanently damaged. In normal use they generate enough heat to keep themselves safe from absorbing moisture, but not in storage. The absorption of moisture permanently changes the structure of the filler packing around the fuse link and consequently decreases the safety capacity.

A common check for water damage is to check for wrinkling on the fuse's paper label. If the paper label is wrinkled, it indicates excessive moisture during storage. Also, any water stains on the fuse body or corrosion on the ends can indicate moisture damage.

Other concealed damage can occur when a fuse is used and returned to the storeroom. Any fuse that show scratches on the blades or ferrules was probably inserted into fuse clips and returned to inventory.

3. Fuses Over 10 Years Old

When fuses are more than 10 years old, the history of these fuses is uncertain. More than likely, they were exposed to moisture or damaging conditions sometime during the 10 years of storage. This would make them unsafe and unreliable for maintenance. Most manufacturers mark a date code on their fuses.

Summary

If storeroom fuses exhibit functional obsolescence, signs of moisture damage, or are more than 10 years old, they should be replaced. For a free fuse audit and inventory analysis, visit call 978-462-6662.

1.0 General

The electrical contractor shall furnish and install a complete set of fuses for all fusible equipment on the job as specified by the electrical drawings. Final tests and inspections shall be made prior to energizing the equipment. This shall include tightening all electrical connections and inspecting all ground conductors. Fuses shall be as follows:

2.0 Mains, Feeders and Branch Circuits

A. Circuits 601 to 6000 amperes shall be protected by current-limiting Mersen Amp-Trap 2000® Class L time-delay A4BQ fuses. Fuses shall be time-delay and shall hold 500% of rated current for a minimum of 4 seconds, clear 20 times rated current in .01 second or less and be UL Listed and CSA Certified with an interrupting rating of 200,000 amperes rms symmetrical.

B. Circuits 600 amperes or less shall be protected by current-limiting Mersen Amp-Trap 2000® Class RK1 time-delay A2D (250V) or A6D (600V) or Class J time-delay AJT fuses. Fuses shall hold 500% of rated current for a minimum of 10 seconds (30A, 250V Class RK1 case size shall be a minimum of 8 seconds) and shall be UL Listed and CSA Certified with an interrupting rating of 200,000 amperes rms symmetrical.

C. Motor Protection

All individual motor circuits shall be protected by Mersen Amp-Trap 2000® Class RK1, Class J or Class L time-delay fuses as follows:

Circuits up to 480A: Class RK1 - A2D (250V) or A6D(600V)
Class J - AJT

Circuits over 480A: Class L - A4BQ

Fuse sizes for motor protection shall be chosen from tables published by Mersen for the appropriate motor rating. Heavy load and maximum fuse ratings are also shown for applications where typical ratings are not sufficient for the starting current of the motor.

D. Motor Controllers

Motor controllers shall be protected from short circuits by Mersen Amp-Trap 2000® time-delay fuses. For Type 2 protection of motor

controllers, fuses shall be chosen in accordance with motor control manufacturers' published recommendations, based on Type 2 test results. The fuses shall be Class RK1 A2D (250V) or A6D (600V) or Class J AJT or Class CC ATDR (600V).

- E. Circuit breakers and circuit breaker panels shall be protected by Mersen Amp-Trap 2000® fuses Class RK1 (A2D or A6D), Class J (AJT) or Class L (A4BQ) chosen in accordance with tested UL Series-connected combinations published in the current yellow UL Recognized Component Directory.
- F. Supplementary lighting and control circuits in the connected combinations shown up to 600VAC and 24 amps shall be protected by Mersen Amp-Trap 2000® Class CC time-delay ATQR or ATDR fuses, sized according to the fixture manufacturers recommendations.

3.0 Spares

Spare fuses amounting to 10% (minimum three) of each type and rating shall be supplied by the electrical contractor. These shall be turned over to the owner upon project completion. Fuses shall be contained and cataloged within the appropriate number of spare fuse cabinets (no less than one). Spare fuse cabinets shall be equipped with a key lock handle, be dedicated for storage of spare fuses and shall be GSFC, as supplied by Mersen.

4.0 Execution

- A. Fuses shall not be installed until equipment is to be energized. All fuses shall be of the same manufacturer to assure selective coordination.
- B. As-installed drawings shall be submitted to the engineer after completion of the job.
- C. All fusible equipment rated 600 amperes or less shall be equipped with fuse clips to accept Class RK1 or Class J fuses as noted in the specifications.

5.0 Substitution

Fuse sizes and types indicated on drawings are based on Mersen Amp-Trap 2000® fuse current-limiting performance and selectivity ratios. Alternative submittals to furnish materials other than those specified, shall be submitted to the engineer in writing two weeks prior to bid date, along with a short circuit and selective coordination study.



Index

- PF: UL/CSA Listed Power Fuses
- MF: Midget, PC Mount & Miniature Fuses
- MV: Medium Voltage Fuses
- SP: Special Purpose
- FB: Fuse Blocks & Holders
- PD: Power Distribution Blocks
- DS: Disconnect Switches
- ES: Engineered Solutions
- AP: Application Information

P
F

M
F

M
V

S
P

F
B

P
D

D
S

E
S

A
P

P
F

M
F

M
V

S
P

F
B

P
D

D
S

E
S

A
P

1000V DC Size NH HPBB Open Style Fuse Blocks . . . FB 44

1000VDC HPJ Class J Open Style Fuse Holders . . . FB 40-41

11 Reasons for Using Current-Limiting Fuses AP 34

1MSC Modular Semiconductor Fuse Blocks FB 56

1SC Modular Semiconductor Fuse Blocks FB 56

250 Volt Class H Fuse Blocks FB 22-28

250 Volt Class K Fuse Blocks FB 22-28

250 Volt Class R Fuse Blocks FB 22-28

2CL 250V Cable Protectors SP 34-38

300 Volt Class T Fuse Blocks FB 29-33

480 Volt Class G Fuse Blocks FB 34-35

5X20QC1 Single Pole Fuse Blocks FB 61

600 Volt Class G Fuse Blocks FB 34-35

600 Volt Class H Fuse Blocks FB 22-28

600 Volt Class J Open Style Fuse Blocks FB 16-19

600 Volt Class K Fuse Blocks FB 22-28

600 Volt Class R Fuse Blocks FB 22-28

600 Volt Class T Fuse Blocks FB 29-33

600 Volt FEB/FEC/FEX/FEY In-Line
Fuse Holders FB 36-39

600 Volt Midget/Class CC Fuse Blocks FB 20-21

6X32QC1 Single Pole Fuse Blocks FB 61

703 Semiconductor Fuse Holders FB 57-58

750 Volt UltraSafe™ Fuse Holders FB 12-15

9F60 Series for Capacitor Protection MV 35-42

9F60 Series for Motor Protection MV 20-25

9F60 Series PT Fuses for
Potential Transformer Protection MV 31-34

9F60/9F62 Series for Transformer Protection MV 2-11

9F62 Bolt-In Series for Transformer Protection MV 12-15

A2K-R Class RK1 Fuses PF 10

A2Y Form 600 Fuses SP 37-38

A3T Class T Fuses PF 32

A4BQ Class L Fuses PF 2

A4BT Class L Fuses PF 6

A4BX Welder Protectors SP 36

A4BY Class L Fuses PF 4

A4J Class J Fuses PF 22

A60C Capacitor Fuses SP 35

A6D-R Class RK1 Fuses PF 8

A6D-R Class RK1 Fuses PF 8

A6K-R Class RK1 Fuses PF 10

A6T Class T Fuses PF 32

A6Y Form 600 Fuses SP 37-38

ACK Forklift Truck Fuses SP 24-25

ACL Forklift Truck Fuses SP 24-25

AF Automotive Fuses SP 21

AF2 Automotive Fuses SP 21

AF2H Automotive Fuses Holders SP 22-23

AF3 Automotive Fuses SP 21

AF3H Automotive Fuses Holders SP 22-23

AFH Automotive Fuse Holders SP 22-23

AG Class G Fuses PF 29

AJT Class J Fuses PF 16

AJT Class J Reducer Fuses PF 28

ALS Forklift Truck Fuses SP 24-25

Amp-Trap® Bolt-in Series for
Motor Protection MV 26-28

Amp-Trap® Bolt-In Series for
Transformer Protection MV 12-15

Amp-Trap® CL-14 Series for
Transformer Protection MV 16-19

Amp-Trap® CS-3 Series for
Transformer Protection MV 2-11

Amp-Trap® DIN-style Series for
Motor Protection MV 29-30

Amp-Trap® PT Fuses for Potential
Transformer Protection MV 31-34

Amp-Trap® Series for Capacitor Protection MV 35-42

Amp-Trap® Series for Motor Protection MV 20-25

Application Information AP

ATDR Class CC Fuses PF 24

ATM Fast-Acting Midget Fuses MF 3

ATMR Class CC Fuses PF 28

ATQ Time-Delay Midget Fuses MF 2

ATQR Class CC Fuses PF 26

Automotive Fuse Holders SP 22-23

Automotive Fuses SP 21

Automotive Fuses & Holders SP 21-23

Auxiliary Contacts Application Information AP 31

Battery Module Fuses SP 2-4

Battery Pack Fuses SP 5-14

Cable Protection Application Information AP 29

Cable Protectors SP 26-38

Canadian Fuses PF 34-37

Capacitor Protection MV 35-42

Capacitor Protection Application Information AP 27-28

Circuit Protection Accessories PF 38

CL-14 Fuses Clip-Lock Clips	FB 54	EV/Automotive Fuses	SP 2-25
CL-14 Series for Transformer Protection	MV 16-19	FEB 600 Volt In-Line Fuse Holders	FB 36-39
Class C Canadian Fuses.	PF 34	FEC 600 Volt In-Line Fuse Holders	FB 36-39
Class CC 600 Volt Fuse Blocks	FB 20-21	Ferrule Fuse Clips.	FB 72
Class CC Fuses	PF 24-28	FEX 600 Volt In-Line Fuse Holders	FB 36-39
Class G 480 & 600 Volt Fuse Blocks	FB 34-35	FEY 600 Volt In-Line Fuse Holders	FB 36-39
Class G Fuses.	PF 29	Finger-Safe / FSPDB Series	PD 2-3
Class H 250 & 600 Volt Fuse Blocks	FB 22-28	Finger-Safe Power Distribution Blocks	PD 2-3
Class H Canadian Fuses.	PF 36-37	Forklift Truck Fuses	SP 24-25
Class J Fuse Holders	FB 10-11	FSFE In-Line Fuse Holders	MF 24
Class J Fuses	PF 16-23	FSM Multi-Meter Fuse	MF 7
Class J HPJ 1000VDC Open Style Fuse Holders	FB 40-41	FSPDB Series Power Distribution Blocks.	PD 2-3
Class J Open Style Fuse Blocks.	FB 16-19	Fuse Blocks & Holders	FB
Class K 250 & 600 Volt Fuse Blocks.	FB 22-28	Fuse Construction & Operation	AP 4
Class K-5 Fuses	PF 30-31	Fuse Descriptions.	AP 4
Class L Fuses	PF 2-7	Fuse Let-Thru Current Tables.	AP 21-26
Class R 250 & 600 Volt Fuse Blocks.	FB 22-28	Fuse Obsolescence	AP 35
Class RK1 Fuses.	PF 8-11	Fuse Pullers/Clip Clamps	PF 38
Class RK5 Fuses	PF 12-15	Fused Coordination Panelboards	ES 2-3
Class T 300 & 600 Volt Fuse Blocks	FB 29-33	Fusible Disconnect Switches: UL 98	DS 10-14
Class T Fuses.	PF 32-33	Fusible Shunt Trip Switch	ES 4-6
CNL Forklift Truck Fuses.	SP 24-25	GAB Miniature Fuses	MF 21
CNN Forklift Truck Fuses	SP 24-25	GDG Glass Fuses.	MF 19
Covers/Clips	FB 69-72	GDG-V Glass Fuses.	MF 19
CP 600V Cable Protectors	SP 26-33	GDL Glass Fuses	MF 16
CRN Class H Canadian Fuses.	PF 37	GDL-V Glass Fuses	MF 16
CRS Class H Canadian Fuses	PF 37	GFN Indicating Time-Delay Midget Fuses.	MF 9
CS-3 Series for Transformer Protection	MV 2-11	GGA Glass Fuses.	MF 18
DC Fuses	SP 35-38	GGA-V Glass Fuses.	MF 18
DCT Special Purpose Midget Fuses	MF 6	GGC Glass Fuses.	MF 17
Dead Front Fuse Covers	FB 69-70	GGC-V Glass Fuses.	MF 17
Definitions	AP 2-3	GGM Glass Fuses	MF 17
DFC Dead Front Fuse Covers.	FB 69-70	GGM-V Glass Fuses	MF 17
DFC3LP Fuse Block Accessories.	FB 71	GGU Fast-Acting Midget Fuses	MF 8
DFC3M Fuse Block Accessories.	FB 71	GGX Glass Fuses.	MF 21
Disconnect Switches	DS	Glass Fuses	MF 15-26
DRM Fuse Block Accessories.	FB 71	GPM Series Panel Mount Fuse Holders	FB 62-68
Dual HP10M Fuses	SP 43	GSA Miniature Fuses	MF 15
Dual HP15M Fuses.	SP 46	GSA-V Miniature Fuses	MF 15
Electronic Fuses	MF 15-26	GSB Glass Fuses	MF 19
Electronic/Glass Fuses	MF 15-26	GSB-V Glass Fuses	MF 19
Enclosed Disconnect Switches	DS 19-23	GSC Miniature Fuses	MF 18
Engineered Solutions.	ES	GSC-V Miniature Fuses	MF 18



P
F

M
F

M
V

S
P

F
B

P
D

D
S

E
S

A
P

GSD Miniature FusesMF 20

GSD-V Miniature FusesMF 20

GSF Miniature FusesMF 20

GSF-V Miniature FusesMF 20

HelioProtection® FusesSP 39-60

HelioProtection® HP15FHM32 Fuse Holders for PV ...FB 43

How Many Fuses Will Open on a Short Circuit?AP 33

How to Read a Time Current CurveAP 5

HP10J PV Fuses.....SP 51

HP10M PV Fuses.....SP 41

HP10NH PV Fuses.....SP 55

HP12NH PV Fuses.....SP 57

HP15FHM32 HelioProtection® Fuse Holders for PV ...FB 43

HP15G PV FusesSP 47

HP15M PV FusesSP 44

HP15NH PV Fuses.....SP 59

HP6J PV Fuses.....SP 49

HP6M PV Fuses.....SP 39

HPBB 1000V DC Size NH Open Style Fuse Blocks ...FB 44

HPJ 1000VDC Class J Open Style Fuse Holders ..FB 40-41

HSJ Class J Fuses.....PF 20

Hybrid Xp Series Over Current Protecting Device. .SP 15-16

Hybrid Xs EV Series Over Current
Protecting Device.....SP 17-20

IEC Disconnect Switches: PV-RatedDS 15-18

In-Line Fuse HoldersMF 24-25

In-Line Fuses.....MF 25

In-Line Fuses and HoldersMF 24-25

Let-Thru Current & I²TAP 20-21

Low Voltage Motor Protection
Application InformationAP 6-10

Medium Voltage Fuse Holders and Clips.....FB 45-54

Medium Voltage FusesMV

MEV100 Battery Pack Fuses.....SP 12-14

MEV55 Battery Pack Fuses.....SP 5-8

MEV70 Battery Pack FusesSP 9-11

M-fuse Battery Module Fuses.....SP 2-4

Midget 600 Volt Fuse Blocks.....FB 20-21

Midget Fuses.....MF 2-10

Midget, PC Mount & Miniature FusesMF

Miniature Fuse BlocksFB 61

Miniature Fuses.....MF 15-26

Miniature/Panel Mount Fuse BlocksFB 61-68

Motor Protection.....MV 20-30

Motor Starter General InfoAP 30

MPDB DimensionsPD 12

MPDB Double-Wide Open-Style PDBs.....PD 11

MPDB Series Open-Style Power Distribution Blocks PD 4-13

MPDB62 (Mini) Open-Style PDBs.....PD 6

MPDB63 (Mini) Open-Style PDBs.....PD 6

MPDB66 (Intermediate) Open-Style PDBsPD 7-8

MPDB67 (Intermediate) Open-Style PDBsPD 7-8

MPDB68 (Large) Open-Style PDBs.....PD 9-10

MPDB69 (Large) Open-Style PDBsPD 9-10

MRF Radial Lead Micro FusesMF 23

MRT Radial Lead Micro FusesMF 23

Non-Fusible Disconnect Switches: UL 508DS 2-4

Non-Fusible Disconnect Switches: UL 98DS 5-9

NRN Class H Canadian Fuses.....PF 36

NRS Class H Canadian Fuses.....PF 36

Open Style Fuse Blocks.....FB 16-39

OT Class K-5 Fuses.....PF 30

OTM Fast-Acting Midget FusesMF 5

OTN Class K-5 FusesPF 30

OTS Class K-5 Fuses.....PF 30

P243 Fuse BlocksFB 55

P243/P266/P292 Fuse Blocks.....FB 55

P266 Fuse Blocks.....FB 55

P292 Fuse BlocksFB 55

Panel Mount Fuse HoldersFB 62-68

P-Block Fuse Blocks.....FB 55

PC Board Mount Fuse ClipsFB 72

PC Mount FusesMF 11

PCF Fast-Acting PC Mount Fuses.....MF 11

PCS Semiconductor PC Mount Fuses.....MF 11

PCT Time Delay PC Mount FusesMF 11

Photovoltaic Fuse HoldersFB 40-

Photovoltaic Fuses.....SP 39-60

Potential Transformer ProtectionMV 31-34

Power Distribution Blocks.....PD

PS20x127 Ferrule Fuse Holders and
No-Load DisconnectorsFB 59-60

PV Fuse Block: HPBB 1000V DC Size NH Open Style FB 44

PV Fuse Holder: HP15FHM32 HelioProtection®.....FB 43

PV Fuse Holder: US15M1HEL UltraSafe™FB 42

PV Fuses.....SP 39-60

PV-Rated IEC Disconnect Switches	DS 15-18	Transformer Protection: Primary/Secondary Fuses for LV Transformers	AP 12
PV-Rated UL Disconnect Switches	DS 15-18	TRM Time-Delay Midget Fuses	MF 4
Quick Three Phase Short Circuit Calculations	AP 33	TR-R Class RK5 Fuses	PF 12
Radial Lead Micro Fuses	MF 23	TRS-R Class RK5 Fuses	PF 12
SBS Fast-Acting Ferrule Fuses	MF 10	TRS-RDC Class RK5 Fuses	PF 14
Selectivity Between Fuses	AP 32	Type EK 9F61 Series Fuse Holders and Clips	FB 45-53
Semiconductor Fuse Blocks and Holders	FB 55-59	U705 Semiconductor Fuse Holders	FB 57-58
SFRB In-Line Fuse Holders	MF 24	U710 Semiconductor Fuse Holders	FB 57-58
SFRG In-Line Fuse Holders	MF 24	UL 508 Non-Fusible Disconnect Switches	DS 2-4
SFRT In-Line Fuse Holders	MF 24	UL 98 Fusible Disconnect Switches	DS 10-14
SFRU In-Line Fuse Holders	MF 24	UL 98 Non-Fusible Disconnect Switches	DS 5-9
Short Circuit Calculations	AP 33	UL Disconnect Switches: PV-Rated	DS 15-18
Short Circuit Rating (SCCR)	AP 34	UL/CSA Fuse Accessories	PF 38
SHR In-Line Fuses and Holders	MF 25	UL/CSA Listed Power Fuses	PF
SJ Series Open Style Fuse Blocks	FB 16-19	UltraSafe™ 750 Volt Fuse Holders	FB 12-15
SLR In-Line Fuses and Holders	MF 25	UltraSafe™ Class J Fuse Holders	FB 10-11
SMF In-Line Fuses and Holders	MF 25	UltraSafe™ Fuse Holders	FB 2-15
SMG Glass Fuses	MF 22	UltraSafe™ US15M1HEL Fuse Holders for PV	FB 42
SMG-V Glass Fuses	MF 22	US14 750 Volt UltraSafe™ Fuse Holders	FB 12-15
Special Purpose	SP	US15M1HEL UltraSafe™ Fuse Holders for PV	FB 42
Stainless Steel Enclosed Disconnect Switches	DS 19-23	US22 750 Volt UltraSafe™ Fuse Holders	FB 12-15
STG Glass Fuses	MF 22	US3J UltraSafe™ Fuse Holders	FB 10-11
STG-V Glass Fuses	MF 22	US6J UltraSafe™ Fuse Holders	FB 10-11
Suggested Fuse Specifications	AP 36	USBB Bus Bar System	FB 4-5
Three Clues for Detecting When is a Fuse Too Old for Storeroom Inventory	AP 35	USCC UltraSafe™ Fuse Holders	FB 2-3
Transformer Protection	MV 2-19	USFM UltraSafe™ Fuse Modules	FB 8-9
Transformer Protection Application Information	AP 11	USGCC UltraSafe™ Fuse Holders	FB 6-7
Transformer Protection: Control Transformers	AP 13	USGM UltraSafe™ Fuse Holders	FB 6-7
Transformer Protection: General	AP 11	USM UltraSafe™ Fuse Holders	FB 2-3
Transformer Protection: Low Voltage Primary Protection	AP 11	Xp Series Over Current Protecting Device	SP 15-16
Transformer Protection: MV Transformers	AP 14	Xs EV Series Over Current Protecting Device	SP 17-20

P
F
M
F
M
V
S
P
F
B
P
D
D
S
E
S
A
P

MERSEN'S COMMITMENT TO YOU



95%
of orders shipped
on time and accurately



95%
of lines ordered will ship
within 24 hours



90%
of custom products ship
within 20 business days

24/7
EMERGENCY OVERNIGHT DELIVERY AVAILABLE
365

Courier service

Next flight out



Stocked items ordered by
2pm ET ship same day



Technical support located
in your time zone



3,300 SKUs stocked and
ready to ship

MERSEN

FIND IT FAST AT EP.MERSEN.COM



MERSEN IS A GLOBAL EXPERT
IN ELECTRICAL POWER AND
ADVANCED MATERIALS

NORTH AMERICA

USA

Mersen USA
374 Merrimac Street
Newburyport, MA 01950
T : +1 978 462 6662

Mersen USA
Rochester-NY, Corp.
1500 Jefferson Rd
Rochester, NY 14623 USA
T : +1 585-784-2500

CANADA

Mersen Canada
6200 Kestrel Road
Mississauga, ON L5T 1Z1
T : +1 416 252 9371

EUROPE

FRANCE

Mersen France SB S.A.S.
15 rue Jacques de Vaucanson
F-69720 Saint-Bonnet-de-Mure
T : +33 4 72 22 66 11

Mersen France Angers S.A.S.
2-4 rue du Déry, 49480
Saint Sylvain D'Anjou , France
T : +33-2-41-96-15-40

ASIA

CHINA

Mersen Shanghai
No.55-A6. Shu Shan Road
Songjiang 201611 Shanghai
T : ++86 216 760 2388



EP.MERSEN.COM