

Fixed on beam

CURRENT COLLECTOR DEVICES (CCD)

CCD FOR STANDARD BOGIE



Current collector devices are used by Metro to collect the energy from the third rail to energize the Electrical Multiple Unit installed in the trailers.

Since 40 years, Mersen offer the largest range of Current Collector Devices of the market with almost 200 applications running every day all over the world.

The comprehensive range of CCD for Metro is designed for all kind of configurations, Regular steel wheel Metro, Pneumatic wheel Metro, Monorail and, Driverless metro applications.

They can operate under 750VDC and 1.500VDC retracted manually or using a pneumatic system.

In this catalog, all technologies can be customized to fit in the space envelope available on your bogie.

In case 3rd rail ramps are too short to design a CCD on the bogie frame, Mersen can propose a solution based on an additional beam fixed on the bogie axle which will hold the Current collector devices at the right place.

The adaptation of the position of the CCD can be done in height and depth vs the position of the 3rd rail.

This will limit the vertical movement of the CCD relative to the third rail.

Primary suspension of bogie will be excluded in the calculation of the CCD shoe stroke.

Some references for CCD installed on a beam:

Argentina metro (AR), Barcelona metro (ES), Bruxelles metro (BE),...

FEATURES & BENEFITS

- Proven technology since 40 years with more than 200 applications running every day
- CCD's dimensions and characteristics can be customized to your application
- Minimum weight, especially low dynamic mass
- Low noise level
- Extremely compact
- Cost effective, proven technologies and simple fixing
- Low cost maintenance

APPLICATIONS

- Third rail applications for Metro

STANDARDS

- IEC 61373



Fixed on beam

TECHNICAL DATA OVERVIEW

Speed/Characteristic	90 km/h
Working Temperature	-40°C / +25°C
Pressure of the Shoe	120N ±20%

DIMENSIONS

Beam illustration - Front dwg 1039840

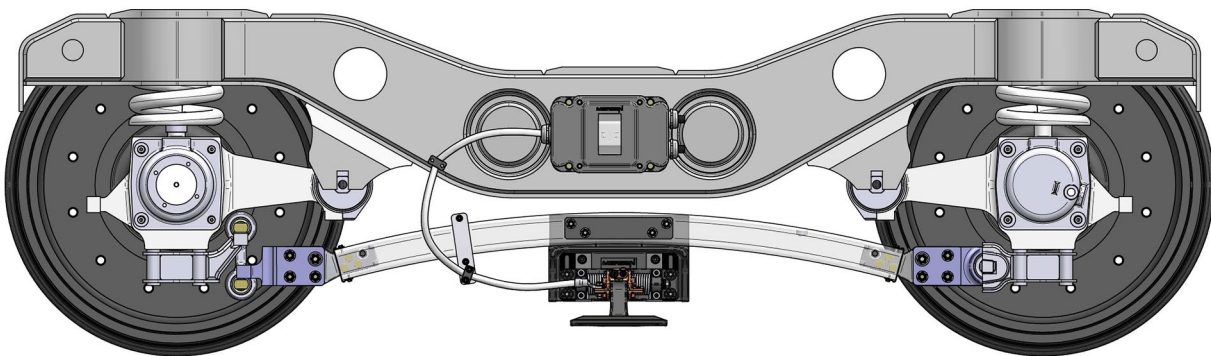

Beam illustration - 3D dwg 1041496

