

GROUND-FAULT ANALYSIS AND PROTECTION IN PV ARRAYS

Ye Zhao
Electrical Engineer

Robert Lyons Jr.
Product Manager

Points of Interest:

- Ground-fault is the most common fault in PV. If not properly protected, ground faults in PV arrays could result in large fault currents which may increase the risks of fire hazards
- The National Electric Code states that grounded (Article 690.5) and ungrounded (Article 690.35) PV arrays shall be provided with a ground-fault protection device to reduce fire hazards

1. Introduction

Ground-faults and ground-fault protection in solar photovoltaic (PV) arrays are discussed in this Tech Topic. Ground-faults in PV arrays could potentially result in large fault current which may increase the risk of fire hazards. To better understand ground-fault scenarios, a typical ground fault in a PV array is introduced, followed by PV current flows explanation and current vs. voltage (I-V) characteristics analysis. To protect PV arrays from damages due to ground-faults, the National Electrical Code (NEC) requires ground-fault protection devices (GFPD) in PV arrays. In most cases, the GFPD is a fuse rated at 0.5-1A within the PV inverter. Finally, the Tech Topic explains how to clear ground-faults by installing fuses and fuse protection characteristics.

2. Definition of Ground-Faults

A ground fault in photovoltaic (PV) arrays is an accidental electrical short circuit involving ground and one or more normally designated current-carrying conductors. Ground-faults in PV arrays often draw people's safety concerns because it may generate DC arcs at the fault point on the ground fault path. If the fault is not cleared properly, the DC arcs could sustain and cause a fire hazard.

3. Causes of Ground-Faults

Ground fault is the most common fault in PV and may be caused by the following reasons:

- Insulation failure of cables, i.e. a rodent animal chewing through cable insulation and causing a ground fault;
- Incidental short circuit between normal conductor and ground, i.e. a cable in a PV junction box contacting a grounded conductor incidentally;
- Ground-faults within PV modules, i.e. a solar cell short circuiting to grounded module frames due to deteriorating encapsulation, impact damage, or water corrosion in the PV module.

4. Typical PV Systems and Their Relationship with Ground-Fault NEC Requirements

A typical grid-connected PV system is schematically shown in Fig. 1. It mainly consists of a PV array, a grid-connected inverter, connection wirings and protection devices, such as overcurrent protection fuses and GFPDs. The PV array shown in Fig. 1 has n parallel PV strings, and each string has m modules in series.

Grounding

In the requirement of the NEC Article 690.41, there are two types of groundings in PV arrays. The first one is system grounding: the PV system with system voltage over 50 volts should be solidly system-grounded. To achieve that, the negative conductor usually is grounded via the GFPD in the PV inverter at point G (see Fig. 1). The other one is the equipment grounding: the exposed non-current-carrying metal parts of PV module frames, electrical equipment, and conductor enclosures should be grounded.

Normal Operating Condition

When the PV array is working under normal conditions, each PV string is generating current. The current flowing out of the i^{th} string is I_{i+} , where $i = 1 \dots n$. If PV strings are all electrically identical and have the same environmental working condition, then $I_{1+} = I_{2+} = \dots = I_{n+}$. The total current flowing out of the array is $I_{pv+} = I_{1+} + I_{2+} + \dots + I_{n+}$. Similarly, the current coming back to each string is $I_{1-}, I_{2-}, \dots, I_{n-}$. Thus, the total current coming back to the array is I_{pv-} , which should be equal to I_{pv+} . Since no external ground point is involved, the current flowing through the GFPD (I_g) should be zero. Notice that the PV array is supplying power, while the PV inverter absorbs the power and feeds it into the utility grid.

Kirchhoff's Current Law (KCL) requires that at any node (or junction) in an electrical circuit, the sum of currents flowing into that node is equal to the sum of currents flowing out of that node, where a node is any spot where two or more wires are joined. From this point of view, a ground-fault point, positive/negative bus bar, or even the inverter can be viewed as a node (or junction) in PV systems. Therefore, the current relationships of the normally operating PV arrays are summarized in the following equations.

- At the positive busbar: $I_{pv+} = I_{1+} + I_{2+} + \dots + I_{n+}$
- At the negative busbar: $I_{pv-} = I_{1-} + I_{2-} + \dots + I_{n-}$
- At the system grounding point G: $I_g = I_{pv-} - I_{pv+} = 0$
- At the inverter: $I_{pv+} = I_{pv-}$

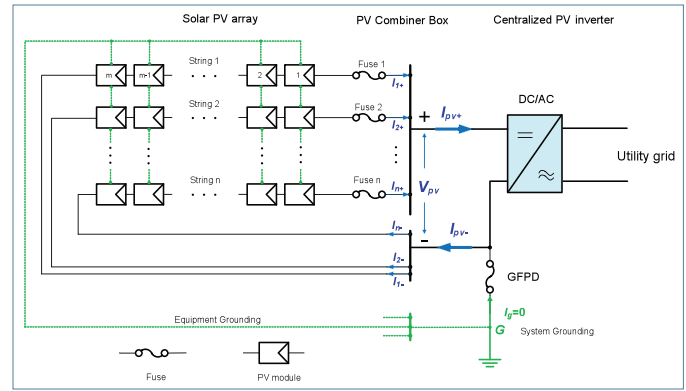

Figure 1: Schematic diagram of a typical grid-connected PV system under normal conditions

5. Ground Fault Analysis in PV Arrays

As shown in Fig. 2, a ground fault occurs in String 1 of the PV array. The reason might be a short circuit between the conductor of String 1 and the grounded module frame. Consequently, the fault will cause electrical imbalance among the PV array, resulting in mismatched currents.

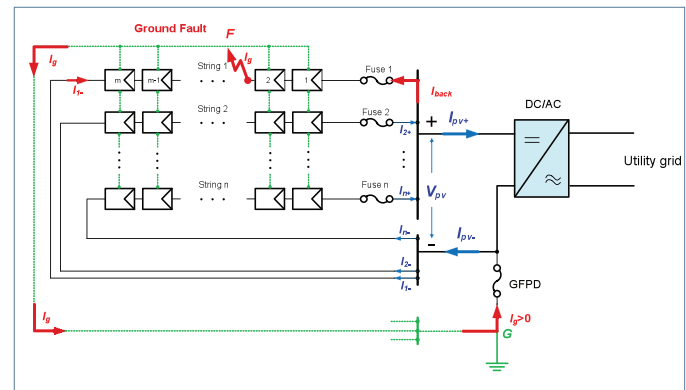

Figure 2: Schematic diagram of the PV system under a ground fault

Generally speaking, every module, string, and whole array, whether in normal or fault condition, has its own I-V characteristics and unique maximum power point (MPP). When PV modules are connected together, their performance is determined by the interactions among them. For this reason, PV modules perform together like a chain that is only as strong as the weakest link. In our case, the weakest link is the faulted String 1.

In our analysis, it is considered that the PV array is the only source of fault current. In other words, there is no overcurrent or overvoltage from any utility inverter, battery, lightning strikes or external sources. The reason is that most PV inverters are transformer-based that can provide galvanic isolation between the PV array and the utility grid. Also, the fault impedance is assumed to be zero.

2 — PVPN1: Ground-Fault Analysis and Protection in PV Arrays

Fault Current Flows

The fault changes the configuration of the PV array and causes subsequent fault currents. After the fault, String 1 only has two modules left operating, since the rest of modules (Module 3 ~ Module n) are short circuited by two ground points F and G . As a result, String 1 is significantly mismatched with other normal strings. Meanwhile, the operating voltage of the PV array might be even larger than the open-circuit voltage of faulted String 1. Therefore, instead of supplying power, String 1 may be forced to work as a load in the 4th quadrant of its I-V curve (see Fig. 3). Now String 1 has a negative current backfeeding from other normal strings. This current is often called backfed current (I_{back} or reverse current). I_{back} will flow into the fault point F and become a part of I_g . The other part of I_g is I_{1-} , which is the current coming from other $(n-2)$ modules in String 1. Since Module 3 ~ Module n in String 1 are short-circuited by ground points, I_{1-} will be equal to the short-circuit current of each PV module (I_{sc}) under standard test conditions. Finally, the backfed current (I_{back}) and the current from other modules (I_{1-}) will merge as the ground-fault current (I_g) at fault point F .

According to KCL, the current relationships of the ground-fault PV array are summarized as below.

- At the positive busbar: $I_{pv+} = -I_{back} + I_{2+} + \dots + I_{n+}$
- At the negative busbar: $I_{pv-} = I_{1-} + I_{2-} + \dots + I_{n-}$
- At the ground-fault point F : $I_g = I_{back} + I_{1-}$, where $I_{1-} = I_{sc}$
- At system grounding point G : $I_{pv+} + I_g = -$

I-V Characteristics Analysis under Ground-Fault Condition

In the worst case of a ground fault, the ground fault current could reach as high as $n I_{sc}$. In this scenario, the other $(n-1)$ normal strings have approximate total current $(n-1) I_{sc}$ backfeeding into String 1. Meanwhile, the modules below the ground fault point F in String 1 are flowing I_{sc} into F .

The fault scenario could be explained with the help of I-V characteristics analysis in Fig. 3, in which V_{oc} is the open-circuit voltage of one PV module. Before the fault, the PV array is working at MPP with operating voltage V_{mpp} and operating current I_{mpp} . At the moment of the ground fault, the PV array's configuration and I-V characteristics are changed suddenly. Meanwhile, the operating voltage at V_{mpp} is dropping to V_F immediately. Since V_F is the open-circuit voltage of the faulted array, the array becomes open-circuit and there is no current feeding into the PV inverter.

However, the current of each string inside the PV array is not zero. For $(n-1)$ normal strings, their operating point is at $(V_F,$

$I_{other})$. Notice that the operating voltage V_F is close to the knee of their I-V characteristics. Therefore, each string is providing the current close to I_{sc} . In other words, I_{other} is close to $(n-1) I_{sc}$. I_{other} has no path to go but to backfeed into String 1. As a result, I_{back} at String 1 becomes $(n-1) I_{sc}$, flowing into the ground-fault point F .

In summary, the worst-case current relationships of the PV array under a ground-fault can be re-written in the following equations.

- At the positive busbar: $I_{pv+} = -I_{back} + (n-1) I_{sc} = 0$
- At the negative busbar: $I_{pv-} = n I_{sc}$
- At the ground-fault point F : $I_g = n I_{sc}$

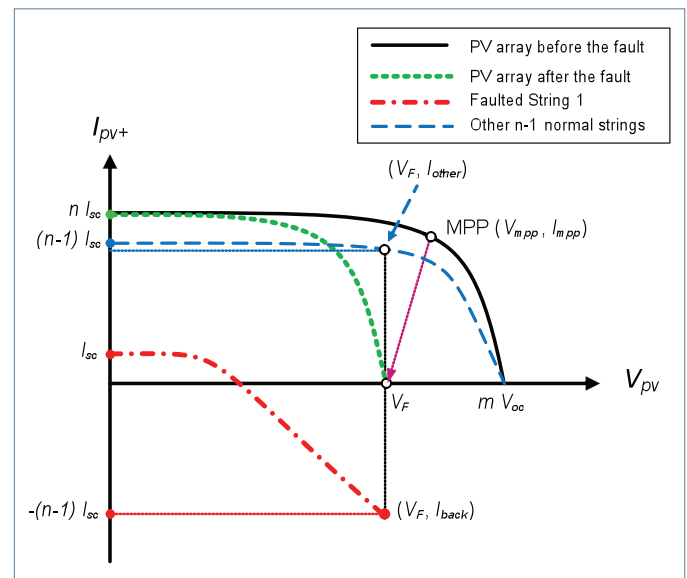

Figure 3: I-V characteristics of the PV array during a ground fault

Ground-Fault Current and Beckfed Current

Assume that in our case, for instance, the rated current of the GFPD (fuse) is 1A, there are 5 parallel strings in the PV array ($n=5$), and I_{sc} of each module is 5A. Simple calculation by the equations above will give us $I_g=25A$ in the worst case. According to the melting time vs. current diagram in Fig. 4 (next page), the 1A fuse takes less than 0.01s to clear the ground fault. In this instance, the fault path is detected by the fuse and the fault is interrupted successfully.

According to the NEC Article 690.5, if a grounded conductor is opened to interrupt the ground-fault current path, the grid-connected PV inverter fed by the faulted PV array shall automatically cease to supply power to the grid. Meanwhile, an indication of the fault should be provided. After the shutdown of the PV inverter, the whole PV array goes into the open-circuit condition, waiting for maintenance personnel to fix the problem.

3 — PVPN1: Ground-Fault Analysis and Protection in PV Arrays

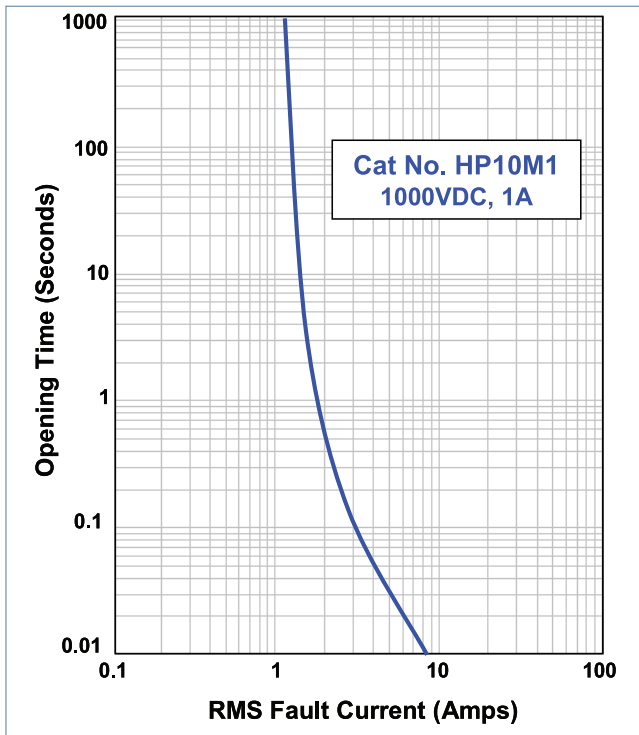

Figure 4: Melting time vs. fault current of protection fuses

6. Product Specific

For all applications abiding by the National Electric Code it is required that ground-fault overcurrent protection be installed and that if a ground-fault is detected, the inverter must be removed from operation in order to prevent electrical fire. Mersen offers a variety of fuse technologies designed to protect solar PV systems from ground-fault incidents and they are shown here for reference. More information may be obtained by visiting us-ferrazshawmut.mersen.com and searching for the products described below.

Fuses for ground-fault protection only

Mersen recommends PV rated Midget Class fuses (10 x 38mm, 1-1/2" x 13/32") for all ground-fault protection circuits. PV rated Midget Class fuses offer the highest degree of protection in the smallest physical package available. For 600VDC applications select the HP6M series and for 1000VDC applications select the HP10M series.

Two types of fuse holders are available for both the HP6M and HP10M series PV rated Midget Class fuses. For internal to the inverter cabinet, select the touch-safe, DIN rail mountable USM series fuse holder. For door-mount or panel-mount options select the touch-safe GPM series fuse holder. Both fuse holder options are suitable for applications 1000VDC or less and offer



tool-free fuse installation and change-outs.

Fuses for ground-fault protection and remote indication or signaling

Mersen recommends gRB type pin-indicating DC fuses for all ground-fault protection circuits that require mechanical indication or signaling for direct inverter communications. The mechanical signal can be used to indicate to the inverter control circuit that a ground-fault has occurred and shutdown is required.

For 600VDC applications, Type gRB 27x60mm fuses are recommended and should be used with the touch-safe, DIN rail mountable US27 series fuse holder. For 1000VDC applications, Type gRB 20x127mm fuses are recommended and should be used with the touch-safe, PS series fuse holder.



7. Summary

Improperly detected and interrupted ground-faults can present the risk of fire hazards in solar PV arrays. Excess current flow, including reverse current from adjacent strings, to faulted strings can overload conductors and/or connectors leading to overheating and risk of fire. Faulted strings can also negatively impact maximum power point tracking, ultimately affecting the efficiency and power output of the PV array. To properly protect PV arrays from damage, National Electric Code Article 690.5(A) specifies that the GFPD or system must be capable of detecting a ground-fault current, interrupting the flow of fault current and providing an indication of the fault. Mersen offers a variety of solutions and technical expertise to protect against ground-fault incidents in PV arrays. For more information visit us-ferrazshawmut.mersen.com.