

Evaluating Selective Coordination Between Current-Limiting Fuses And Non Current-Limiting Circuit Breakers

Steve Hansen
Senior Field Engineer

Robert Lyons Jr.
Product Manager

Special points of interest:

Overview of NEC articles where Selective Coordination is required

How fuses & circuit breakers operate

How to read time-current curves & peak let-through graphs

Two combinations & methods for evaluating selectivity

Introduction

System downtime is reduced when overcurrent protective devices are selectively coordinated. Designers should strive to limit the outage to only that circuit which is overloaded or which has faulted in order to avoid shutting down healthy parts of the electrical distribution system. Selectivity between overcurrent protective devices is generally desirable and may be mandatory.

Traditional time-current curve analysis may not accurately portray the degree of selectivity existing when current-limiting overcurrent protective devices are involved [2]. This Tech Topics will discuss viable methods for evaluating selectivity between current-limiting fuses and non current-limiting circuit breakers.

What is Selective Coordination?

The following definition is found in Article 100 of the 2008 National Electric Code®, “Coordination (Selective). Localization of an overcurrent condition to restrict outages to the circuit or equipment affected, accomplished by the choice of overcurrent protective devices and their ratings or settings.”

A branch circuit overcurrent protective device and its upstream feeder overcurrent protective device are selectively coordinated if any possible overcurrent passing through the branch device is cleared by the branch circuit device before the upstream feeder overcurrent device opens. Figure 1 illustrates the concept.

F1 is our main fuse. F2 represents our feeder fuse and F3 is the branch circuit fuse. When a fault occurs within any portion of the F3 branch circuit, the short circuit current will pass through F1, F2, and F3. If our system is selectively coordinated, F3 will clear the fault before either F2 or F1 opens. If our system is not selectively coordinated, F2 and perhaps F1 may open as well as F3, unnecessarily de-energizing portions of the distribution system.

National Electric Code® (NEC) Requirements

Selective Coordination is mandated by the National Electric Code® for critical applications to minimize electrical hazards to personnel and to ensure continuity of power in areas where power is essential for safety. Specific applications include people movers, emergency and standby power systems and critical operations power systems relating to national security, the economy and public health or safety.

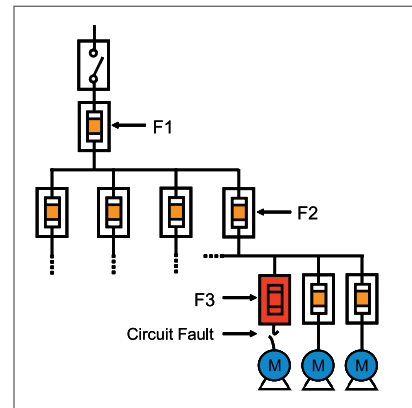

Figure 1 – Illustration of Selectively Coordinated System

The following NEC articles require selective coordination.

- NEC Article 517 – Healthcare Facilities
- NEC Article 620 – Elevators, Dumbwaiters, Escalators, Moving Walks, Platform Lifts and Stairway Chairlifts
- NEC Article 700 – Emergency Systems
- NEC Article 701 – Legally Required Standby Systems
- NEC Article 708 – Critical Operation Power Systems (COPS)

Background Information

When non current-limiting circuit breakers are downstream from current-limiting fuses, traditional time-current curve comparisons are appropriate for evaluating selectivity. However, a more detailed evaluation is necessary when current-limiting fuses are downstream from non current-limiting circuit breakers. An understanding of how fuses and circuit breakers operate is a prerequisite to understanding why different evaluation approaches are needed.

Fuse Operation

UL defines a current-limiting fuse as “A fuse that, within a specified overcurrent range limits the clearing time at rated voltage to an interval equal to or less than the first major or symmetrical current loop duration, and limits the peak current to a value less than the available peak current.”

[1] UL defines threshold current as “The lowest prospective symmetrical current above which a fuse is current-limiting.” [1]

Figure 2 illustrates a current-limiting fuse interrupting a single phase fault. The purple waveform represents one cycle of normal current followed by one cycle of prospective fault current. The blue triangular shaped waveform represents the actual current passed by the fuse as it clears the fault. The highest instantaneous current passed by the fuse is referred to as the fuse peak let-through current and is also known as I_p . The rate of current rise (di/dt) during the first few milliseconds of the fault is the primary external factor effecting fuse I_p . Thus as the prospective fault current increases so does the I_p for a given fuse.

The lower the fuse I_p at a given fault current level, the more current-limiting the fuse.

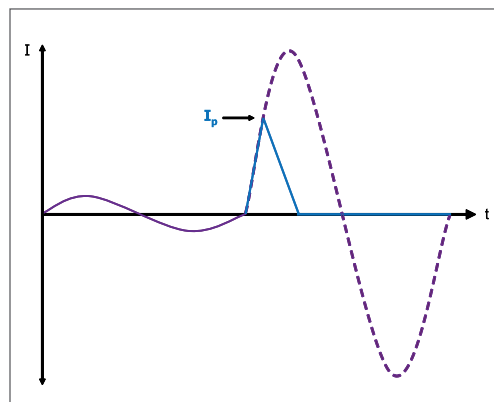

Figure 2 – Graphical Representation of Fuse Current-Limiting Ability

Fuse clearing times exceed $\frac{1}{2}$ cycle for fault currents below the fuse threshold. Under these conditions, I_p is expected to be between $1.414 \times I_{RMS}$ and $2.3 \times I_{RMS}$ where I_{RMS} represents the available symmetrical fault current. The actual value of I_p depends upon the power factor of the circuit and the degree of asymmetry of the waveform. If we assume I_p to be $2.3 \times I_{RMS}$ for currents below threshold, our assumption will be conservative, i.e., actual I_p will be less than assumed.

Circuit Breaker Operation

Similar to a fuse, a circuit breaker is a device designed to open an electrical power circuit, under specified abnormal overcurrent conditions, such as those of short circuit, with the purpose to protect people and equipment and their surrounding environments. Unlike a fuse, which relies on a calibrated thermal element to melt and disconnect power, circuit breakers contain one or more sets of contacts capable of making, carrying and breaking circuit currents. Low voltage power circuit breakers commonly utilize automatic switch technology powered by one of two technologies: electromagnetism or electronic trip mechanism.

“An understanding of how fuses and circuit breakers operate is a prerequisite to understanding why different evaluation approaches are needed.”

Typical molded case circuit breakers rely on an electromagnetic force, powered by circuit current, to force apart the contacts. During normal operating conditions mechanical spring forces hold the contacts closed. As circuit current increases an electromagnetic force is created, via a solenoid or coil, opposing the mechanical spring forces holding the contacts closed. As currents reach the maximum instantaneous pickup setting of the circuit breaker the forces become powerful enough to overcome the spring forces and separate the contacts.

Also unlike fuses, circuit breakers are not filled with an arc extinguishing substance such as silica sand. As the contacts are being driven apart an electrical arc is formed through air. Insulating barriers leading to arc chutes are commonly used to extinguish arcs in molded case circuit breakers. These mechanical differences can be seen in Figure 3.

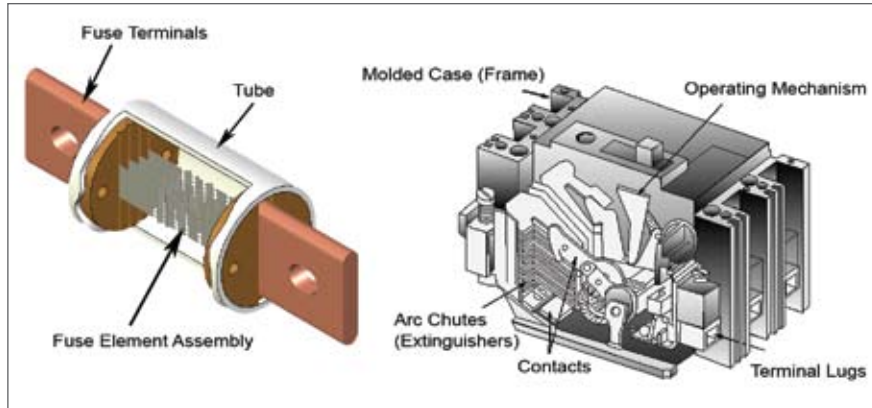

Figure 3 – Current-Limiting Fuse and Molded Case Circuit Breaker Construction

“When evaluating selectivity between non current-limiting circuit breakers and other overcurrent protection devices conventional time-current curves are necessary.”

Both mechanical and electronic trip circuit breakers are sensitive to the instantaneous peak current delivered during the fault [2]. Time is significant for magnetic trip functionality, the trip current must be present long enough to generate the force required to overcome the spring latched operating mechanism. Electronic trips operate similarly in that they may require several samples of the peak current values to check against the defined threshold trip value. If one or more values above the threshold trip value are registered, the circuit breaker will trip. A high sample count or built-in filters are often used to prevent nuisance trips due to transient conditions.

Figure 4 is an example of a time-current curve for an unspecified molded case circuit breaker. The upper portion of the curve represents the overload region of the circuit breaker, which is sometimes referred to as the long-time and short-time pick-up regions. The lower, horizontal portion of the curve represents the instantaneous portion, or short circuit region. The lower vertical band corresponds to the current values where the instantaneous trip function begins to operate. When evaluating selectivity between non current-limiting circuit breakers and other overcurrent protection devices conventional time-current curves are necessary.

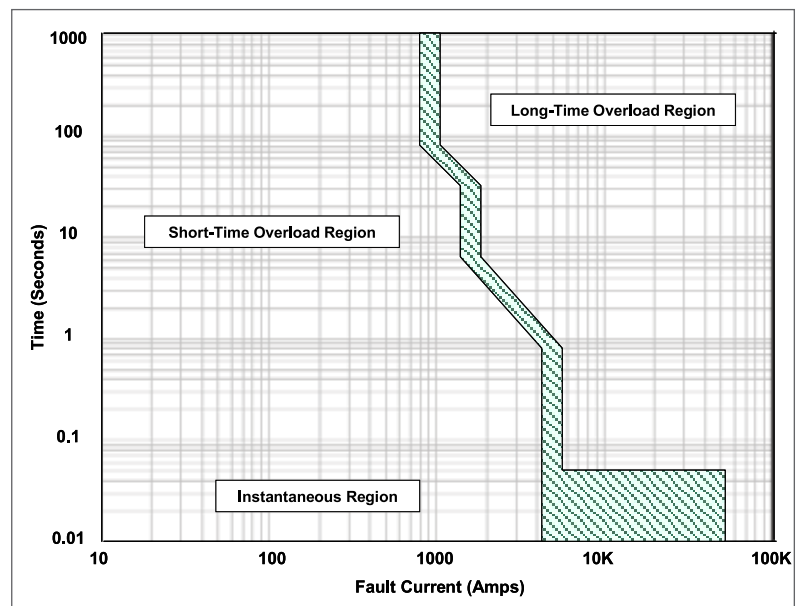

Figure 4 – Example of Circuit Breaker Time-current Curve

Time versus Current Curves and Peak Let-Through Current Curves

Fuse peak let-through current curves are generally available for UL Class fuses. Figure 5 is representative of the format generally followed by fuse manufacturers.

This graph contains I_p curves for top of the class ratings for a time-delay Class J fuse. Note the x and y-axis are logarithmic. The x-axis represents the prospective fault current in RMS symmetrical amperes (shown as kilo-amperes). The y-axis units are instantaneous amperes (shown as kilo-amperes). The graph contains a diagonal line labeled

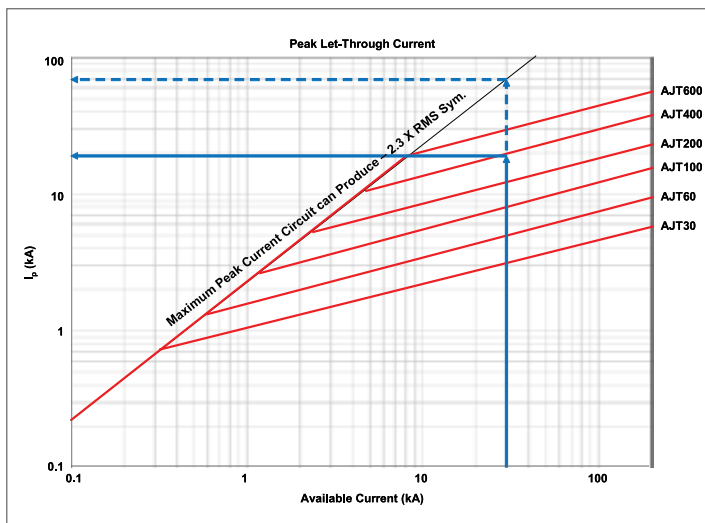

Figure 5 – Fuse Peak Let-Through Current Graph

“Maximum Peak Current Circuit Can Produce – 2.3 X RMS Sym.” This line gives the maximum instantaneous peak current possible assuming a waveform with maximum asymmetry in a circuit with a power factor of 15%. In theory the maximum instantaneous current can range from 1.414 X RMS to 2.828 X RMS. The 2.3 factor is chosen as a practical limit for low voltage circuits.

To determine the I_p for a given fuse, enter the x-axis at the calculated bolted fault current value. Proceed vertically to the fuse characteristic line. Then proceed horizontally and read the I_p value from the y-axis. Let’s consider an example. Assume the bolted fault current has been calculated to be 30kA. To determine the I_p for an AJT400 fuse, enter the x-axis at 30kA (solid blue line) and follow it to the characteristic line for the AJT400. From this point we move horizontally to the y-axis and read an I_p of 20kA. The dashed blue line tells us the circuit is capable of producing a peak instantaneous current of as much as 70kA.

Peak let-through graphs typically show only top of the class ratings. In figure 5 those ratings are 30A, 60A, 100A, 200A, 400A, and 600A. For fuse ratings of at least 30A it is possible to closely approximate I_p for an intermediate rating using the following formula.

$$I_{pb} = I_{pa} \left(\frac{\text{Rating B}}{\text{Rating A}} \right)^{2/3}$$

Where:

- I_{pa} is peak let-through current of the top of the frame at a given available current.
- I_{pb} is the peak let-through current of an intermediate rating at the same available fault current.

Example: What is the peak letthrough current for an AJT300 with an available bolted fault current of 30kA?

From Figure 5 – AJT400 → $I_{pa} = 20\text{kA}$

AJT300 → $I_{pb} = 20\text{kA} (300/400)^{2/3} = 16.5\text{kA}$

“Peak let-through graphs typically show only top of the class ratings.”

Fuse manufacturers publish three different types of time-current curves. They include minimum melting curves, average melting curves, and total clearing curves. Generally, all three curves would be plotted on separate graphs. For this explanation all three are shown together in Figure 6. Average melting curves are the most common, describing nominal product performance, shown as the dotted black line.

All manufactured products, fuses included, have production tolerances. These tolerances affect fuse performance. Figure 6 also shows a minimum melting curve (in purple) and a total clearing curve (in blue) for a 400A Class J fuse.

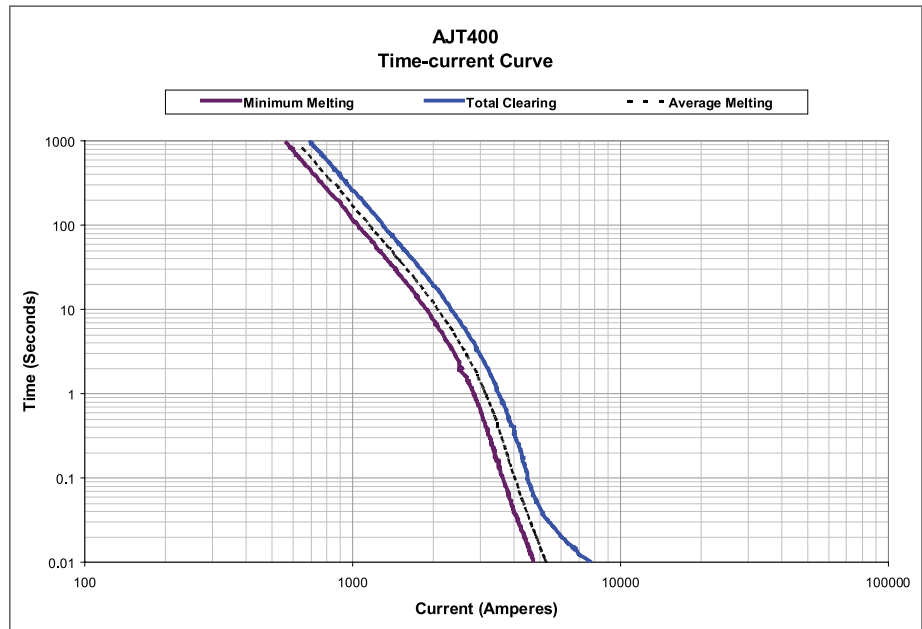

Figure 6 – Fuse Time-current Curves

The minimum melting curve represents the minimum time in which a fuse element will melt at a given RMS current. The total clearing curve represents the maximum melting time plus the arcing time at a given RMS current.

Minimum melting and total clearing curves are used to evaluate selectivity between overcurrent protective devices. If the total clearing curve for the branch circuit fuse does not cross or touch the minimum melting curve for the feeder circuit fuse, the devices are expected to be selective over the range of current and time shown on the time-current curves.

Average melting curves can be used for selectivity evaluation but the manufacturer should be consulted to determine the degree of separation that needs to be maintained to ensure selectivity.

Methods for Evaluating Selectivity

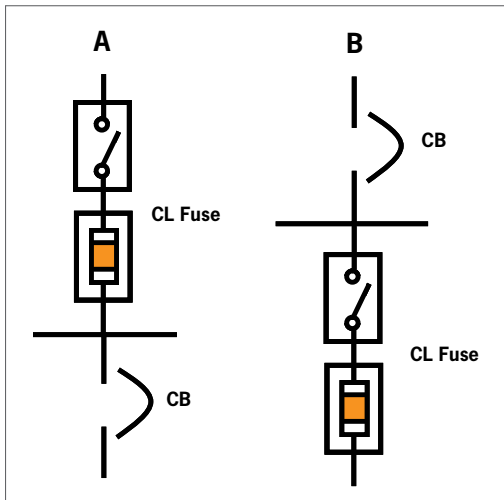

Figure 7 – Application A and B

Manufacturer-provided fuse selectivity ratios may be applied when evaluating selectivity between current-limiting fuses. However, it may not be practical to design an all fuse system. The strategic combination of fuses and circuit breakers within the same power system may provide the best overall design. In this paper we will examine two applications where fuses and circuit breakers are used in the same circuit and identify methods for evaluating selectivity. Application A involves current-limiting fuses upstream from non current-limiting circuit breakers. Application B involves non current-limiting circuit breakers upstream from current-limiting fuses. Both applications are shown graphically in Figure 7.

“Minimum melting and total clearing curves are used to evaluate selectivity between overcurrent protective devices.”

Current-Limiting Fuse above Non Current-Limiting Circuit Breaker (Application A)

For this combination of devices, traditional time-current curves may be used as the analytical tool to evaluate selectivity. As discussed previously, time-current curves are typically displayed as a band, the left most edge displaying the minimum melting time (for breakers, the pick-up characteristic) and the right most edge displaying the total clearing time. Figure 8 shows an example of devices

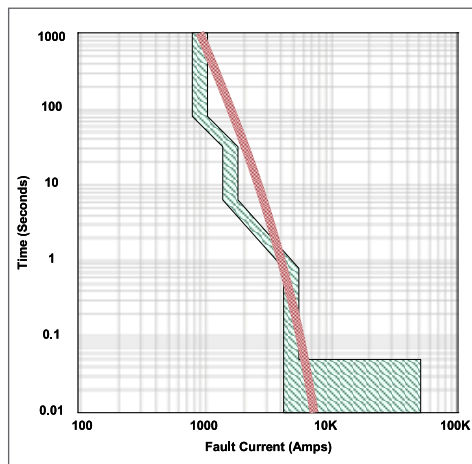

Figure 8 – Devices are not Selectively Coordinated

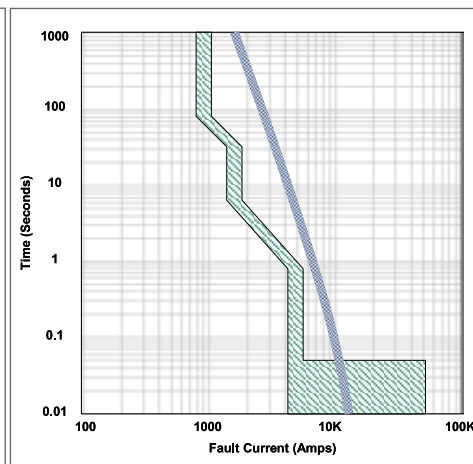

Figure 9 – Selectively Coordinated to 10kA

that are not selectively coordinated and Figure 9 shows devices that are selectively coordinated for fault currents not exceeding 10,000A.

When practicing this method identify a value of fault current along the x-axis. Follow this point vertically until it intersects the first curve, which will be the first device to trip. Continue vertically until you intersect the second curve, which is the next device that will trip. If a point is discovered where an upstream overcurrent protection device opens before the downstream overcurrent protective device clears, the system is not selectively coordinated.

Non Current-Limiting Circuit Breaker above Current-Limiting Fuse (Application B)

Traditional time-current curve analysis is appropriate for evaluating selectivity in the long-time and short-time portions [2] of the circuit breaker time-current curve. However, traditional time-current curve analysis may not accurately predict selectivity for instantaneous circuit breaker tripping.

Circuit breakers employing magnetic trips respond to instantaneous current. If the instantaneous current sensed exceeds the trip setting, the breaker commits to tripping and the unlatching process is initiated. Once unlatching is initiated the breaker will open. The same can be said for breakers employing simple digital electronic trips. When such a breaker senses an instantaneous current above its trip setting, the breaker commits to tripping and the unlatching process is initiated.

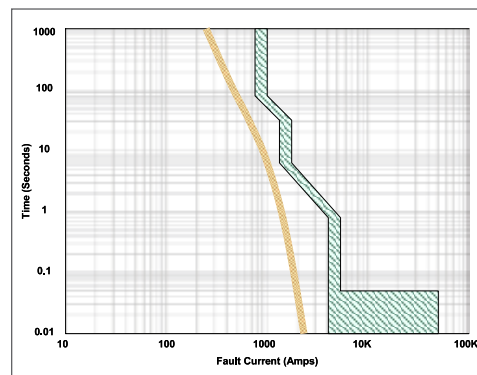

Figure 10 – Circuit Breaker Upstream of Fuse

“Traditional time-current curve analysis may not accurately predict selectivity for instantaneous circuit breaker tripping.”

Though circuit breakers are peak current sensing, the trip settings [2] are calibrated in RMS current. The ratio of peak to RMS for this calibration is 1.414 to 1. This ratio is derived from the ratio between peak and RMS current for a symmetrical sine wave. Thus a 1000A circuit breaker with a 10X instantaneous trip setting will commit to unlatching if it senses an instantaneous current (a peak current) exceeding $1000A \times 10 \times 1.414$ or 14,141A.

In order to evaluate selectivity between a down stream current-limiting fuse and an upstream peak sensing circuit breaker [3] when instantaneous tripping is possible, one needs to compare fuse I_p to the circuit breaker peak current trip setting. If the fuse I_p is less than the circuit breaker peak current trip setting, the devices will be selective in the circuit breaker instantaneous trip range.

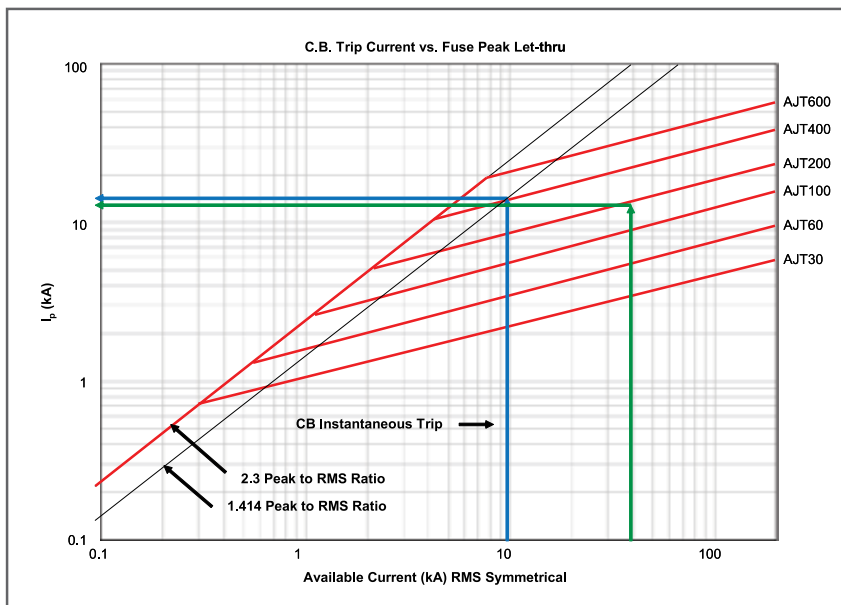

Figure 11 – Evaluating selectivity between a down stream current-limiting fuse and an upstream circuit breaker

Figure 11 represents an AJT200 fuse downstream from a 1000A circuit breaker with a 10x instantaneous trip setting. A diagonal line with a slope of 1.414 to 1 has been added to the fuse peak let-through current graph to facilitate conversion of the circuit breaker RMS calibrated trip setting into a peak current value. Figure 11 shows that an AJT200 fuse will pass an I_p that is less than the circuit breaker trip setting provided the prospective current doesn't exceed 40,000A.

Conclusion

Selective coordination reduces the likelihood of an unnecessary power outage and hence increases the reliability of the power delivery system. Though it is generally easy to achieve selective coordination in an all fuse system, such a system may not be practical. Current-limiting fuses placed in strategic circuits and selectively coordinated with circuit breakers may provide the best overall system design.

The two methods described in this paper allow one to evaluate selectivity between current-limiting fuses and non current-limiting circuit breakers. Fuse time-current curves, fuse peak let-through current graphs, circuit breaker time-current curves, and circuit breaker peak current trip settings are needed to conduct these evaluations. The first three are generally available from the device manufacturers. The last, circuit breaker peak current trip settings, can be calculated.

The methods described in this paper are intended to assist system designers in achieving the best overall system design, a design that minimizes downtime without sacrificing equipment protection or personnel safety.

“The methods described in this paper are intended to assist system designers in achieving the best overall system design...”

Appendix C – Recommended Fuses and Their Ratings

A4BQ - Class L
Current-Limiting Fuses
 Voltage Rating:
 600VAC / 500VDC
 Current Rating:
 100A up to 6000A



AJT - Class J
Current-Limiting Fuses
 Voltage Rating:
 600VAC / 500VDC
 Current Rating:
 1A up to 600A



ATDR - Class CC
Current-Limiting Fuses
 Voltage Rating:
 600VAC / 300VDC
 Current Rating:
 0.25A up to 30A



A2D-R / A6D-R - Class RK1
Current-Limiting Fuses
 Voltage Rating:
 600VAC / 600VDC
 Current Rating:
 0.1A up to 600A



TR-R / TRS-R - Class RK5
Current-Limiting Fuses
 Voltage Rating:
 600VAC / 600VDC
 Current Rating:
 0.1A up to 600A



Need more Info? Download our comprehensive white paper on *Selectivity Analysis in Low Voltage Power Distribution Systems with Fuses & Circuit Breakers* at <http://us.ferrazshawmut.com/resources/media/articles/IEEE-Selectivity-Analysis-White-Paper.pdf>

For more information, visit our website at us.ferrazshawmut.com

374 Merrimac Street
 Newburyport, MA 01950
 T: 978-462-6662
 F: 978-462-0181

TF-SC1-001 / Q2500 / 7.09 / WEB

Appendix A – Definition of Terms

Available (Prospective) Fault Current – The current that would flow if each pole of the breaking device under consideration were replaced by a link of negligible impedance without any change of the circuit or the supply [4]

Available (Prospective) Short-Circuit Current – The maximum current that the power system can deliver through a given circuit point to any negligible impedance short-circuit applied at the given point, or at any other point that will cause the highest current to flow through the given point [4]

Current-Limiting Fuse – A fuse that will interrupt all available currents above its threshold current and below its maximum interrupting rating, limit the total clearing time at rated voltage to an interval equal to or less than a the first major or symmetrical loop duration, and limit peak let-through current to a value less than the peak current that would be possible with the fuse replaced by a solid conductor of the same impedance [4]

Instantaneous Trip – A qualifying term indicating that no delay is purposely introduced in the tripping action of the circuit breaker [4]

Minimum Melting Time-current Curve – A graphical representation displaying the minimum melting time, in seconds, for any specified fuse, for a range of overcurrent conditions

Peak Current – The instantaneous value of current at the time of its maximum value [4]

Peak Let-Through Current – The maximum instantaneous current passed by a current-limiting fuse when clearing a fault current of specified magnitude

Selective Coordination – Localization of an overcurrent condition to restrict outages to the circuit or equipment affected, accomplished by the choice of overcurrent protective devices and their ratings or settings [5]

Time versus Current Curve (Time-current Curve) – A graphical representation displaying the average melting time, in seconds, for any specified fuse, for a range of overcurrent conditions

Threshold Current – The magnitude of current at which a fuse becomes current-limiting, specifically the symmetrical root-mean-square (RMS) available current at the threshold of the current-limiting range, where the fuse total clearing time is less than half-cycle at rated voltage and rated frequency, for symmetrical closing, and a power factor of less than 20% [4]

Total Clearing Time-current Curve – A graphical representation displaying the total clearing time (melting and arcing), in seconds, for any specified fuse, for a range of overcurrent conditions

Appendix B – References

- [1] Underwriters Laboratories, UL 248-1 Low Voltage Fuses – Part 1: General Requirements. August 11, 2005. UL Copyrighted Material.
- [2] Marcelo Valdes, Cindy Cline, Steve Hansen, and Tom Papallo, “Selectivity Analysis in Low Voltage Power Distribution Systems with Fuses and Circuit Breakers”, IEEE Industrial and Commercial Power Systems Conference Record May 2009
- [3] Marcelo Valdes, Andrew Crabtree, and Tom Papallo, “Method For Determining Selective Capability of Current-Limiting Overcurrent Devices Using Peak Let-Through Current”, IEEE Industrial and Commercial Power Systems Conference Record May 2009
- [4] Institute of Electrical and Electronics Engineers. The New IEEE Standard Dictionary of Electrical and Electronics Terms. Fifth Edition. New York: IEEE, 1993.
- [5] NFPA, National Fire Protection Association, NEC 2008, National Electric Code® International Electric Code® Series. 2008 Edition. Copyright 2007. Quincy, Massachusetts.