

# APPLICATION INFORMATION

## INDEX TO APPLICATION INFORMATION

Definitions - - - - -	L 2
Fuse Descriptions - - - - -	L 4
Fuse Construction & Operation - - - - -	L 5
How to Read Time vs. Current Curves - - - - -	L 6
Low Voltage Motor Protection - - - - -	L 7
Medium Voltage Motor Protection - - - - -	L 13
Transformer Protection	
General Discussion - - - - -	L 14
Low Voltage Primary - - - - -	L 15
Medium Voltage Primary - - - - -	L 16
Control Transformers - - - - -	L 18
Semiconductor Protection - - - - -	L 19
DC Circuit Protection & Fuse DC Ratings - - - - -	L 19
Let-Thru Current & $I^2t$ - - - - -	L 21
Fuse Let-Thru Tables - - - - -	L 22
Bus Duct Protection - - - - -	L 27
Capacitor Protection - - - - -	L 28
Cable Protection - - - - -	L 29
Welder Protection - - - - -	L 30
Selectivity Between Fuses - - - - -	L 31
Short Circuit Calculations - - - - -	L 37
Properties of Materials - - - - -	L 42
Stranded Copper and Aluminum Cable Data - - - - -	L 43
Recommended Tightening Torque for Bolt-on and Stud Mounted Fuses - - - - -	L 43
Small Ampere Rating Equivalents - - - - -	L 43
Rules for Equipment Short Circuit Rating - - - - -	L 44
Ferraz Shawmut Instructional Videos - - - - -	L 44
10 Reasons for Using Current Limiting Fuses - - - - -	L 44
Suggested Specifications for Ferraz Shawmut Fuses - - - - -	L 45

## FUSE DEFINITIONS

### Ampacity

The current a conductor can carry continuously without exceeding its temperature rating. Ampacity is a function of cable size, insulation type and the conditions of use.

### Ampere Rating

The continuous current carrying capability of a fuse under defined laboratory conditions. The ampere rating is marked on each fuse. Class L fuses and E rated fuses may be loaded to 100% of their ampere rating. For all other fuses, continuous load current should not exceed 80% of fuse ampere rating.

### Available Fault Current

The maximum short circuit current that can flow in an unprotected circuit.

### Bolt-in Fuse

A fuse which is intended to be bolted directly to bus bars, contact pads or fuse blocks.

### Contacts

The external live parts of the fuse which provide continuity between the fuse and the balance of the circuit. Also referred to as ferrules, blades or terminals.

### Coordination

The use of overcurrent protective devices which will isolate only that portion of an electrical system which has been overloaded or faulted. See Selectivity.

### Current-Limiting Fuse

A fuse which will limit both the magnitude and duration of current flow under short circuit conditions.

# APPLICATION INFORMATION

## FUSE DEFINITIONS (Continued)

### Current-Limiting Range

The available fault currents a fuse will clear in less than  $1/2$  cycle, thus limiting the actual magnitude of current flow.

### Dual Element Fuse

Often confused with time delay, dual element is a term describing fuse element construction. A fuse having two current responsive elements in series.

### Element

A calibrated conductor inside a fuse which melts when subjected to excessive current. The element is enclosed by the fuse body and may be surrounded by an arc-quenching medium such as silica sand. The element is sometimes referred to as a link.

### Fault

An accidental condition in which a current path becomes available which by-passes the connected load.

### Fault Current

The amount of current flowing in a faulted circuit.

### Fuse

An overcurrent protective device containing a calibrated current carrying member which melts and opens a circuit under specified overcurrent conditions.

### $I^2t$ (Ampere Squared Seconds)

A measure of the thermal energy associated with current flow.  $I^2t$  is equal to  $(I_{RMS})^2 \times t$ , where  $t$  is the duration of current flow in seconds.

**Clearing  $I^2t$**  is the total  $I^2t$  passed by a fuse as the fuse clears a fault, with  $t$  being equal to the time elapsed from the initiation of the fault to the instant the fault has been cleared.

**Melting  $I^2t$**  is the minimum  $I^2t$  required to melt the fuse element.

### Interrupting Rating (Abbreviated I.R.)

The maximum current a fuse can safely interrupt. Some special purpose fuses may also have a "Minimum Interrupting Rating". This defines the minimum current that a fuse can safely interrupt.

### Kiloamperes (Abbreviated kA)

1,000 amperes.

### Limiters or Back-up Fuse

A special purpose fuse which is intended to provide short circuit protection only.

### Overcurrent

Any current in excess of conductor ampacity or equipment continuous current rating.

### Overload

The operation of conductors or equipment at a current level that will cause damage if allowed to persist.

### Peak Let-Thru Current ( $I_p$ )

The maximum instantaneous current passed by a current-limiting fuse when clearing a fault current of specified magnitude.

### Rejection Fuse Block

A fuse block which will only accept fuses of a specific UL class. Rejection is a safety feature intended to prevent the insertion of a fuse with an inadequate voltage or interrupting rating.

### Rejection Fuse

A current-limiting fuse with high interrupting rating and with unique dimensions or mounting provisions.

### Renewable Fuse

A fuse which can be restored for service by the replacement of its element.

### Renewable Element or Link

The field-replaceable element of a renewable fuse. Also referred to as a renewal link.

### Selectivity

A main fuse and a branch fuse are said to be selective if the branch fuse will clear all overcurrent conditions before the main fuse opens. Selectivity is desirable because it limits outage to that portion of the circuit which has been overloaded or faulted. Also called selective coordination.

### Semiconductor Fuse

An extremely fast acting fuse intended for the protection of power semiconductors. Sometimes referred to as a rectifier or ultra fast fuse.

### Short Circuit

Excessive current flow caused by insulation breakdown or wiring error.

### Threshold Current

The minimum available fault current at which a fuse is current limiting.

### Time Delay Fuse

A fuse which will carry an overcurrent of a specified magnitude for a minimum specified time without opening. The specified current and time requirements are defined in the UL/CSA/NOM 248 fuse standards.

### Voltage Rating

The maximum voltage at which a fuse is designed to operate. Voltage ratings are assumed to be for AC unless specifically labeled as DC.



# APPLICATION INFORMATION

## FUSE DESCRIPTIONS

### High voltage (over 34,500V)

Expulsion-Type power fuses are available for nominal voltages of 46, 69, 115, 138 and 161KV in current ratings up to 400 amperes. ANSI (American National Standards Institute) Standards are followed.

### Medium Voltage (601-34,500V)

➤ **Current-Limiting or Expulsion-Type power fuses** are available for nominal voltages of 2.4, 2.75, 4.16, 5.5, 7.2, 8.25, 14.4, 15.5, 23 and 34.5 KV in current ratings up to 720 amperes. ANSI and UL Standards are followed.

➤ **Current-limiting motor starter fuses** are available for nominal voltages of 2.4, 4.8 and 7.2KV in current ratings up to 36R (650A). These are special purpose R rated fuses for motor short circuit protection only and are not full-range power fuses. ANSI and UL Standards are followed.

➤ **PT Fuses** - Potential transformers require current limiting fuses or equivalent on the primary connection side. Standard PT primary voltages range from 2.4kV to 36kV. Since the power requirement is low (for relays, metering, etc.) fuses of the proper voltage are applied in the 1/2 to 5 ampere range. Several voltage ratings are available, physical sizes vary among manufacturers.

### Low Voltages (600V or less)

Many types of low voltage fuses are classified and identified for use in 125, 250, 300, 480, or 600V circuits. UL/CSA/NOM standards are followed. Common types are briefly summarized below:

### Summary of Low Voltage Fuses

VOLTAGE	FUSE TYPE	AMPERE RATING	INTERRUPTING RATING-KA	NOTES
<b>UL CLASSIFICATIONS</b>				
125	Plug	0-30	10	
250	Class H Class K Class RK1 Class RK5 Midget	0-600 0-600 0-600 0-600 0-30	10 50,100 or 200 200 200 10	Includes renewables Interchangeable with Class H One-end rejection One-end rejection 13/32" x 1- 1/2"
300	Class T	0-1200	200	Very small dimensions
600, 480	Class G	0-60	100	13/32" diameter
600	Class H Class J Class K Class RK1 Class RK5 Class T Class CC Midget Class L	0-600 0-600 0-600 0-600 0-600 0-1200 0-30 0-30 601-6000	10 200 50, 100 or 200 200 200 200 200 10, 50 or 100 200	Includes renewables 600V dimensions. only Interchangeable with Class H One-end rejection One-end rejection Very small dimensions. Midget one-end rejection 13/32" x 1- 1/2" Bolt-in
<b>OTHER TYPES</b>				
130-4000	Semiconductor protection	0-2000	200	Many sizes UL component recognized
1000	Glass & Ceramic	0-30	up to 10	Automotive and electronic, 1/4" dia., 5 mm dia. Many sizes UL Listed & CSA certified
600	Cable protector	4/0-750 kcmil Cu or Al cables	200	Crimp type, bolt type or solid stud
600-4300	Capacitor	25-225	200	Variety of mountings
250, 600	Welder	70-600	200	Class H, J, or L dimensions

# APPLICATION INFORMATION

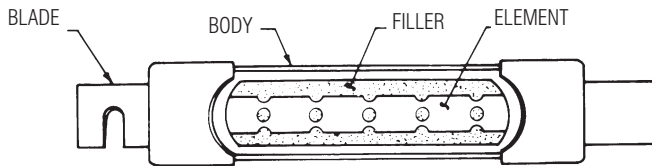

## FUSE CONSTRUCTION AND OPERATION

The typical fuse consists of an element which is surrounded by a filler and enclosed by the fuse body. The element is welded or soldered to the fuse contacts (blades or ferrules).

The element is a calibrated conductor. Its configuration, its mass, and the materials employed are selected to achieve the desired electrical and thermal characteristics. The element provides the current path through the fuse. It generates heat at a rate that is dependent upon its resistance and the load current.

The heat generated by the element is absorbed by the filler and passed through the fuse body to the surrounding air. A filler such as quartz sand provides effective heat transfer and allows for the small element cross-section typical in modern fuses. The effective heat transfer allows the fuse to carry harmless overloads. The small element cross section melts quickly under short circuit conditions. The filler also aids fuse performance by absorbing arc energy when the fuse clears an overload or short circuit.

When a sustained overload occurs, the element will generate heat at a faster rate than the heat can be passed to the filler. If the overload persists, the element will reach its melting point and open. Increasing the applied current will heat the element faster and cause the fuse to open sooner. Thus fuses have an inverse time current characteristic, i.e. the greater the overcurrent the less time required for the fuse to open the circuit.

This characteristic is desirable because it parallels the characteristics of conductors, motors, transformers and other electrical apparatus. These components can carry low level overloads for relatively long times without damage. However, under high current conditions damage can occur quickly. Because of its inverse time current characteristic, a properly applied fuse can provide effective protection over a broad current range, from low level overloads to high level short circuits.



# APPLICATION INFORMATION

## HOW TO READ A TIME-CURRENT CURVE

A time-current characteristic curve for a specific fuse is shown as a continuous line and represents the opening time in seconds for that fuse for a range of overcurrents. The opening time is considered nominal unless noted otherwise. Several curves are traditionally shown on one sheet to represent a family of fuses. The family shown here is the Time Delay Class J AJT Amp-trap 2000 fuse.

Information can be accessed from these curves in several ways:

- If a fuse has been selected, the designer can use the curve for that fuse to check its opening time versus a given overcurrent. Example: Using the 30 ampere fuse curve, what is the fuse opening time in seconds at a current of 160 amperes? At the bottom of the sheet (Current in Amperes) find 160 amperes (Pt. A) and follow that line straight up to the point where it intersects the 30A curve (Pt. B). Then follow that line to the left edge (Time in Seconds) and read 10 seconds. (pt. C). This tells us that the AJT30 will open in 10 seconds on a current of 160 amperes.
- Likewise, for the same fuse we might want to know what current will open the fuse in .1 second. At the side of the sheet (Time in Seconds) find .1 second (Pt. D) and follow that line to the right until it intersects the 30A curve (Pt. E). Then follow that line straight down to the bottom line (Current in Amperes) and read 320 amperes (Pt. F). This shows that the AJT30 requires an overcurrent of 320 amperes to open in .1 second.
- The curves can be used in other ways by the designer. For example, if a family has been chosen (i.e. Time Delay Class J AJT) and an opening time of approximately 1 second is required at 3000 amperes, what fuse in the family best meets this need? Find the 3000 ampere line at the bottom of the sheet (Pt. G) and follow it up to the 1 second line (Pt. H). The nearest curve to the right is the AJT400. If the point is not near a curve shown, other intermediate curves are available from the factory.

Sometimes the fuse family or type has not been chosen, so a design requirement can be presented to several family characteristic curves. One fuse type will emerge as a good choice. Voltage rating, interrupting rating, physical size, time delay, etc. are all considerations in the final choice.

## AJT TIME DELAY / CLASS J

**Melting Time -Current Data  
1-600 Amperes, 600 Volts AC**

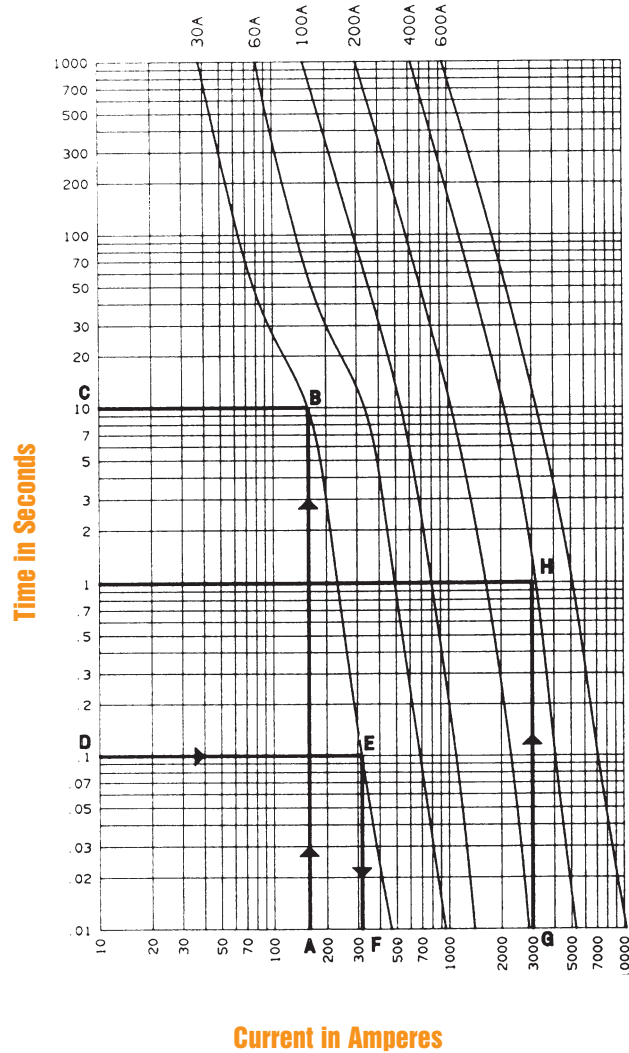

# APPLICATION INFORMATION

## LOW VOLTAGE FUSES FOR MOTOR PROTECTION

### Code Requirements

The NEC or CEC requires that motor branch circuits be protected against overloads and short circuits. Overload protection may be provided by fuses, overload relays or motor thermal protectors. Short circuit protection may be provided by fuses or circuit breakers.

### Overload Protection

The NEC or CEC allows fuses to be used as the sole means of overload protection for motor branch circuits. This approach is often practical with small single phase motors. If the fuse is the sole means of protection, the fuse ampere rating must not exceed the values shown in Table 1.

Most integral horsepower 3 phase motors are controlled by a motor starter which includes an overload relay. Since the overload relay provides overload protection for the motor branch circuit, the fuses may be sized for short circuit protection.

### Short Circuit Protection

The motor branch circuit fuses may be sized as large as shown in Table 2 when an overload relay or motor thermal protector is included in the branch circuit. Time delay fuse ratings may be increased to 225% and non-time delay fuse ratings to 400% (300% if over 600 amperes) if the ratings shown in Table 2 will not carry motor starting current.

Some manufacturers' motor starters may not be adequately protected by the maximum fuse sizing shown in Table 2. If this is the case, the starter manufacturer is required by UL 508 to label the starter with a maximum permissible fuse size. If so labeled, this maximum value is not to be exceeded.

Where the percentages shown in Table 2 do not correspond to standard fuse ratings the next larger fuse rating may be used.

Standard fuse ratings in amperes:

15	20	25	30	35	40	45	50
60	70	80	90	100	110	125	150
175	200	225	250	300	350	400	450
500	600	700	800	1000	1200	1600	2000
2500	3000	4000	5000	6000			

### Fuse Selection Guidelines

What fuse type and ampere rating is best for a given application? The answer depends upon the application and objective to be met. Here are some suggestions.

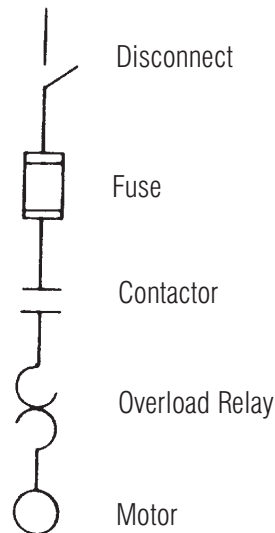

### Motor Branch Circuit

**Table 1- Maximum Fuse Rating for Overload Protection**

MOTOR SERVICE FACTOR or MARKED TEMPERATURE RISE	FUSE RATING AS %* MOTOR FULL LOAD
Service factor of 1.15 or greater	125
Marked temperature rise not exceeding 40°C	125
All others	115

\* These percentages are not to be exceeded.

**Table 2- Maximum Fuse Rating For Short Circuit Protection**

TYPE OF MOTOR	FUSE RATING AS % MOTOR FULL LOAD*	
	FUSE TYPE	
	NON-TIME DELAY	TIME DELAY
All Single-phase AC motors	300	175
AC polyphase motors other than wound-rotor:		
Squirrel Cage		
Other than Design E	300	175
Design E	300	175
Synchronous	300	175
Wound rotor	150	150
Direct-current (constant voltage)	150	150

\* The non-time delay ratings apply to all class CC fuses.



# APPLICATION INFORMATION

## LOW VOLTAGE FUSES FOR MOTOR PROTECTION (Continued)

### Time Delay vs. Non-Time Delay

Time delay fuses are the most useful fuses for motor branch circuit application. A time delay fuse can be sized closer to motor full load current, providing a degree of overload protection, better short circuit protection, and possible use of a smaller disconnect switch.

### Which Fuse Class?

UL Classes RK5, RK1, and J are the most popular. The Class RK5 (Tri-onic®) is the least expensive. The Class RK1 (Amp-trap®) is used where a higher degree of current limitation is required for improved component protection or system coordination. The RK5 and RK1 are dimensionally interchangeable.

Since its 1983 introduction, the Class J time delay fuse (Shawmut AJT) has become an increasingly popular choice. The AJT provides a higher degree of current limitation than the RK1. More important, the AJT is approximately half the physical size of the Class RK5 and RK1 fuses.

### What Ampere Rating?

The selection of fuse ampere rating is a matter of experience and personal preference. Some prefer to size time delay fuses at 125% of motor full load amperes. This sizing will provide a degree of overload protection for motors with a service factor of 1.15. Sizing fuses at 125% of motor nameplate amperes in some applications may result in nuisance fuse openings. Time delay fuses sized at 125% may open at motor locked rotor current before some NEMA Class 20 overload relays operate. Nuisance fuse openings may result if Class RK1 or Class J fuses are sized at 125% of motor full load current. These fuses are more current limiting than the RK5 and have less short time current carrying capability.

Sizing time delay fuses between 125% and 150% of motor full load current provides advantages. The fuse will coordinate with NEMA Class 20 overload relays. Nuisance fuse opening will virtually be eliminated and effective short circuit protection will be maintained.

### Protecting IEC Style Motor Starters

The new IEC European style motor starters and contactors are becoming increasingly popular but they present different problems in protection. These devices represent substantial savings in space and cost but they have a lower withstand capability than their NEMA counterparts.

In order to achieve the same level of protection for IEC style devices that we expect for NEMA devices, the AJT Class J Time Delay fuse is the best choice, sized at 1.25 to 1.50 times motor full load amperes. Also, the AJT has the advantage of being half the size of RK5 and RK1 fuses and thereby fits the trim IEC package.

## Single Phase Motor Fuse Selection UL Class RK5 - Tri-onic® (TR)

MOTOR HP	FULL LOAD AMPERES	RECOMMENDED FUSE AMPERE RATING			
		MINIMUM		TYPICAL	HEAVY LOAD
		1.0 SF	1.15 SF		
<b>115V-RK5-TR (Tri-onic)</b>					
1/6	4.4	5-6/10	5-6/10	6-1/4	8
1/4	5.8	7	8	9	12
1/3	7.2	9	10	12	15
1/2	9.8	12	12	15	17.5
3/4	13.8	15	17-1/2	20	25
1	16	17-1/2	20	25	30
1-1/2	20	20	25	30	35
2	24	25	30	35	40
3	34	35	40	50	60
5	56	60	70	80	100
7-1/2	80	90	100	125	150
10	100	110	125	150	175
<b>115V-CC-ATDR</b>					
1/8	4.4	8	-	15	17-1/2
1/4	5.8	12	-	20	20
1/3	7.2	15	-	25	25
1/2	9.8	20	-	30	-
3/4	13.8	30	-	-	-
<b>230V-RK5-TR (Tri-onic)</b>					
1/6	2.2	2-1/2	2-8/10	3-1/2	4
1/4	2.9	3-2/10	3-1/2	4-1/2	5.6
1/3	3.6	4	4-1/2	5-6/10	7
1/2	4.9	5-6/10	6-1/4	7	9
3/4	6.9	8	9	10	15
1	8	9	10	12	15
1-1/2	10	10	12	15	17-1/2
2	12	12	15	17-1/2	25
3	17	17-1/2	20	25	30
5	28	30	35	40	50
7-1/2	40	45	50	60	70
10	50	60	60	75	90
<b>230V-CC-ATDR</b>					
1/8	2.2	4	-	7	8
1/4	2.9	6	-	9	10
1/3	3.6	7	-	12	15
1/2	4.9	10	-	15	17-1/2
3/4	6.9	15	-	20	25
1	8	17-1/2	-	25	30
1-1/2	10	20	-	30	-
2	12	25	-	-	-

**Minimum** - Largest fuse rating which will provide both overload and short circuit protection per the code. Choosing this fuse rating eliminates the need for an overload relay. Nuisance fuse opening may occur if motor is used with repetitive cycle loads.

**Typical** - Suggested rating when fuse is used in conjunction with an overload relay. Fuse sized near 150% of motor full load current.

**Heavy Load** - In accordance with Table 2. If this fuse is not sufficient to start the load, it may be increased to a maximum of 225% of full-load amperes. This column should be used for Design E and high efficiency Design B motor fuse sizing.

# APPLICATION INFORMATION

## LOW VOLTAGE FUSES FOR MOTOR PROTECTION (Continued)

### Three Phase Motor Fuse Selection UL Classes RK5, RK1 and J

MOTOR HP	FULL LOAD AMPERES	RECOMMENDED FUSE AMPERE RATING								
		MOTOR ACCELERATION TIMES								
		MINIMUM 2 SECS.	TYPICAL 5 SECS.	HEAVY LOAD OVER 5 SECS.	MINIMUM 2 SECS.	TYPICAL 5 SECS.	HEAVY LOAD OVER 5 SECS.	MINIMUM 2 SECS.	TYPICAL 5 SECS.	HEAVY LOAD OVER 5 SECS.
<b>208V</b>		<b>RK5-TR (Tri-onic®)/RK1-A2D</b>			<b>J-AJT</b>			<b>UL CLASS CC ATDR</b>		
1/2	2.4	3	3-1/2	4-1/2	3	3-1/2	4-1/2	5	8	10
3/4	3.5	4-1/2	5	6-1/4	4-1/2	5	6-1/4	7	10	15
1	4.6	6	7	9	6	7	9	10	15	17-1/2
1-1/2	6.6	8	10	12	8	10	12	15	20	25
2	7.5	9	10	15	9	10	15	17-1/2	20	30
3	10.6	15	15	20	15	15	20	25	30	-
5	16.8	20	25	30	20	25	30	-	-	-
7-1/2	24.2	30	35	45	30	35	45	-	-	-
10	30.8	40	45	60	40	45	60	-	-	-
15	46.2	60	70	90	60	70	90	-	-	-
20	60	75	90	110	75	90	110	-	-	-
25	75	90	110	150	90	110	150	-	-	-
30	88	110	150	175	110	150	175	-	-	-
40	114	150	175	200	150	175	200	-	-	-
50	143	175	225	300	175	225	300	-	-	-
60	169	200	250	300	200	250	300	-	-	-
75	211	250	350	400	250	350	400	-	-	-
100	273	350	400	500	350	400	500	-	-	-
125	343	450	500	600	450	500	600	-	-	-
150	396	500	600	-	500	600	-	-	-	-
<b>230V</b>		<b>RK5-TR (Tri-onic® )/RK1-A2D</b>			<b>J-AJT</b>			<b>UL CLASS CC ATDR</b>		
1/2	2.2	2-8/10	3-1/2	4	3	3-1/2	4	5	7	9
3/4	3.2	4	5	6	4	5	6	8	10	12
1	4.2	5	6-1/4	8	5	6-1/4	8	10	12	15
1-1/2	6	8	9	12	8	9	12	15	17-1/2	25
2	6.8	8	10	12	8	10	12	17-1/2	20	25
3	9.6	12	15	17-1/2	12	15	17-1/2	20	30	-
5	15.2	20	25	30	20	25	30	-	-	-
7-1/2	22	30	35	40	30	35	40	-	-	-
10	28	35	40	50	35	40	50	-	-	-
15	42	50	60	80	50	60	80	-	-	-
20	54	70	80	100	70	80	100	-	-	-
25	68	80	100	125	80	100	125	-	-	-
30	80	100	125	150	100	125	150	-	-	-
40	104	125	150	200	125	150	200	-	-	-
50	130	175	200	250	175	200	250	-	-	-
60	154	200	225	300	200	225	300	-	-	-
75	192	250	300	350	250	300	350	-	-	-
100	248	300	350	450	300	350	450	-	-	-
125	312	400	450	600	400	450	600	-	-	-
150	360	450	500	600	450	500	600	-	-	-
200	480	600	-	-	600	-	-	-	-	-

**Minimum** - Fuses are sized near 125% of motor load current. This sizing is not recommended if motor acceleration time exceeds 2 seconds. Minimum sizing will provide close overload relay back-up protection but may not coordinate with some NEMA Class 20 overload relays. Also, for RK1 and J fuses, minimum sizing may not be heavy enough for motors with code letter G or higher.

**Typical** - Suggested for most applications. Will coordinate with NEMA Class 20 overload relays. Suitable for motor acceleration times up to 5 seconds.

**Heavy Load** - In accordance with Table 2. If this fuse is not sufficient to start the load, it may be increased to a maximum of 225% of full-load amperes. This column should be used for Design E and high efficiency Design B motor fuse sizing.



# APPLICATION INFORMATION

## LOW VOLTAGE FUSES FOR MOTOR PROTECTION (Continued)

### Three Phase Motor Fuse Selection UL Classes RK5, RK1 and J

MOTOR HP	FULL LOAD AMPERES	RECOMMENDED FUSE AMPERE RATING								
		MOTOR ACCELERATION TIMES								
		MINIMUM 2 SECS.	TYPICAL 5 SECS.	HEAVY LOAD OVER 5 SECS.	MINIMUM 2 SECS.	TYPICAL 5 SECS.	HEAVY LOAD OVER 5 SECS.	MINIMUM 2 SECS.	TYPICAL 5 SECS.	HEAVY LOAD OVER 5 SECS.
<b>380V</b>		<b>RK5-TRS (Tri-onic®)/RK1-A6D</b>			<b>J-AJT</b>			<b>UL Class CC ATDR</b>		
1/2	1.3	1-6/10	2	2-8/10	1-6/10	2	2-8/10	3	4	5-6/10
3/4	1.7	2-1/2	2-8/10	3-1/2	2-1/2	2-8/10	3-1/2	4	6	8
1	2.2	3-2/10	4	4-1/2	3-2/10	4	4-1/2	5	8	10
1-1/2	3.6	4-1/2	5-6/10	7	4-1/2	5-6/10	7	8	12	15
2	4.1	5	6	8	5	6	8	9	15	17-1/2
3	5.8	7	8	12	8	8	12	12	17-1/2	25
5	9.2	12	15	17-1/2	12	15	17-1/2	20	30	-
7-1/2	13.3	15	20	25	17-1/2	20	25	30	-	-
10	17	20	25	30	20	25	30	-	-	-
15	25	30	35	45	30	35	45	-	-	-
20	33	40	45	60	40	50	60	-	-	-
25	41	50	60	75	50	60	75	-	-	-
30	48	60	70	90	60	80	90	-	-	-
40	68	75	90	125	80	100	125	-	-	-
50	79	90	110	150	90	125	150	-	-	-
60	93	110	125	175	110	150	175	-	-	-
75	116	150	175	225	150	175	225	-	-	-
100	150	175	225	300	175	225	300	-	-	-
125	189	250	300	350	250	300	350	-	-	-
150	218	300	350	400	300	350	400	-	-	-
200	291	350	450	600	350	450	600	-	-	-

**Minimum** - Fuses are sized near 125% of motor load current. This sizing is not recommended if motor acceleration time exceeds 2 seconds. Minimum sizing will provide close overload relay back-up protection but may not coordinate with some NEMA Class 20 overload relays. Also, for RK1 and J fuses, minimum sizing may not be heavy enough for motors with code letter G or higher.

**Typical** - Suggested for most applications. Will coordinate with NEMA Class 20 overload relays. Suitable for motor acceleration times up to 5 seconds.

**Heavy Load** - In accordance with Table 2. If this fuse is not sufficient to start the load, it may be increased to a maximum of 225% of full-load amperes. This column should be used for Design E and high efficiency Design B motor fuse sizing.

# APPLICATION INFORMATION

## LOW VOLTAGE FUSES FOR MOTOR PROTECTION (Continued)

### Three Phase Motor Fuse Selection UL Classes RK5, RK1 and J

MOTOR HP	FULL LOAD AMPERES	RECOMMENDED FUSE AMPERE RATING								
		MOTOR ACCELERATION TIMES								
		MINIMUM 2 SECS.	TYPICAL 5 SECS.	HEAVY LOAD OVER 5 SECS.	MINIMUM 2 SECS.	TYPICAL 5 SECS.	HEAVY LOAD OVER 5 SECS.	MINIMUM 2 SECS.	TYPICAL 5 SECS.	HEAVY LOAD OVER 5 SECS.
<b>460V</b>		<b>RK5-TRS (Tri-onic®)/RK1-A6D</b>			<b>J-AJT</b>			<b>UL CLASS CC ATDR</b>		
1/2	1.1	1-4/10	1-6/10	2	1-1/2	1-6/10	2	3	3-1/2	4-1/2
3/4	1.6	2	2-1/4	2-8/10	2	2-1/4	2-8/10	3-1/2	5	6-1/4
1	2.1	2-1/2	3-2/10	4	2-1/2	3-2/10	4	5	6-1/4	9
1-1/2	3	3-1/2	4-1/2	5-6/10	3-1/2	4-1/2	5-6/10	6	9	12
2	3.4	4	5	6	4	5	6	8	10	15
3	4.8	5-6/10	7	9	6	8	9	12	15	17-1/2
5	7.6	10	12	15	10	12	15	15	25	30
7-1/2	11	15	17-1/2	20	15	17-1/2	20	25	30	-
10	14	17-1/2	20	25	17-1/2	20	25	30	-	-
15	21	25	30	40	25	30	40	-	-	-
20	27	35	40	50	35	40	50	-	-	-
25	34	40	50	60	40	50	60	-	-	-
30	40	50	60	70	50	60	70	-	-	-
40	52	70	80	100	70	80	100	-	-	-
50	65	80	100	125	80	100	125	-	-	-
60	77	100	125	150	100	125	150	-	-	-
75	96	125	150	175	125	150	175	-	-	-
100	124	175	200	225	175	200	225	-	-	-
125	156	200	225	300	200	225	300	-	-	-
150	180	225	250	350	225	250	350	-	-	-
200	240	300	350	450	300	350	450	-	-	-
250	302	400	450	600	400	450	600	-	-	-
300	361	450	600	-	450	600	-	-	-	-
		<b>CLASS L-A4BT</b>								
300	360	--	601	650						
400	477	--	800	900						
500	590	--	1000	1100						

**Minimum** - Fuses are sized near 125% of motor load current. This sizing is not recommended if motor acceleration time exceeds 2 seconds. Minimum sizing will provide close overload relay back-up protection but may not coordinate with some NEMA Class 20 overload relays. Also, for RK1 and J fuses, minimum sizing may not be heavy enough for motors with code letter G or higher.

**Typical** - Suggested for most applications. Will coordinate with NEMA Class 20 overload relays. Suitable for motor acceleration times up to 5 seconds.

**Heavy Load** - In accordance with Table 2. If this fuse is not sufficient to start the load, it may be increased to a maximum of 225% of full-load amperes. This column should be used for Design E and high efficiency Design B motor fuse sizing.



# APPLICATION INFORMATION

## LOW VOLTAGE FUSES FOR MOTOR PROTECTION (Continued)

### Three Phase Motor Fuse Selection UL Classes RK5, RK1 and J

MOTOR HP	FULL LOAD AMPERES	RECOMMENDED FUSE AMPERE RATING								
		MOTOR ACCELERATION TIMES								
		MINIMUM 2 SECS.	TYPICAL 5 SECS.	HEAVY LOAD OVER 5 SECS.	MINIMUM 2 SECS.	TYPICAL 5 SECS.	HEAVY LOAD OVER 5 SECS.	MINIMUM 2 SECS.	TYPICAL 5 SECS.	HEAVY LOAD OVER 5 SECS.
<b>575V</b>		<b>RK5-TRS (Tri-onic®)/RK1-A6D</b>			<b>J-AJT</b>			<b>UL CLASS CC ATDR</b>		
1/2	.9	1-1/8	1-4/10	1-6/10	1-1/4	1-1/2	1-6/10	2-1/2	2-8/10	3-1/2
3/4	1.3	1-6/10	2	2-1/2	1-6/10	2	2-1/2	3	4	5-6/10
1	1.7	2-1/4	2-1/2	3	2-1/4	2-1/2	3	4	5-6/10	6-1/4
1-1/2	2.4	3	3-1/2	4-1/2	3	3-1/2	4-1/2	5	8	10
2	2.7	3-2/10	4	5	3-2/10	4	5	6	8	10
3	3.9	5	6	7	5	6	7	9	12	15
5	6.1	8	9	12	8	10	12	15	17-1/2	25
7-1/2	9	12	15	17-1/2	12	15	17-1/2	20	30	-
10	11	15	17-1/2	20	15	17-1/2	20	25	30	-
15	17	20	25	30	20	25	30	-	-	-
20	22	30	35	40	30	35	40	-	-	-
25	27	35	40	50	35	40	50	-	-	-
30	32	40	50	60	40	50	60	-	-	-
40	41	50	60	75	50	60	75	-	-	-
50	52	70	80	100	70	80	100	-	-	-
60	62	75	90	110	80	90	110	-	-	-
75	77	100	125	150	100	125	150	-	-	-
100	99	125	150	175	125	150	175	-	-	-
125	125	150	175	225	150	200	225	-	-	-
150	144	175	225	300	175	225	300	-	-	-
200	192	250	300	350	250	300	350	-	-	-
250	240	300	350	500	300	350	500	-	-	-
300	289	350	450	600	350	450	600	-	-	-
		<b>CLASS L-A4BT</b>								
400	382	--	601	700						
500	472	--	700	1000						

**Minimum** - Fuses are sized near 125% of motor load current. This sizing is not recommended if motor acceleration time exceeds 2 seconds. Minimum sizing will provide close overload relay back-up protection but may not coordinate with some NEMA Class 20 overload relays. Also, for RK1 and J fuses, minimum sizing may not be heavy enough for motors with code letter G or higher.

**Typical** - Suggested for most applications. Will coordinate with NEMA Class 20 overload relays. Suitable for motor acceleration times up to 5 seconds.

**Heavy Load** - In accordance with Table 2. If this fuse is not sufficient to start the load, it may be increased to a maximum of 225% of full-load amperes. This column should be used for Design E and high efficiency Design B motor fuse sizing.

# APPLICATION INFORMATION

## MEDIUM VOLTAGE MOTOR PROTECTION

### Fuse Application Guidelines

The guidelines for applying R-rated fuses are significantly different from those applying to low voltage motor fuses. This is because R-rated fuses are special purpose devices which are intended to provide short circuit protection only for medium voltage starters and motors.

An R-rated fuse is not designed to protect itself or other circuit components during long term overloads. This is why these fuses are given an R rating, and not an ampere rating. An R-rated fuse will safely interrupt any current between its minimum interrupting rating and its maximum interrupting rating. The minimum interrupting rating is verified during UL tests for UL component recognition.

R-rated fuses must be applied in combination with an overload relay and a contactor. The time current characteristics of the fuse and overload relay should be matched so that the contactor interrupts currents below the fuse's minimum interrupting rating while the fuse interrupts fault currents, thus easing duty on the contactor and extending the interrupting ability of the controller.

A medium voltage starter is usually engineered for a specific motor and application. For this reason the starter manufacturer generally selects the proper fuse R rating and provides the fuses as part of the starter package. Unless the user has good reason, no deviation should be made from the R rating recommended by the starter manufacturer. If the user has an existing starter which is to be applied to a new or different motor, the application should be reviewed with the starter manufacturer. Recalibration of the overload relay(s) or fuses of a different R rating may be required.

Properly sized R-rated fuses should provide a service life approaching that of the contactor. If fuse openings are experienced with no faults present, the fuses, overload relay or both may be improperly sized. The table in this section is offered as a guideline and shows the maximum motor full load current appropriate for a given R rating. In addition to this table it is advisable to compare the fuse minimum melt time-current curve and the nominal time-current characteristic curve for the overload relay. These curves should intersect at (B) no less than 120% of motor locked rotor current (see figure). This will assure that the contactor will open before the fuse during locked rotor conditions.

### The 10 or 3 Second Start

The 10 or 3 Second Start listed in the table is a start during which the motor accelerates from standstill to rated speed in 10 (or 3) seconds or less. For reduced voltage starting, motor starting current should not exceed 75% of the fuse minimum melt current for the required motor acceleration time.

Consult the factory for application assistance for ratings above 36R.

### Fuse/Overload Relay Crossover Point

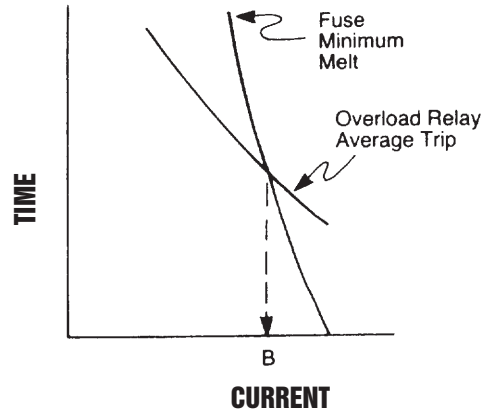

where  $B \geq 1.2 \times$  locked rotor amperes

### Motor Full Load Currents for R-Rated Fuses\*

FUSE R RATING	MAX. MOTOR FULL-LOAD CURRENT FOR FULL VOLTAGE START - AMPERES	
	10 sec. start	3 sec. start
2R	28	32
3R	40	45
4R	55	65
6R	80	95
9R	125	140
12R	165	190
18R	250	280
24R	330	360
36R	500	550

\*Note: Always round up to the next larger R rating.



# APPLICATION INFORMATION

## TRANSFORMER PROTECTION

The National Electrical Code and the Canadian Electrical Code cover overcurrent protection of transformers. Some of the requirements in this article are summarized here.

### Transformers - Primary 600 Volts or Less

If secondary fuse protection is not provided, primary fuses are to be selected according to Table 1. If both primary and secondary fuses are used, they are to be selected according to Table 2.

**Table 1- Primary Fuse Only**

TRANSFORMER PRIMARY AMPERES	MAXIMUM PRIMARY FUSE % RATING
9 or more	125*
2 to less than 9	167
less than 2	300

**Table 2- Primary & Secondary Fuses**

TRANSFORMER SECONDARY AMPERES	MAXIMUM % RATING	
	PRIMARY FUSE	SECONDARY FUSE
9 or more	250	125*
less than 9	250	167

\* If 125% does not correspond to a standard ampere rating, the next higher standard rating shall be permitted.

### Transformer Magnetizing Inrush Currents

When voltage is switched on to energize a transformer, the transformer core normally saturates. This results in a large inrush current which is greatest during the first half cycle (approximately .01 second) and becomes progressively less severe over the next several cycles (approximately .1 second) until the transformer reaches its normal magnetizing current.

To accommodate this inrush current, fuses are often selected which have time-current withstand values of at least 12 times transformer primary rated current for .1 second and 25 times for .01 second. Recommended primary fuses for popular, low-voltage 3-phase transformers are shown on the next page. Some small dry-type transformers may have substantially greater inrush currents. For these applications, the fuse may have to be selected to withstand 45 times transformer primary rated current for .01 second.

## Secondary Fuses

Selecting fuses for the secondary is simple once rated secondary current is known. Fuses are sized at 125% secondary FLA or next higher rating or at maximum 167% of secondary FLA depending on secondary current. The preferred sizing is 125% of rated secondary current (Isec) or next higher fuse rating. To determine Isec, first determine transformer rating (VA or kVA), secondary voltage (Vsec) and use formula's below.

- Single Phase :  $I_{sec} = \frac{\text{Transformer VA}}{V_{sec}}$   
or  $\frac{\text{Transformer kVA} \times 1000}{V_{sec}}$
- Three Phase :  $I_{sec} = \frac{\text{Transformer VA}}{1.73 \times V_{sec}}$   
or  $\frac{\text{Transformer kVA} \times 1000}{1.73 \times V_{sec}}$

When Isec is determined, multiply it by 1.25 and choose that fuse rating or next higher rating. [ Isec x 1.25 = Fuse Rating ]

### Transformers - Primary Over 600 Volts

If in unsupervised locations, fuses are to be selected according to Table 3. Where the required fuse rating does not correspond to a standard ampere rating, the next higher standard rating shall be permitted. In supervised locations, fuses are to be selected according to Table 4.

**Table 3- Unsupervised Locations**

TRANSFORMER RATED % IMPEDANCE	MAXIMUM % RATING		
	PRIMARY FUSE	SECONDARY FUSE	
		OVER 600V	600V or LESS
6 or less	300*	250*	125*
More than 6 & not more than 10	300*	225*	125*

**Table 4- Supervised Locations**

TRANSFORMER RATED % IMPEDANCE	MAXIMUM % RATING		
	PRIMARY FUSE	SECONDARY FUSE	
		OVER 600V	600V or LESS
All	250	-	-
6 or less	300	250	250
More than 6 & not more than 10	300	225	250

\* Where fuse sizes do not correspond to a standard ampere rating, the next higher standard rating shall be permitted.

# APPLICATION INFORMATION

## PRIMARY FUSES FOR THREE PHASE LOW VOLTAGE TRANSFORMERS

### Recommended Primary Fuses for 240 Volt, Three Phase Transformers

TRANSFORMER RATING KVA	240 VOLT PRIMARY					
	PRIMARY FULL LOAD AMPS	PRIMARY FUSE RATING				
		TR-R	AJT* or A2D-R*	A4BT*	A4BY*	A4BQ*
3	7.2	9	15	-	-	-
5	12	15	25	-	-	-
7-1/2	18	25	40	-	-	-
9	22	30	45	-	-	-
15	36	45	60	-	-	-
30	72	90	150	-	-	-
45	108	150	225	-	-	-
75	180	225	400	-	-	-
100	241	300	450	-	-	-
112-1/2	271	350	500	-	-	-
150	361	450	600	-	-	-
225	541	600	-	800	900	1200
300	722	-	-	1200	1200	1600
500	1203	-	-	1800	2000	2500
750	1804	-	-	-	3000	4000
1000	2406	-	-	-	5000	5000
1500	3608	-	-	-	6000	-

### Recommended Primary Fuses for 480 & 600 Volt, Three Phase Transformers

TRANSFORMER RATING KVA	480 VOLT PRIMARY						600 VOLT PRIMARY					
	PRIMARY FULL LOAD AMPS	PRIMARY FUSE RATING					PRIMARY FULL LOAD AMPS	PRIMARY FUSE RATING				
		TRS-R	AJT* or A6D-R*	A4BT*	A4BY*	A4BQ*		TRS-R	AJT* or A6D-R*	A4BT*	A4BY*	A4BQ*
3	3.6	4-1/2	6	-	-	-	2.9	4	5	-	-	-
5	6.0	8	12	-	-	-	4.8	6	10	-	-	-
7-1/2	9.0	12	15	-	-	-	7.2	9	15	-	-	-
9	11	15	25	-	-	-	9.0	12	17-1/2	-	-	-
15	18	25	35	-	-	-	14	20	25	-	-	-
30	36	45	60	-	-	-	29	35	45	-	-	-
45	54	70	100	-	-	-	43	60	80	-	-	-
75	90	125	175	-	-	-	72	90	150	-	-	-
100	120	150	225	-	-	-	96	125	200	-	-	-
112-1/2	135	175	300	-	-	-	108	150	225	-	-	-
150	180	225	400	-	-	-	144	200	300	-	-	-
225	271	350	500	-	-	-	217	300	450	-	-	-
300	361	450	600	-	-	-	289	350	500	-	-	-
500	601	-	-	1000	1000	1200	481	600	-	700	900	1000
750	902	-	-	1400	1600	2000	722	-	-	1200	1400	1600
1000	1203	-	-	1800	2000	2500	962	-	-	1600	1800	2000
1500	1804	-	-	-	3000	4000	1443	-	-	2000	2500	3000
2000	2406	-	-	-	4000	5000	1925	-	-	-	4000	4000
2500	3007	-	-	-	5000	6000	2406	-	-	-	5000	5000

\*When using these fuses, the secondary of the transformer must be fused to comply with the Code.



# APPLICATION INFORMATION

## E-RATED PRIMARY FUSES FOR THREE PHASE POWER TRANSFORMERS

### Primary Fuse Ratings - 2400, 4160, 4800 Volts

TRANSFORMER RATING KVA <sup>2</sup>	PRIMARY FUSE RATING <sup>1</sup>								
	2400V (A055)			4160V (A055)			4800V (A055)		
	FULL LOAD AMPERES	MIN.	133%	FULL LOAD AMPERES	MIN.	133%	FULL LOAD AMPERES	MIN.	133%
112-1/2	27	30E	40E	16	20E	20E	14	20E	20E
150	36	40E	50E	21	25E	30E	18	20E	25E
225	54	65E	80E	31	40E	40E	27	30E	40E
300	72	80E	100E	42	50E	65E	36	40E	50E
500	120	125E	200E	69	80E	100E	60	65E	80E
750	180	200E	250E	104	125E	150E	90	100E	125E
1000	241	250E	400E	139	150E	200E	120	125E	200E
1500	361	400E	500E	208	250E	300E	180	200E	250E
2000	482	600E	-	278	300E	400E	241	250E	400E
2500	602	-	-	348	400E	500E	301	350E	400E
3000	722	-	-	416	450E	600E	361	400E	500E
3750	902	-	-	520	600E	750E	451	500E	600E
5000	1203	-	-	694	750E	-	601	750E	900E

### Primary Fuse Ratings - 6900, 7200, 8320 Volts

TRANSFORMER RATING KVA <sup>2</sup>	PRIMARY FUSE RATING <sup>1</sup>								
	6900V* (A825X)*			7200V* (A825X)*			8320 (A155)		
	FULL LOAD AMPERES	MIN.	133%	FULL LOAD AMPERES	MIN.	133%	FULL LOAD AMPERES	MIN.	133%
112-1/2	9	-	-	9	-	-	7.8	10E	10E
150	12	-	20E	12	-	20E	10.4	15E	15E
225	19	25E	25E	18	20E	25E	15.6	20E	20E
300	25	30E	40E	24	30E	40E	20.8	25E	30E
500	42	50E	65E	40	50E	65E	34.7	40E	50E
750	63	80E	100E	60	65E	80E	52	65E	80E
1000	84	100E	125E	80	100E	125E	69.4	80E	100E
1500	126	150E	200E	120	125E	200E	104	125E	150E
2000	167	200E	-	160	200E	200E	139	150E	200E
2500	209	-	-	201	-	-	173	200E	-
3000	251	-	-	241	-	-	208	-	-

<sup>1</sup> Minimum fuse size shown will carry transformer magnetizing inrush current of 12 times full load amperes for .1 second. 133% fuse size permits continuous operation of transformer at 133% of its self cooled KVA rating.

<sup>2</sup> The self-cooled rating of the transformer. (If a forced-air cooled KVA rating is given, use that rating to size the fuse and be sure the fuse will carry the higher load current.)

### Recommended Fuses

Ferraz Shawmut CS-3: 5KV-A055F, 8KV-A825X\*, 15KV-A155F, CL-14: 5KV-A055C, A055B, 15KV-A155C

\* Consult factory for technical information.

### Examples:

1. A new installation has a 300KVA transformer with 4160V primary. It is not fully loaded. What is minimum size primary fuse recommended?

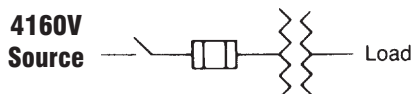

A 50E rating (Ferraz Shawmut A055F1DORO-50E or equivalent) is correct. Lower ratings may open when transformer is energized.

2. What is the normal fuse size recommended for a 1000KVA transformer with 8320V primary?

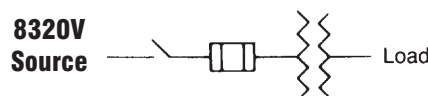

Unless special conditions are noted, the 133% primary fuse rating is correct. For this application use a 100E rating A155F2DORO-100E or equivalent which will allow normal overload operations of transformer up to 133% of rating.

# APPLICATION INFORMATION

## E-RATED PRIMARY FUSES FOR THREE PHASE POWER TRANSFORMERS (Continued)

### Primary Fuse Ratings - 12,000, 12,470, 13,200 Volts

TRANSFORMER RATING KVA <sup>2</sup>	PRIMARY FUSE RATING <sup>1</sup>								
	12,000V (A155)			12,470V (A155)			13,200V (A155)		
	FULL LOAD AMPERES	MIN.	133%	FULL LOAD AMPERES	MIN.	133%	FULL LOAD AMPERES	MIN.	133%
112-1/2	5.4	10E	10E	5.2	10E	10E	4.9	10E	10E
150	7.0	10E	10E	7.0	10E	10E	6.6	10E	10E
225	10.8	15E	15E	10.4	15E	15E	9.8	15E	15E
300	14.4	20E	20E	14	15E	20E	13	15E	20E
500	24	30E	40E	23	25E	30E	22	25E	30E
750	36	40E	50E	35	40E	50E	33	40E	50E
1000	48	65E	65E	46	50E	65E	44	50E	65E
1500	72	80E	100E	70	80E	100E	66	80E	100E
2000	96	125E	150E	92	100E	125E	88	100E	125E
2500	120	125E	200E	116	125E	200E	109	125E	150E
3000	144	150E	200E	139	150E	200E	131	150E	200E

### Primary Fuse Ratings -13,800, 14,400 Volts

TRANSFORMER RATING KVA <sup>2</sup>	PRIMARY FUSE RATING <sup>1</sup>					
	13,800V (A155)			14,400V (A155)		
	FULL LOAD AMPERES	MIN.	133%	FULL LOAD AMPERES	MIN.	133%
112-1/2	4.7	10E	10E	4.5	10E	10E
150	6.2	10E	10E	6.0	10E	10E
225	9.4	15E	15E	9.0	10E	15E
300	12.6	15E	20E	12	15E	20E
500	21	25E	30E	20	25E	30E
750	32	40E	50E	30	40E	40E
1000	42	50E	65E	40	50E	65E
1500	63	80E	100E	60	65E	80E
2000	84	100E	125E	80	100E	125E
2500	105	125E	150E	100	125E	150E
3000	125	150E	200E	120	150E	200E

<sup>1</sup> Minimum fuse size shown will carry transformer magnetizing inrush current of 12 times full load amperes for .1 second.  
133% fuse size permits continuous operation of transformer at 133% of its self cooled KVA rating.

<sup>2</sup> The self-cooled rating of the transformer. (If a forced-air cooled KVA rating is given, use that rating to size the fuse and be sure the fuse will carry the higher load current.)

### Recommended Fuses

Ferraz Shawmut CS-3: 5KV-A055F, 15KV-A155F, CL-14: 5KV-A055C, A055B, 15KV-A155C

### Maximum Fuse Size

The Code allows primary fuses to be sized up to 250% of transformer primary current rating. Sizing this large may not provide adequate protection. Maximum fuse size should be determined by making sure the fuse total clearing curve does not exceed transformer damage curve. The transformer manufacturer should be consulted to determine transformer overload and short circuit withstand capability.



# APPLICATION INFORMATION

## CONTROL CIRCUIT TRANSFORMERS

Control circuit transformers used as part of a motor control circuit are to be protected as outlined in Tables 1 & 2 (p. AP13) with one important exception. Primary fuses may be sized up to 500% of transformer rated primary current if the rated primary current is less than 2 amperes.

When a control circuit transformer is energized, the typical magnetizing inrush will be 25-40 times rated primary full load current (FLA) for the first 1/2 cycle and dissipates to rated current in a few cycles. Fuses must be sized so they do not open during this

inrush. We recommend that fuses be selected to withstand 40 x FLA for .01 sec. and to stay within the NEC guidelines specified above.

For example: 300VA Transformer, 600 V primary.

$$I_{pri} = \frac{\text{Transformer VA}}{\text{Primary V}} = \frac{300}{600} = 1/2A = \text{FLA}$$

The fuse time-current curve must lie to the right to the point 40 x (1/2A) = 20A @ .01 sec.

## Recommended Primary Fuses for Single Phase Control Transformers

TRANS VA	600 VOLT PRIMARY						480 VOLT PRIMARY					
	FLA	ATQR	ATMR	A6D-R+	AJT+	TRS-R	FLA	ATQR	ATMR	A6D-R+	AJT+	TRS-R
25	.042	1/10	2/10	2/10	-	1/10	.052	1/10	1/4	1/4	-	1/10
50	.083	1/4	3/10*	4/10	-	2/10	.104	1/4	1/2*	1/2	-	2/10
75	.125	1/4	1/2*	6/10	-	2/10	.156	3/10	3/4*	6/10	-	2/10
100	.167	3/10	3/4*	8/10	-	3/10	.208	4/10	1	1	1	3/10
130	.22	4/10	1	1-1/4	1-1/4	4/10	.27	1/2	1	1-4/10	1-1/2	4/10
150	.25	1/2	1*	1-1/4	1	4/10	.313	1/2	1-1/2	1-4/10	1-1/2	4/10
200	.33	1/2	1-1/2	1-6/10	1-1/2	6/10	.417	6/10	2	2	2	6/10
250	.42	6/10	2	2	2	6/10	.52	8/10	2	2-1/2	2-1/2	6/10
300	.50	1	2	2-1/2	2	8/10	.62	1-1/2	3	3	3	8/10
350	.583	1-1/4	2	2-8/10	2	1	.73	1-1/2	3-1/2	3-1/2	3-1/2	1
500	.833	1-1/2	4	4	4	1-1/4	1.04	2	5	4	4	1-4/10
750	1.25	2-1/2	6	4	4	1-6/10	1.56	3	7	5	5	2
1000	1.67	3	8	5	5	2-1/4	2.08	4+	-	5	5	3
1500	2.5	5+	-	6	6	4	3.125	7+	-	6-1/4	6-1/4	4
2000	3.33	8+	-	8	8	5	4.17	10+	-	7	7	5
3000	5.00	12+	-	12	12*	8	6.25	15+*	-	15*	15	8
5000	8.33	20+	-	20*	20**	12	10.4	25+**	-	25*	25*	15
7500	12.5	30+	-	30*	30*	17-1/2	15.6	-	-	35**	35**	20
10000	16.7	-	-	40*	40*	25	20.8	-	-	50**	50**	30
TRANS VA	240 VOLT PRIMARY						120 VOLT PRIMARY					
	FLA	ATQR	ATMR	A6D-R+	AJT+	TRS-R	FLA	ATQR	ATMR	A6D-R+	AJT+	TRS-R
25	.104	2/10	1/2	1/2	-	2/10	.21	4/10	1	1	1	3/10
50	.21	4/10	1	1	1	3/10	.42	6/10	2	2	2	6/10
75	.31	1/2	1-1/2	1-4/10	1-1/2	4/10	.6	1	3	3	3	8/10
100	.42	6/10	2	2	2	6/10	.83	1-1/2	4	4	4	1
130	.54	1	2-1/2	2-1/2	2-1/2	8/10	1.08	2-1/2	5	4	4	1-6/10
150	.625	1	3	3	3	8/10	1.25	2-1/2	6	4	4	1-6/10
200	.83	1-1/2	4	3-1/2	3-1/2	1	1.67	3+	8	5	5	2-1/4
250	1.04	2	5	4	4	1-4/10	2.08	4+	-	5	5	2-8/10
300	1.25	2-1/2	6	4	4	1-6/10	2.5	5+	-	6	6	3-2/10
350	1.46	3	7	5	5	2	2.92	7+	-	6	6	4
500	2.08	4+	-	5	5	2-8/10	4.17	10+	-	10	6	5.6
750	3.13	7+	-	6-1/4	6-1/4	4	6.25	15+	-	15**	15	8
1000	4.2	10+	-	7	7	5-6/10	8.33	20+	-	20**	20*	12
1500	6.25	15+	-	15	15	8	12.5	30+	-	30	30	15
2000	8.3	20+	-	20**	20**	12	16.7	-	-	40**	40	25
3000	12.5	30+	-	30**	30**	15	25	-	-	60**	60*	35
5000	20.8	-	-	50**	50*	25	41.7	-	-	100**	100**	60
7500	31.3	-	-	70**	70**	40	62.5	-	-	150**	150**	90
10000	41.7	-	-	100**	100**	60	83.3	-	-	200**	200**	125

The above fuses will withstand 40 x FLA for .01 second except where noted.

+ Secondary fusing required.

\* Fuse will withstand 30 x FLA for .01 second.

\*\* Fuse will withstand 35 x FLA for .01 second.

# APPLICATION INFORMATION

## SEMICONDUCTOR PROTECTION

Solid State devices have progressed through several generations of sophistication since their introduction in the 1940s. Fuse designs have changed to match solid state protection demands.

The protection task looks simple- choose a fuse of correct voltage and ampere rating which will protect a solid state device (diode, silicon-controlled rectifier, triac, etc.) through a wide range of overcurrents, yet carry normal rated loads without deterioration through a long life.

Solid state power devices operate at high current densities. Cooling is a prime consideration. The fuse should be cooled with the solid state device. Cycling conditions must be considered. The ability of solid state devices to switch high currents at high speed subjects fuses to thermal and mechanical stresses. Proper fuse selection is mandatory for long-term reliability.

**For application guidelines, request the Ferraz Shawmut publication titled *Power Semiconductor Fuse Application Guide*, and the software program, *Select a Fuse for Power Electronics*.**

## DC CIRCUIT PROTECTION

AC applications are more common than DC. This is why fuses are generally designed, tested and rated for AC. Fuses rated for AC are also capable to DC circuit interruption. The key question is how much DC voltage interrupting capability does an AC rated fuse have? There is no safe rule of thumb that will convert AC voltage rating to a DC voltage rating. Testing is required to determine the DC voltage rating of a fuse, and Technical Services must be consulted.

## DC Circuit Parameters

The degree of difficulty of interrupting a DC circuit is a function of the voltage, current and circuit time constant. The higher the voltage and time constant, the more difficult the interruption is for the fuse.

Time constant is defined as  $t = L/R$  where:

- t** is time constant in seconds
- L** is inductance in henrys
- R** is resistance in ohms

If rated voltage is applied, 63% of rated current will be reached in one time constant.

## DC Short Circuit

Graph A shows the relationship of current as a function of time during a DC short circuit.

Solid state devices have relatively short thermal time constants. An overcurrent which may not harm an electro-mechanical device can cause catastrophic failure of a solid state device.

Many solid state devices have an overcurrent withstand rating which is termed "I<sup>2</sup>t for fusing". These values are found in most power semiconductor application handbooks.

Fuses intended for solid state device protection are rated in terms of total clearing I<sup>2</sup>t. Fuses and devices are matched so that the total clearing I<sup>2</sup>t of the fuse is less than the withstand I<sup>2</sup>t for the device.

The published fuse total clearing I<sup>2</sup>t values are derived from short-circuit test oscillograms of the fuse under controlled conditions. The end application can vary significantly from the tested conditions. The specifier must take these differences into account since they will affect fuse clearing I<sup>2</sup>t.

**Graph A- Current as a Function of Time During a DC Short Circuit**

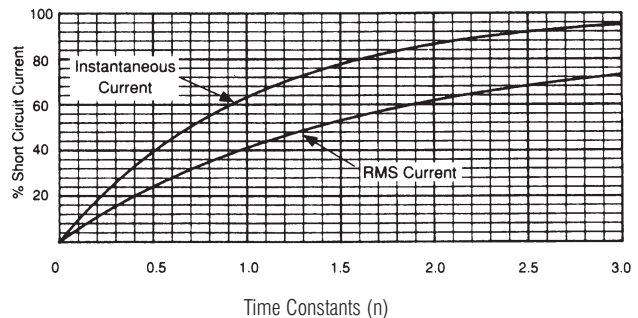

$$\text{Instantaneous Current (I inst)} = I_{sc} [1 - e^{-n}]$$

$$\text{RMS Current (I rms)} = I_{sc} \sqrt{\frac{1}{n} + \frac{2e^{-n}}{n} - \frac{e^{-2n}}{2n} - \frac{1.5}{n}}$$

Where I<sub>sc</sub> = short circuit current, n = number of time constants

Example.

Given: Voltage = 600VDC  
 Circuit Resistance (R) = 0.1 ohm  
 Circuit Inductance (L) = 1.0 x 10<sup>-3</sup> henry

$$I_{sc} = \frac{600 \text{ Volts}}{0.1 \text{ ohm}} = 6000 \text{ Amperes}$$

$$t \text{ (time constant)} = L/R = \frac{1.0 \times 10^{-3} \text{ henry}}{0.1 \text{ ohm}} = .01 \text{ second}$$

In the example, if a short circuit occurs, the instantaneous current will rise to .63 x 6000 = 3780 amperes in .01 second (one time constant). In .05 second (5 time constants) the short-circuit current will reach its ultimate value of 6000 amperes.



# APPLICATION INFORMATION

## DC CIRCUIT PROTECTION (Continued)

### Typical Time Constants

The time constant of a circuit is a function of the resistance and inductance of the components in the circuit. Here are typical time constants associated with the different DC voltage sources:

Less than 10 milliseconds	Battery supply of capacitor bank
Less than 25 milliseconds	Bridge circuit
10 to 40 milliseconds	Armature circuit of DC motor
1 second*	Field winding of DC motor

\* Where time constants exceed 100 milliseconds, we do not recommend the use of fuses. A fuse can be used to interrupt short circuits in these cases, but only under conditions where the inductance (load) is effectively by-passed.

Maximum parallel conductor inductance can be assumed to be less than  $.5 \times 10^{-6}$  henry per foot of conductor. Graph B approximates conductor inductance based on conductor size and spacing.

### Conductor End Views

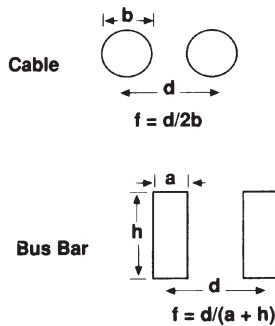

### Graph B- Conductor Inductance

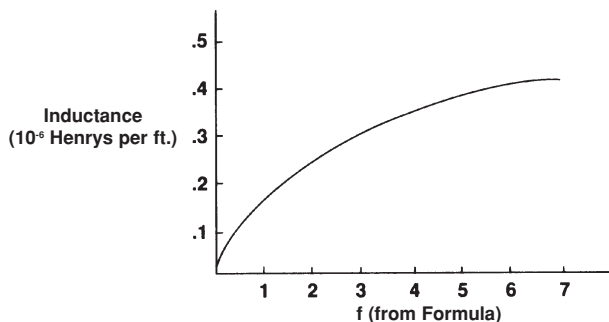

### Third Party Approval/Listing

Underwriters Laboratories and the Mine Safety and Health Administration (MSHA) are third party organizations which test and list or approve fuses for DC application, respectively.

Two UL standards exist for the DC rating of fuses. UL 248, entitled *Low Voltage Fuses* which provides for both AC and DC rating of UL class fuses in accordance with the Code. The previous standard U/L 198L has been absorbed into U/L 24B. UL 198M, entitled *Mine-Duty Fuses* addresses the DC rating of Class R and Class K fuses intended for the short circuit.

protection of trailing cables in mines. UL198M is equivalent to the requirements of MSHA, which are administered by the United States Department of Labor. The MSHA requirements for approval of DC rated fuses are specified in the Code of Federal Regulations, Title 30, Part 28.

Table 1 shows the voltage ratings and time constants associated with these standards.

Ferraz Shawmut fuses which have been tested and rated for DC by third party certification agencies are shown in Table 2 and Table 3. The Ferraz Shawmut Applications Engineering Department should be contacted for assistance with applications not served by these products.

**Table 1- DC Parameters of UL and MSHA Standards**

STANDARD	VOLTAGE	TIME CONSTANT	TEST CURRENT
UL248	Up to 600V DC	.01 second	10kA or higher
MSHA & UL198M	300 or 600V DC	.016 second .008 second .006 second .002 second	10kA or higher 1kA to 9.99kA 100A to 999A Less than 100A

**Table 2- DC Ratings of General Purpose Shawmut Fuses**

FUSE	FUSE AMPERE RATING	DC VOLTAGE	INTERRUPTING RATING	LISTING OR APPROVAL
ATM	0 to 30A	500V	100kA	UL 248-14
TRS-RDC	35 to 400A	600V	20kA	MSHA
A4BQ	601 to 3000A	500V	100kA	UL 248-10
TRS-R	0 to 12A	600V	20kA	UL 248-12
TRS-R	15 to 60A	300V	20kA	UL 248-12
TRS-R	70 to 600A	600V	100kA	UL 248-12
AJT	1 TO 600	500V	100kA	UL 248-8
A3T	1 to 1200	160V	50kA	UL 248-15
A6T	1 TO 800	300V	100kA	UL 248-15
ATDR	1/4 TO 30	300V	100kA	UL 248-4

**Table 3-DC Voltage Ratings of Component Recognized Shawmut Fuses\***

CATALOG NUMBER	FUSE AMPERE RATING	DC VOLTAGE	INTERRUPTING RATING
A13X	70 TO 2000A	100V	10kA
A50P	35 TO 800 A	450V	79kA
A50QS	70 TO 600A	500V	87kA
A70P	10 TO 800A	650V	100kA
A70Q	35 TO 600A	650V	100kA
A2Y Type 1	1 TO 60A	500V	100kA
A2Y Type 3	70 TO 600A	500V	100kA
A5Y, A6Y Types 1, 11	1 to 60A	500V	100kA
A5Y, A6Y, Types 3, 21	70 TO 600A	500V	100kA
A60Q	5-40A	600V	100kA
A70QS	35-800	700V	100kA

\*UL Recognized Components complying with UL198L DC requirements.

# APPLICATION INFORMATION

## LET-THRU CURRENT AND $I^2t$

Current limitation is one of the important benefits provided by modern fuses. Current-limiting fuses are capable of isolating a faulted circuit before the fault current has sufficient time to reach its maximum value. This current-limiting action provides several benefits:

- It limits thermal and mechanical stresses created by the fault currents.
- It reduces the magnitude and duration of the system voltage drop caused by fault currents.
- Current-limiting fuses can be precisely and easily coordinated under even short circuit conditions to minimize unnecessary service interruption.

Peak let-thru current ( $I_p$ ) and  $I^2t$  are two measures of the degree of current limitation provided by a fuse. Maximum allowable  $I_p$  and  $I^2t$  values are specified in UL standards for all UL listed current-limiting fuses, and are available on all semiconductor fuses.

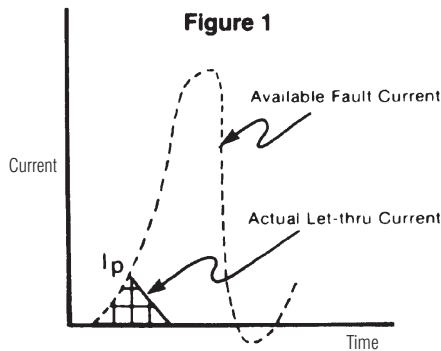

### Let-Thru Current

Let-thru current is that current passed by a fuse while the fuse is interrupting a fault within the fuse's current-limiting range. Figure 1 illustrates this. Let-thru current is expressed as a peak instantaneous value ( $I_p$ ).

### $I_p$

$I_p$  data is generally presented in the form of a graph. Let's review the key information provided by a peak let-thru graph. Figure 2 shows the important components.

- (1) The X-axis is labeled "Available Fault Current" in RMS symmetrical amperes.
- (2) The Y-axis is labeled as "Instantaneous Peak Let-Thru Current" in amperes.
- (3) The line labeled "Maximum Peak Current Circuit Can Produce" gives the worst case peak current possible with no fuse in the circuit.
- (4) the fuse characteristic line is a plot of the peak let-thru currents which are passed by a given fuse at various available fault currents.

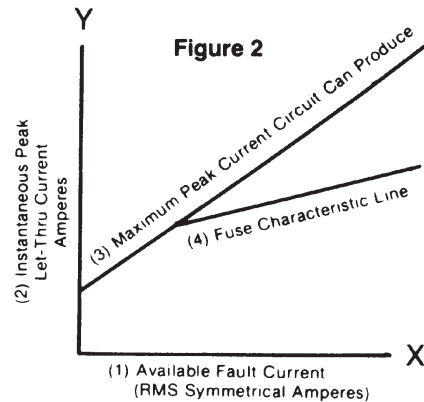
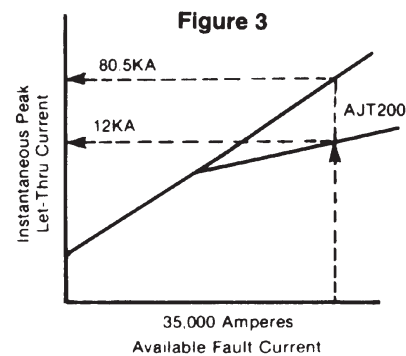

Figure 3 illustrates the use of the peak let-thru current graph. Assume that a 200 ampere Class J fuse (#AJT200) is to be applied where the available fault current is 35,000 amperes RMS. The graph shows that with 35,000 amperes RMS available, the peak available current is 80,500 amperes ( $35,000 \times 2.3$ ) and that the fuse will limit the peak let-thru current to 12,000 amperes.

Why is the peak available current is 2.3 times greater than the RMS available current. In theory the peak available fault current can be anywhere from  $1.414 \times$  (RMS available) to  $2.828 \times$  (RMS available) in a circuit where the impedance is all reactance with no resistance. In reality all circuits include some resistance and the 2.3 multiplier has been chosen as a practical limit.



# APPLICATION INFORMATION

## LET-THRU CURRENT AND $I^2t$ (Continued)

### $I_p$ versus $I^2t$

$I_p$  has a rather limited application usefulness. Two fuses can have the same  $I_p$  but different total clearing times. See Figure 4.

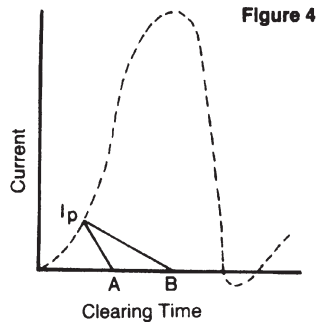

The fuse that clears in time A will provide better component protection than will the fuse that clears in time B.

Fuse clearing  $I^2t$  takes into account  $I_p$  and total clearing time. Fuse clearing  $I^2t$  values are derived from oscillograms of fuses tested within their current-limiting range and are calculated as follows:

$$I^2t = \int_0^t i^2 dt$$

The “t” in the equation is the total clearing time for the fuse. To be proper,  $I^2t$  should be written as  $(I_{RMS})^2t$ . It is generally understood that the “I” in  $I^2t$  is really  $I_{RMS}$ , and the RMS is dropped for the sake of brevity.

Note, from Figure 4, since clearing time “B” is approximately twice clearing time “A”, the resultant  $I^2t$  for that fuse will be at least twice the  $I^2t$  for the fuse with clearing time “A” and its level of protection will be correspondingly lower.

The  $I^2t$  passed by a given fuse is dependent upon the characteristics of the fuse and upon the applied voltage. The  $I^2t$  passed by a given fuse will decrease as the application voltage decreases. Unless stated otherwise, published  $I^2t$  values are based on AC testing. The  $I^2t$  passed by a fuse in a DC application may be higher or lower than in an AC application. The voltage, available fault current and time constant of the DC circuit are the determining factors.

Fuse  $I^2t$  value can be used to determine the level of protection provided to circuit components under fault current conditions. Manufacturers of diodes, thyristors, triacs, and cable publish  $I^2t$  withstand ratings for their products. The fuse chosen to protect these products should have a clearing  $I^2t$  that is lower than the withstand  $I^2t$  of the device being protected.

## FUSE LET-THRU TABLES

### Apparent RMS Symmetrical Let-Thru Current

Although the current-limiting characteristics of current-limiting fuses are represented in Peak Let-Thru **charts**, an increasingly easy to use method of presenting this data uses Peak Let-Thru **tables**. The tables are based on Peak Let-Thru charts and reflect fuse tests at 15% power factor at rated voltage with prospective fault currents as high as 200,000 amperes. At each prospective fault current, let-thru data is given in two forms for an individual fuse -  $I_{rms}$  and  $I_p$ . Where  $I_{rms}$  is the “Apparent RMS Symmetrical Current” and  $I_p$  is the maximum peak instantaneous current passed by the fuse, the  $I_p$  let-thru current is 2.3 times  $I_{rms}$ . This relationship exists between peak current and RMS available current under worst-case test conditions (i.e. closing angle of  $0^\circ$  at 15% power factor).

Let-thru tables are easier to read than let-thru charts. Presenting let-thru data in table versus chart format reduces the possibility of misreading the information and saves time. These tables are also helpful when comparing the current-limiting capability of various fuses.

# APPLICATION INFORMATION

## FUSE LET-THRU TABLES

**Table 1 - Class L, A4BQ Fuses at 600 Volts AC, 15% Power Factor**

PROSPECTIVE SHORT CIRCUIT RMS. SYM AMPERES	FUSE LET-THRU CURRENT IN KILO-AMPERES BY FUSE RATING IN AMPERES																					
	601		800		1000		1200		1600		2000		2500		3000		4000		5000		6000	
	irms	lp	irms	lp	irms	lp	irms	lp	irms	lp	irms	lp	irms	lp	irms	lp	irms	lp	irms	lp	irms	lp
10,000	7.4	17	8.7	20	10	23	10	23	10	23	10	23	10	23	10	23	10	23	10	23	10	23
15,000	8.3	19	10	23	12	27	13	30	15	35	15	35	15	35	15	35	15	35	15	35	15	35
20,000	9.1	21	11	25	13	29	14	33	17	39	20	46	20	46	20	46	20	46	20	46	20	46
25,000	9.8	23	12	27	13	31	15	35	18	42	22	50	25	58	25	58	25	58	25	58	25	58
30,000	10	24	13	29	14	33	16	37	20	45	23	53	29	66	30	69	30	69	30	69	30	69
35,000	11	25	13	30	15	35	17	39	20	47	24	56	30	69	35	81	35	81	35	81	35	81
40,000	12	27	14	32	16	37	18	41	21	49	25	58	31	72	36	83	40	92	40	92	40	92
50,000	13	29	15	34	17	40	19	44	23	53	27	63	34	78	39	89	48	111	50	115	50	115
60,000	13	30	16	36	18	42	20	47	25	57	29	67	36	83	41	94	51	118	60	138	60	138
80,000	14	33	17	40	20	46	23	52	27	62	32	73	40	91	45	104	57	130	67	153	77	176
100,000	16	36	19	43	22	50	24	56	29	67	34	79	43	98	49	112	61	140	72	165	83	190
150,000	18	41	21	49	25	57	28	64	33	77	39	90	49	112	56	128	70	160	82	189	94	217
200,000	20	45	24	54	27	63	31	71	37	84	43	100	53	123	61	141	77	176	90	208	104	239

**Table 2 - Class L, A4BY Fuses at 600 Volts AC, 15% Power Factor**

PROSPECTIVE SHORT CIRCUIT RMS. SYM AMPERES	FUSE LET-THRU CURRENT IN KILO-AMPERES BY FUSE RATING IN AMPERES																	
	601		800		1000		1200		1600		2000		2500		3000		4000	
	irms	lp	irms	lp	irms	lp	irms	lp	irms	lp	irms	lp	irms	lp	irms	lp	irms	lp
15,000	11	24	13	29	15	35	15	35	15	35	15	35	15	35	15	35	15	35
20,000	12	26	14	32	16	37	19	43	20	46	20	46	20	46	20	46	20	46
25,000	13	29	15	34	18	40	20	46	24	55	25	58	25	58	25	58	25	58
30,000	13	30	16	36	19	43	21	49	25	58	29	67	30	69	30	69	30	69
35,000	14	32	17	38	20	45	23	52	27	61	30	70	33	76	35	81	35	81
40,000	15	34	17	40	21	47	24	54	28	64	32	73	35	79	37	86	40	92
50,000	16	36	19	43	22	51	25	58	30	68	34	78	37	86	41	95	50	115
60,000	17	38	20	45	24	54	27	62	31	72	37	84	40	91	44	100	53	121
80,000	18	42	22	50	26	59	29	67	35	80	40	92	44	100	48	110	58	133
100,000	20	45	24	54	28	64	32	73	38	87	43	99	47	108	52	119	62	143
150,000	23	52	27	62	32	73	37	84	43	99	49	113	54	123	59	137	73	167
200,000	25	56	29	67	35	80	40	91	48	110	54	123	59	136	65	150	79	181

**Table 3 - Class L, A4BT Fuses at 600 Volts AC, 15% Power Factor**

PROSPECTIVE SHORT CIRCUIT RMS. SYM AMPERES	FUSE LET-THRU CURRENT IN KILO-AMPERES BY FUSE RATING IN AMPERES									
	800		1000		1200		1600		2000	
	irms	lp	irms	lp	irms	lp	irms	lp	irms	lp
15,000	14	33	15	35	15	35	15	35	15	35
20,000	16	36	18	41	20	46	20	46	20	46
25,000	17	39	19	45	22	50	25	58	25	58
30,000	18	41	21	48	23	54	28	63	30	69
35,000	19	43	22	50	25	56	29	67	34	79
40,000	20	45	23	52	26	59	30	70	35	81
50,000	21	49	25	56	28	63	33	75	38	87
60,000	23	52	26	60	29	67	35	80	40	93
80,000	25	57	29	66	32	74	38	88	44	102
100,000	27	62	31	71	35	80	41	95	48	110
150,000	31	70	35	81	40	92	47	109	55	126
200,000	34	78	39	89	44	101	52	120	60	139



# APPLICATION INFORMATION

## FUSE LET-THRU TABLES (Continued)

### Apparent RMS Symmetrical Let-Thru Current

**Table 4 - Class RK1, A6K Fuses at 600 Volts AC, 15% Power Factor**

PROSPECTIVE SHORT CIRCUIT RMS. SYM AMPERES	FUSE LET-THRU CURRENT IN KILO-AMPERES											
	BY FUSE RATING IN AMPERES											
	30		60		100		200		400		600	
	irms	lp	irms	lp	irms	lp	irms	lp	irms	lp	irms	lp
5,000	.63	1.4	1.4	3.2	2.0	4.6	3.2	7.4	4.6	11	5.0	11.5
10,000	.80	1.8	1.7	3.9	2.6	6.0	4.0	9.2	5.8	13	7.5	17
15,000	.91	2.1	2.0	4.6	2.9	6.7	4.6	11	6.7	15	8.6	20
20,000	1.0	2.3	2.2	5.1	3.2	7.4	5.0	12	7.4	17	9.5	22
25,000	1.1	2.5	2.4	5.5	3.5	8.1	5.4	12	7.9	18	10	23
30,000	1.2	2.6	2.5	5.8	3.7	8.5	5.8	13	8.4	19	11	25
35,000	1.2	2.8	2.6	6.0	3.9	9.0	6.1	14	8.9	20	11	26
40,000	1.3	2.9	2.8	6.4	4.1	9.4	6.3	14	9.3	21	12	27
50,000	1.4	3.1	3.0	6.9	4.4	10	6.8	16	10	23	13	30
60,000	1.4	3.3	3.2	7.4	4.7	11	7.3	17	11	24	14	32
80,000	1.6	3.7	3.5	8.1	5.1	12	8.0	18	12	27	15	35
100,000	1.7	3.9	3.7	8.5	5.5	13	8.6	20	13	29	16	37
150,000	2.0	4.5	4.4	9.9	6.3	14	9.9	23	14	33	19	43
200,000	2.2	4.9	4.7	11	7.0	16	11	25	16	37	20	47

**Table 5 - Class RK1,A6D Fuses at 600 Volts AC, 15% Power Factor**

PROSPECTIVE SHORT CIRCUIT RMS. SYM AMPERES	FUSE LET-THRU CURRENT IN KILO-AMPERES											
	BY FUSE RATING IN AMPERES											
	30		60		100		200		400		600	
	irms	lp	irms	lp	irms	lp	irms	lp	irms	lp	irms	lp
5,000	.80	1.8	1.5	3.5	2.0	4.6	3.5	8.0	5.0	12	-	-
10,000	1.0	2.3	1.9	4.4	2.5	5.8	4.4	10.1	7.1	16.4	10	23
15,000	1.2	2.7	2.2	4.9	2.9	6.6	5.0	11.6	8.2	18.8	12	27
20,000	1.3	2.9	2.4	5.4	3.1	7.1	5.5	12	9.0	20.7	13	29
25,000	1.4	3.2	2.6	5.9	3.4	7.8	6.0	13.8	9.7	22.3	14	32
30,000	1.5	3.4	2.7	6.2	3.6	8.3	6.3	14.6	10.3	23.6	15	33
35,000	1.5	3.5	2.9	6.6	3.8	8.7	6.7	15.4	10.8	24.9	15	35
40,000	1.6	3.7	3.0	6.9	4.0	9.1	7.0	16.5	11.3	26	16	37
50,000	1.7	4.0	3.2	7.4	4.3	9.8	7.5	16.5	12.2	28	17	40
60,000	1.8	4.2	3.4	7.8	4.5	11.0	8.0	17	13	30	18	42
80,000	2.0	4.7	3.8	8.6	5.0	12	8.8	20.3	13	33	20	46
100,000	2.2	5.0	4.1	9.3	5.4	12	9.5	20	14	35	22	50
150,000	2.5	5.8	4.6	11	6.1	14	10.9	25	16	40	25	57
200,000	2.8	6.3	5.1	12	6.8	16	11	25	19	45	27	63

**Table 6 - Class J, A4J Fuses at 600 Volts AC, 15% Power Factor**

PROSPECTIVE SHORT CIRCUIT RMS. SYM AMPERES	FUSE LET-THRU CURRENT IN KILO-AMPERES											
	BY FUSE RATING IN AMPERES											
	30		60		100		200		400		600	
	irms	lp	irms	lp	irms	lp	irms	lp	irms	lp	irms	lp
5,000	.85	2.0	1.4	3.2	2.0	4.6	3.1	7.2	4.5	10	5.0	12
10,000	1.1	2.5	1.8	4.4	2.8	6.4	3.6	8.2	5.7	13	8.7	20
15,000	1.2	2.8	2.0	4.6	2.9	6.6	4.1	9.4	6.5	15	9.9	23
20,000	1.4	3.1	2.4	5.1	3.2	7.3	4.5	10	7.1	16	11	25
25,000	1.5	3.4	2.4	5.5	3.8	8.7	5.3	12	7.7	18	12	27
30,000	1.6	3.6	2.5	5.8	4.0	9.2	5.5	13	8.2	19	13	29
35,000	1.6	3.7	2.7	6.2	4.2	9.7	5.9	14	8.6	20	13	30
40,000	1.7	3.9	2.8	6.4	4.5	10	6.0	14	9.0	21	14	32
50,000	1.8	4.2	3.0	6.9	4.7	11	6.1	14	9.7	22	15	34
60,000	2.0	4.5	3.2	7.4	5.0	11	6.5	15	10	23	16	36
80,000	2.2	4.9	3.5	8.1	5.5	12	7.1	16	11	25	17	40
100,000	2.3	5.3	3.8	9.5	6.0	14	7.7	18	12	28	19	43
150,000	2.7	6.1	4.7	10.9	6.8	16	8.8	20	14	32	21	49
200,000	2.9	6.7	4.8	11	7.5	17	9.7	22	15	35	24	54

# APPLICATION INFORMATION

## FUSE LET-THRU TABLES (Continued)

### Apparent RMS Symmetrical Let-Thru Current

**Table 7 - Class J, AJT Fuses at 600 Volts AC, 15% Power Factor**

PROSPECTIVE SHORT CIRCUIT RMS. SYM AMPERES	FUSE LET-THRU CURRENT IN KILO-AMPERES											
	BY FUSE RATING IN AMPERES											
	30		60		100		200		400		600	
	irms	lp	irms	lp	irms	lp	irms	lp	irms	lp	irms	lp
5,000	.79	1.8	1.2	2.8	1.8	4.0	3.1	7.0	4.8	11	5.0	12
10,000	1.0	2.3	1.6	3.6	2.2	5.1	3.8	8.8	6.0	14	8.3	19
15,000	1.2	2.6	1.8	4.1	2.5	5.8	4.4	10	6.9	16	9.5	22
20,000	1.3	2.9	2.0	4.5	2.8	6.4	4.8	11	7.6	18	11	24
25,000	1.4	3.1	2.1	4.8	3.0	6.9	5.2	12	8.2	19	11	26
30,000	1.4	3.3	2.2	5.1	3.2	7.4	5.5	13	8.7	20	12	28
35,000	1.5	3.5	2.4	5.4	3.4	7.7	5.8	13	9.1	21	13	29
40,000	1.6	3.7	2.5	5.6	3.5	8.1	6.1	14	9.6	22	13	30
50,000	1.7	3.9	2.7	6.1	3.8	8.7	6.6	15	10.3	24	14	33
60,000	1.8	4.2	2.8	6.4	4.0	9.2	7.0	16	11	25	15	35
80,000	2.0	4.6	3.1	7.1	4.4	10	7.7	18	12	28	17	38
100,000	2.2	4.9	3.3	7.6	4.8	11	8.3	19	13	30	18	41
150,000	2.5	5.7	3.8	8.7	5.4	12	9.5	22	15	34	21	47
200,000	2.7	6.2	4.2	9.7	6.0	14	10.4	24	16	37	23	59

**Table 8 - Class T, A6T Fuses at 600 Volts AC, 15% Power Factor**

PROSPECTIVE SHORT CIRCUIT RMS. SYM AMPERES	FUSE LET-THRU CURRENT IN KILO-AMPERES													
	BY FUSE RATING IN AMPERES													
	30		60		100		200		400		600		800	
	irms	lp	irms	lp	irms	lp	irms	lp	irms	lp	irms	lp	irms	lp
5,000	.62	1.4	1.2	2.8	1.6	3.8	2.6	6.0	4.2	9.7	5.0	12	5.0	12
10,000	.78	1.8	1.5	3.5	2.1	4.8	3.3	7.5	5.3	12	8.2	19	10	22
15,000	.89	2.1	1.7	4.0	2.4	5.4	3.7	8.6	6.1	14	9.4	22	11	26
20,000	.98	2.3	1.9	4.4	2.6	6.0	4.1	9.5	6.7	15	10	24	12	28
25,000	1.1	2.4	2.0	4.8	2.8	6.5	4.4	10	7.2	17	11	26	13	31
30,000	1.1	2.6	2.2	5.0	3.0	6.9	4.7	11	7.7	18	12	27	14	32
35,000	1.2	2.7	2.3	5.3	3.1	7.2	5.0	11	8.1	19	12	29	15	34
40,000	1.2	2.9	2.4	5.6	3.3	7.5	5.2	12	8.5	19	13	30	16	36
50,000	1.3	3.1	2.6	6.0	3.5	8.1	5.6	13	9.1	21	14	32	17	38
60,000	1.4	3.3	2.8	6.4	3.8	8.6	5.9	14	9.7	22	15	34	18	41
80,000	1.6	3.6	3.0	7.0	4.1	9.5	6.5	15	11	25	16	38	20	45
100,000	1.7	3.9	3.2	7.5	4.5	10	7.0	16	11	26	18	40	21	48
150,000	1.9	4.4	3.8	8.6	5.1	12	8.1	19	13	30	20	46	24	55
200,000	2.1	4.9	4.1	9.5	5.6	13	8.9	20	14	33	22	51	27	61

**Table 9 - Class T, A3T Fuses at 300 Volts AC, 15% Power Factor**

PROSPECTIVE SHORT CIRCUIT RMS. SYM AMPERES	FUSE LET-THRU CURRENT IN KILO-AMPERES															
	BY FUSE RATING IN AMPERES															
	30		60		100		200		400		600		800		1200	
	irms	lp	irms	lp	irms	lp	irms	lp	irms	lp	irms	lp	irms	lp	irms	lp
5,000	.53	1.2	.95	2.2	1.4	3.1	2.0	4.6	3.0	6.9	4.5	10	5.0	12	5.0	12
10,000	.66	1.5	1.2	2.8	1.7	3.9	2.5	5.8	3.8	8.7	5.6	13	7.2	16	9.3	21
15,000	.76	1.7	1.4	3.2	2.0	4.5	2.9	6.6	4.4	10	6.4	15	8.2	19	11	24
20,000	.83	1.9	1.5	3.5	2.1	4.8	3.1	7.1	4.8	11	7.0	16	9.0	21	12	27
25,000	.90	2.1	1.6	3.7	2.3	5.3	3.4	7.8	5.2	12	7.6	17	9.7	22	13	29
30,000	.96	2.2	1.7	3.9	2.5	5.6	3.6	8.3	5.5	13	8.1	19	10	24	13	31
35,000	1.0	2.3	1.8	4.1	2.6	6.0	3.8	8.7	5.8	13	8.5	20	11	25	14	32
40,000	1.1	2.4	1.9	4.4	2.7	6.2	4.0	9.2	6.0	14	8.9	20	11	26	15	34
50,000	1.1	2.6	2.1	4.7	2.9	6.7	4.3	9.9	6.5	15	9.6	22	12	28	16	37
60,000	1.2	2.8	2.2	5.1	3.1	7.1	4.5	10	6.9	16	10	23	13	30	17	39
80,000	1.3	3.1	2.4	5.5	3.4	7.8	5.0	12	7.6	17	11	26	14	33	19	43
100,000	1.4	3.3	2.6	6.0	3.7	8.4	5.4	12	8.2	19	12	28	15	35	20	46
150,000	1.6	3.7	3.0	6.8	4.2	9.7	6.1	14	9.4	22	14	32	18	41	23	53
200,000	1.8	4.1	3.3	7.5	4.6	11	6.8	16	10	24	15	35	19	45	25	58



# APPLICATION INFORMATION

## FUSE LET-THRU TABLES (Continued)

### Apparent RMS Symmetrical Let-Thru Current

**Table 10- Class RK1, A2K Fuses at 250 Volts AC, 15% Power Factor**

PROSPECTIVE SHORT CIRCUIT RMS, SYM AMPERES	FUSE LET-THRU CURRENT IN KILO-AMPERES											
	BY FUSE RATING IN AMPERES											
	30		60		100		200		400		600	
	irms	lp	irms	lp	irms	lp	irms	lp	irms	lp	irms	lp
5,000	.61	1.4	1.4	3.2	1.7	4.0	2.9	6.7	4.4	10	5.0	12
10,000	.77	1.8	1.7	4.0	2.2	5.0	3.7	8.5	5.5	13	7.4	17
15,000	.88	2.0	2.0	4.6	2.5	5.8	4.2	9.7	6.3	14	8.5	19
20,000	.97	2.2	2.2	5.0	2.8	6.3	4.6	11	6.9	16	9.3	21
25,000	1.1	2.4	2.4	5.4	3.0	6.8	5.0	12	7.4	17	10	23
30,000	1.1	2.6	2.5	5.8	3.2	7.3	5.3	12	7.9	18	11	25
35,000	1.2	2.7	2.6	6.0	3.3	7.7	5.6	13	8.3	19	11	26
40,000	1.2	2.8	2.8	6.3	3.5	8.0	5.9	13	8.7	20	12	27
50,000	1.3	3.0	3.0	6.8	3.8	8.6	6.3	14	9.4	22	13	29
60,000	1.4	3.2	3.2	7.2	4.0	9.2	6.7	15	10	23	13	31
80,000	1.5	3.5	3.5	8.0	4.4	10	7.4	17	11	25	15	34
100,000	1.7	3.8	3.7	8.6	4.7	11	7.9	18	12	27	16	37
150,000	1.9	4.4	4.3	9.8	5.4	12	9.1	21	14	31	18	42
200,000	2.1	4.8	4.7	11	6.0	14	10	23	15	34	20	46

**Table 11 - Class RK1, A2D Fuses at 250 Volts AC, 15% Power Factor**

PROSPECTIVE SHORT CIRCUIT RMS, SYM AMPERES	FUSE LET-THRU CURRENT IN KILO-AMPERES											
	BY FUSE RATING IN AMPERES											
	30		60		100		200		400		600	
	irms	lp	irms	lp	irms	lp	irms	lp	irms	lp	irms	lp
5,000	.77	1.8	1.4	3.2	2.0	4.6	3.2	7.3	5.0	12	5.0	12
10,000	.97	2.2	1.8	4.0	2.5	5.8	4.0	9.2	6.4	15	8.0	18
15,000	1.1	2.6	2.0	4.6	2.9	6.6	4.6	11	7.3	17	9.2	21
20,000	1.2	2.8	2.2	5.1	3.2	7.3	5.0	12	8.1	19	10	23
25,000	1.3	3.0	2.4	5.5	3.4	7.9	5.4	12	8.7	20	11	25
30,000	1.4	3.2	2.5	5.8	3.6	8.3	5.8	13	9.2	21	12	27
35,000	1.5	3.4	2.7	6.1	3.8	8.8	6.1	14	9.7	22	12	28
40,000	1.5	3.5	2.8	5.7	4.0	9.2	6.4	15	10	23	13	29
50,000	1.7	3.8	3.0	6.9	4.3	9.9	6.8	16	11	25	14	32
60,000	1.8	4.0	3.2	7.3	4.6	11	7.3	17	12	27	15	34
80,000	1.9	4.5	3.5	8.1	5.0	12	8.0	18	13	29	16	37
100,000	2.1	4.8	3.8	8.7	5.4	12	8.6	20	14	32	17	40
150,000	2.4	5.5	4.3	9.9	6.2	14	9.9	23	16	36	20	46
200,000	2.6	6.0	4.8	11	6.8	16	11	25	17	40	22	50

**Table 12 - Class RK5, TRS Fuses at 600 Volts AC, 15% Power Factor**

PROSPECTIVE SHORT CIRCUIT RMS, SYM AMPERES	FUSE LET-THRU CURRENT IN KILO-AMPERES											
	BY FUSE RATING IN AMPERES											
	30		60		100		200		400		600	
	irms	lp	irms	lp	irms	lp	irms	lp	irms	lp	irms	lp
5,000	1.7	3.9	3.2	7.4	3.4	7.8	5.0	12	-	-	-	-
10,000	2.1	4.8	4.0	9.2	4.2	9.7	6.2	14	10	23	10	23
15,000	2.4	5.5	4.6	11	4.8	11	7.1	16	12	27	15	35
20,000	2.7	6.2	5.1	12	5.3	12	7.8	18	13	30	18	42
25,000	2.9	6.7	5.5	13	5.7	13	8.4	19	14	32	20	45
30,000	3.1	7.1	5.8	13	6.1	14	8.9	20	15	35	21	48
35,000	3.3	7.6	6.1	14	6.4	15	9.4	22	16	36	22	50
40,000	3.4	7.8	6.4	15	6.7	15	9.8	23	17	38	23	53
50,000	3.7	8.5	6.9	16	7.2	17	11	24	18	41	25	57
60,000	3.9	9.0	7.3	17	7.7	18	11	26	19	43	26	60
80,000	4.3	9.9	8.1	19	8.5	20	12	29	21	48	29	66
100,000	4.6	11	8.7	20	9.1	21	13	31	22	52	31	72
150,000	5.3	12	9.9	23	10	24	15	35	26	59	36	82
200,000	5.8	13	11	25	12	26	17	39	28	65	39	90

# APPLICATION INFORMATION

## FUSE LET-THRU TABLES (Continued)

### Apparent RMS Symmetrical Let-Thru Current

**Table 13 - Class RK5, TR Fuses at 250 Volts AC, 15% Power Factor**

PROSPECTIVE SHORT CIRCUIT RMS. SYM AMPERES	FUSE LET-THRU CURRENT IN KILO-AMPERES											
	BY FUSE RATING IN AMPERES											
	30		60		100		200		400		600	
	irms	Ip	irms	Ip	irms	Ip	irms	Ip	irms	Ip	irms	Ip
5,000	1.4	3.2	3.0	6.9	3.2	7.4	5.0	12	-	-	-	-
10,000	1.8	4.1	3.8	8.7	4.1	9.4	6.6	15	10	23	10	23
15,000	2.1	4.8	4.4	10	4.7	11	7.6	17	13	29	15	35
20,000	2.3	5.3	4.8	11	5.1	12	8.4	19	14	32	19	44
25,000	2.5	5.6	5.2	12	5.5	13	9.0	21	15	34	21	48
30,000	2.6	6.0	5.5	13	5.9	14	9.6	22	16	37	22	50
35,000	2.7	6.2	5.8	13	6.2	14	10	23	17	38	23	53
40,000	2.9	6.7	6.1	14	6.5	15	11	24	18	40	24	56
50,000	3.1	7.1	6.5	15	7.0	16	11	26	19	43	26	60
60,000	3.3	7.6	7.0	16	7.4	17	12	27	20	46	28	63
80,000	3.6	8.3	7.7	18	8.1	19	13	31	22	51	30	70
100,000	3.9	9.0	8.3	19	8.8	20	14	33	24	55	33	75
150,000	4.4	10	9.4	22	10	23	16	38	27	62	38	86
200,000	4.9	11	11	24	11	26	18	41	30	69	41	95

## BUS DUCT SHORT-CIRCUIT PROTECTION

Bus duct listed to the UL 857 standard is labeled with a “short-circuit current rating”. To earn this rating the bus duct must be capable of surviving its “short-circuit current rating” for 3 full cycles (60 Hz basis).

The following table shows the potential short-circuit current ratings for both feeder and plug-in bus duct. Also shown are the peak instantaneous currents the bus duct must be capable of withstanding to earn a given “short-circuit current rating”.

Current-limiting fuses may be used to protect bus duct from fault currents that exceed the bus duct “short-circuit current rating”. The fuse will provide short-circuit protection if fuse peak let-thru current does not exceed the bus duct peak instantaneous withstand current. In addition, the fuse total clearing curve must fall to the left of the bus duct short-circuit current rating at the 3 cycle (.05 sec.) point. The fuse ampere ratings shown in this table satisfy both of these requirements.

### Example:

In a 480V circuit with 100,000A available short-circuit current, what maximum size fuse can be used to protect feeder bus duct which has a 42,000 short-circuit rating?

### Answer:

From the table, A Ferraz Shawmut 1600A Class L fuse A4BQ1600 will protect this bus duct up to 100,000 amperes.

FEEDER & PLUG-IN BUS DUCT		MAXIMUM FERRAZ SHAWMUT FUSE FOR SHORT-CIRCUIT PROTECTION*		
Short Circuit Current Rating in Amperes	Peak Instantaneous Withstand Current in Amperes	50,000A	100,000A	200,000A
5000	8500	60A	60A	30A
7500	13,000	100A	100A	100A
10,000	17,000	200A	100A	100A
14,000	28,000	400A	400A	200A
22,000	48,000	800A	600A	400A
25,000	55,000	1000A	600A	600A
30,000	66,000	1200A	800A	600A
35,000	76,000	1600A	1000A	800A
42,000	92,000	2500A	1600A	1000A
50,000	110,000	3000A	2000A	1200A
65,000	142,000	4000A	3000A	2500A
75,000	160,000	5000A	4000A	3000A
85,000	180,000	5000A	5000A	4000A
100,000	220,000	6000A	6000A	5000A
125,000	270,000	6000A	6000A	6000A
150,000	330,000	6000A	6000A	6000A

\* 30A to 600A fuses – Class J (\*time delay AJT)  
Class RK1 (A2K/A6K or time delay A2D/A6D)

800 to 6000A fuses – Class L (A4BQ)



# APPLICATION INFORMATION

## CAPACITOR PROTECTION

The primary responsibility of a capacitor fuse is to isolate a shorted capacitor before the capacitor can damage surrounding equipment or personnel. Typical capacitor failure occurs when the dielectric in the capacitor is no longer able to withstand the applied voltage. A low impedance current path results. The excessive heat generated builds pressure and can cause violent case rupture. A fuse will isolate the shorted capacitor before case rupture occurs.

### Fuse Placement

The Code requires that an overcurrent device be placed in each ungrounded conductor of each capacitor bank (see Figure 1). The Code further requires that the rating or setting of the overcurrent device be as low as practicable. A separate overcurrent device is not required if the capacitor is connected on the load side of a motor-running overcurrent device.

Fusing per the Code provides reasonable protection if the capacitors are the metalized film self-healing type. If not, each capacitor should be individually fused as shown in Figure 2.

Fusing each individual capacitor is especially important in large banks of parallel capacitors. Should one capacitor fail, the parallel capacitors will discharge into the faulted capacitor and violent case rupture of the faulted capacitor can result. Individual capacitor fusing eliminates this problem.

If the capacitors are to be placed in banks comprised of both series and parallel combinations, the capacitor manufacturer must be consulted for fuse placement recommendations. The opening of improperly placed fuses can cause overvoltage and result in damage to other capacitors in the network.

### Ampere rating

How much overcurrent can a capacitor withstand? What effects do neighboring capacitors have on the inrush of a given capacitor? These and other questions influence fuse selection. Circuit analysis can be very complex. It is best to consult the capacitor manufacturer for specific recommendations.

In lieu of specific fusing recommendations from the capacitor manufacturer, we suggest a Shawmut A60C type 121 or an A6Y Type 2SG fuse sized at 165% to 200% of the capacitor's current rating. If these fuses are not dimensionally acceptable, then a non-time delay Class J or Class RK1 fuse could be used and sized at 185% to 220% of the capacitor's current rating.

Capacitor fuses are selected for their ability to provide short circuit protection and to ride through capacitor inrush current. Inrush current is affected by the closing angle, capacitance, resistance and inductance of the circuit, and varies from one application to another. Inrush lasts for less than 1/4 cycle and is typically less than ten times the capacitor's current rating.

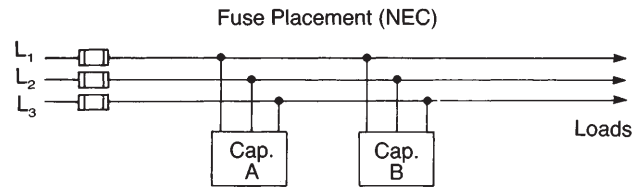

Figure 1

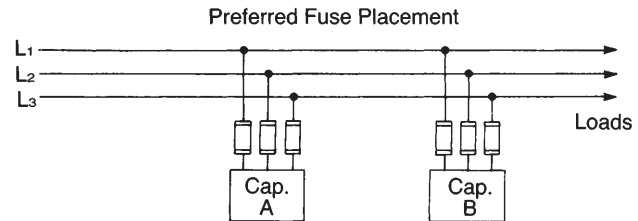

Figure 2

Steady state capacitor current is proportional to the applied voltage and frequency. Since voltage and frequency are fixed in power factor correction applications, the capacitor is not expected to be subjected to an overload. Therefore, capacitor fuses are not selected to provide overload protection for the capacitor.

### KVAR vs. AMPS

The capacitor's current rating can be derived from its KVAR rating by using the following formula:

$$\frac{\text{KVAR} \times 1000}{\text{volts}} = \text{amps} \quad 1 \text{ KVAR} = 1000\text{VA (Reactive)}$$

**Example:** What fuse would you recommend for a three phase capacitor rated 100KVAR at 480 volts?

$$\frac{100,000 \text{ volt-amps}}{480 \text{ volts}} = 208 \text{ amps}$$

To determine line current, we must divide the 208 amps, which is the three phase current by  $\sqrt{3}$

$$\frac{208}{\sqrt{3}} = 120 \text{ amps}$$

If an A60C Type 121 fuse is to be used, size the fuse at 165% to 200% of line current.

$$\begin{aligned} 120 \text{ amps} \times 1.65 &= 198 \text{ amps} \\ 120 \text{ amps} \times 2.00 &= 240 \text{ amps} \end{aligned}$$

**Suggestions:** A60C200-121 or A60C200-121TI

If a Class J or a Class RK1 is to be used, size the fuse at 185% to 220% of line current.

$$\begin{aligned} 120 \text{ amps} \times 1.85 &= 222 \text{ amps} \\ 120 \text{ amps} \times 2.20 &= 264 \text{ amps} \end{aligned}$$

**Suggestions:** A4J225 or A6K225R

# APPLICATION INFORMATION

## CABLE PROTECTION

### Using Cable Protectors





Cable Protectors are special purpose limiters which are used to protect service entrance and distribution cable runs. Though not required by the Code for overcurrent protection, the Code does recognize the use of Cable Protector as current limiting devices.

When unprotected cables are paralleled, a single conductor faulting to ground can result in damage to and eventual loss of all parallel conductors. The resultant cost of cable replacement, loss of service, and down time can be significant. This cost can be minimized by the use of Cable Protectors.

When each phase consists of three or more parallel conductors, Cable Protectors are installed at each end of each conductor. Should one cable fault, the Cable Protectors at each end of the faulted cable will open and isolate the faulted cable. The unfaulted cables will maintain service.

### Terminations

In addition to improving system reliability, Cable Protectors provide a means of terminating cable, thus eliminating the need for cable lugs. Cable Protectors are available with the following configurations:

- Cable to cable  Type 1
- Cable to offset bus  Type 3
- Bus to offset bus  Type 5
- Mole to cable  Type 6
- Mole to offset bus  Type 8

Aluminum and copper cable require different terminations. Cable Protectors intended for copper cable must not be used with aluminum cable. Cable Protectors intended for aluminum cable include an oxide inhibitor and can be used on either aluminum or copper cable.

### Placement of Cable Protectors

In single phase applications where a single transformer supplies the service and there are only one or two conductors per phase, a single Cable Protector per cable may be used. The Cable Protector should be located at the supply end of the cable. In all other applications, Cable Protectors should be placed at both ends of each cable. This allows a faulted cable to be isolated from the source end and from a back feed at its load end. Isolation of a faulted cable is only possible if there are 3 or more parallel cables per phase.

### Cable Protector Ampacity

Cable Protectors are not ampere rated. They are not intended to provide overload protection for the cable. Cable Protectors are designed to open in case of a short circuit or after a cable has faulted. Thus total system reliability is maximized. For these reasons Cable Protectors are rated in terms of the cable material (aluminum or copper) and the cable cable size (250kcmil, 500kcmil, etc.)

### Selecting a Cable Protector

The following questions must be answered to choose the correct Cable Protector:

- Is the cable copper or aluminum?
- What is the cable size?
- What termination type is desired?
- Is the Cable Protector to be insulated or protected with a heat-shrink sleeve or a rubber boot?

Once these questions have been answered, the Cable Protector catalog number can be chosen from the listings.

### Small Cable Sizes

Class J fuses may be used for cable sizes smaller than 4/0. Since Class J blades are drilled for bolting, they may be attached directly to bus. Cables must be prepared by installing lugs before bolting to the fuse. Cable-to-bus or cable-to-cable terminations are possible. The following ampere ratings are recommended, for each cable size.

CABLE - SIZE AWG CU or AL	CLASS J FUSE CATALOG NUMBER
#4	A4J125
#3	A4J150
#2	A4J175
#1	A4J200
1/0	A4J250
2/0	A4J300
3/0	A4J400



# APPLICATION INFORMATION

---

## WELDER PROTECTION

### General

Articles 630-12 and 630-32 of the National Electrical Code requires that electric welders and their supply conductors have overcurrent protection. The Code further requires that each welder have a nameplate which provides information necessary for the selection of the appropriate supply conductors and overcurrent protection devices.

While either circuit breakers or fuses may be used for overcurrent protection, the typically high available fault currents and the need for overall system selective coordination favor the use of current-limiting fuses.

### Supply Conductor Protection

For AC transformer, DC rectifier and motor-generator arc welders the supply conductors should be fused at not more than 200% of the conductor ampere rating. For resistance welders the Code allows fusing at up to 300% of conductor ampere rating. In both applications a time delay RK5 fuse such as the Tri-onic<sup>®</sup> is generally recommended.

### Welder Protection

To comply with the Code, AC transformer, DC rectifier and motor-generator arc welders should be fused at not more than 200% of their primary current rating (shown on welder nameplate). Resistance welders should be fused at not more than 300% of their primary current rating. As with supply conductors, RK5 time delay fuses such as the Tri-onic<sup>®</sup> are recommended. It should be noted that the Code states that a separate overcurrent device is not required for the welder if the supply conductors are protected by an overcurrent device which will satisfy the welder overcurrent protection requirements.

### Special Applications

UL class fuses sized according to the Code may not be suitable in some welding applications. High ambient temperatures, high cycle rates and high available fault currents may require the use of Ferraz Shawmut Welder Protectors.

Welder Protectors (A4BX Type 150 or Type 150J) are special purpose limiters which have been designed specifically for welding applications to protect equipment in case of short circuits. They have twice the thermal rating of UL Class fuses yet provide a low clearing  $I^2t$ . This combination minimizes fuse fatigue and allows effective coordination with upstream devices. Welder Protectors may be sized closer to welder primary ampere rating than UL Class fuses, hence may allow the use of smaller disconnect switches.

Welder Protectors are intended for short circuit protection and are not intended for overload protection. They should never be used as the only protective device on any welder application. Thermal overload protection must be provided in the welder by some other device.

# APPLICATION INFORMATION

## SELECTIVITY BETWEEN 240, 480 OR 600 VOLT MAIN AND BRANCH FUSES

### Definition

Coordination is defined as properly localizing a fault condition to restrict outages to the equipment affected, accomplished by choice of selective fault protective devices.

Coordination (selectivity, discrimination) is desirable and often times mandatory. A lack of coordination can represent a hazard to people and equipment. When designing for coordination, fuses provide distinct advantages over other types of overcurrent protective devices.

To coordinate a circuit breaker protected system, it is generally necessary intentionally to delay the short circuit response of upstream breakers. Though coordination may be achieved, short circuit protection is compromised. The speed and consistency of response of fuses allows coordination without compromising component protection.

The terms coordination and selectivity are often used interchangeably. The term coordination should be used to describe a system as defined above, while two fuses are said to be selective

if the downstream fuse opens while the upstream fuse remains operable under **all** conditions of overcurrent. The term “discrimination” is synonymous with selectivity and is the preferred international term for this definition.

The word **all** is key. Fuse selectivity cannot be assured by comparing fuse time current curves alone. These curves stop at .01 second. Fuse performance under high fault conditions must also be evaluated. Fuse I<sup>2</sup>t is the best tool for assuring coordination under high fault current conditions. If the total clearing I<sup>2</sup>t of the downstream fuse is less than the melting I<sup>2</sup>t of the main upstream fuse, the fuses will be selective under high fault conditions.

To simplify presenting weighty I<sup>2</sup>t data, selectivity information can simply be found in selectivity ratio tables.

The ratios found in the following tables are conservative and are appropriate for all overcurrents up to 200,000 amperes RMS. In some cases smaller ratios than shown may be used. Consult your Ferraz Shawmut representative for specific recommendations.

### Fuse Selectivity Ratios - 600 and 480 Volt Applications Up to 200,000 RMS Symmetrical Amperes

BRANCH FUSE	RATIO*								
	MAIN FUSE								
	A4BQ	A4BY	A4BT	TRS	A6K	A6D	A4J	AJT	A6T
A4BQ	2:1	2:1	2:1	-	-	-	-	-	-
A4BY	-	2.5:1	2:1	-	-	-	-	-	-
A4BT	2.5:1	2.5:1	2:1	-	-	-	-	-	-
TRS	4:1	4:1	3:1	2:1	4:1	4:1	4:1	3:1	4.5:1
A6K	2:1	2:1	1.5:1	1.5:1	2:1	2:1	3:1	2:1	3.5:1
A6D	2:1	2:1	1.5:1	1.5:1	2:1	2:1	3:1	2:1	3.5:1
A4J	2:1	2:1	1.5:1	1.5:1	2:1	2:1	2:1	2:1	3:1
AJT	2:1**	2:1**	2:1	1.5:1	2:1	2:1	2.5:1	2:1	3.5:1
A6T	3:1	2.5:1	2:1	1.5:1	2:1	2:1	2:1	2:1	2.5:1

### Fuse Selectivity Ratios - 240 Volt Applications Up to 200,000 RMS Symmetrical Amperes

BRANCH FUSE	RATIO*								
	MAIN FUSE								
	A4BQ	A4BY	A4BT	TR	A2K	A2D	A4J	AJT	A3T
A4BQ	2:1	2:1	2:1	-	-	-	-	-	-
A4BY	-	2.5:1	2:1	-	-	-	-	-	-
A4BT	2.5:1	2.5:1	2:1	-	-	-	-	-	-
TR	4:1	4:1	4:1	1.5:1	4:1	3:1	4:1	3:1	5:1
A2K	2:1	2:1	1.5:1	1.5:1	2:1	1.5:1	2:1	1.5:1	3:1
A2D	2.5:1	2.5:1	2:1	1.5:1	2:1	1.5:1	2:1	2:1	3:1
A4J	2:1	2:1	1.5:1	1.5:1	2:1	1.5:1	2:1	2:1	3:1
AJT	2:1	2:1	2:1	1.5:1	2.5:1	2:1	2.5:1	2:1	3:1
A3T	1.5:1	1.5:1	1.5:1	1.5:1	1.5:1	1.5:1	1.5:1	1.5:1	2:1

\*These ratios apply to fuses rated 61-6000A.

\*\*Exception: For AJT450-600 use 2:1 on 480V only, 2.25:1 on 600V.



# APPLICATION INFORMATION

## SELECTIVITY BETWEEN TWO E-RATED FUSES IN SERIES

A selective system eliminates unnecessary power outages and costly downtime in the remainder of the system not directly affected by the fault condition. This results in significant savings and safety for the user.

In a properly designed selective system a branch fuse must open the circuit under fault conditions without damaging the main fuse. This is accomplished by making sure that the required Minimum Melting energy of the main fuse is greater than the Total Clearing energy required to “open” the branch fuse.

### Example:

In a 4160V system fed by a 200E main fuse (A055F1DORO-200E or equivalent), what is the maximum branch fuse allowable to maintain selectivity between the two?

From the table, the maximum E-rated branch fuse is 100E (A055F1DORO-100E or equivalent).

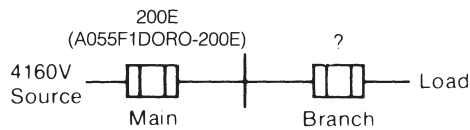

FUSE RATINGS			
2400, 4160 or 4800V SYSTEMS		6.9 thru 14.4KV SYSTEMS	
MAX. BRANCH	MIN. MAIN	MAX. BRANCH	MIN. MAIN
10E	20E	10E	20E
15E	25E	15E	25E
20E	40E	20E	30E
25E	40E	25E	50E
30E	50E	30E	65E
40E	65E	40E	65E
50E	80E	50E	80E
65E	125E	65E	125E
80E	150E	80E	150E
100E	200E	100E	200E
125E	250E	-	-
150E	250E	-	-
200E	400E	-	-
250E	400E	-	-
300E	450E	-	-
400E	-	-	-

**Note:** Selectivity is maintained on all overcurrents up to the maximum interrupting rating of the branch fuse.

**Recommended Fuses:** Ferraz Shawmut

CS-3: 5kV-A055F, 8kV-A825X\*, 15kV-A155F

CL-14: 5KV-A055C, A055B, 15KV-A155C

\*Consult factory for information on A825X series.

# APPLICATION INFORMATION

## SELECTIVITY OF E-RATED PRIMARY AND LOW VOLTAGE SECONDARY FUSES

Good design dictates that transformer secondary fuses should clear overcurrents before transformer primary fuses open. The following table shows the smallest primary fuse E rating which will be selective with a given secondary fuse.

Fuses are assumed to be Ferraz Shawmut Type CS-3 or CL-14 for primary, A4BY or A4BQ (Class L) for secondary 800 amperes and larger, Class J or Class RK1 for secondary 600 amperes and smaller.

The critical point for coordinating E-rated to low voltage fuses is in the 5-second to 10-second region of the fuse time current curves. This means that non-time delay secondary fuses will be selective with a lower E-rated primary fuse than will time delay secondary fuses. For this reason two E ratings are shown for most 600 ampere and smaller secondary fuses. The lower E rating will be selective with a non-time delay Class J or Class RK1. The higher E rating shown is required for selectivity with a time delay Class J or Class RK1.

The worst case condition for secondary fuse to primary fuse selectivity occurs when a line-to-line secondary fault develops on a delta-to-wye transformer. One of the primary fuses will see 116% of the turns ratio current. This worst case condition was assumed when the tables that follow were developed.

### Example 1:

With A6K400R (400A Class RK1) fuses as 480V secondary mains of a 13,800V/480V supply transformer, what is the minimum 13,800V primary fuse necessary for selectivity?

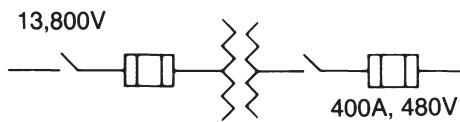

### Answer:

Since the A6K400R is not a time delay fuse it will coordinate with a 20E primary fuse (A155F1DORO-20E or equivalent).

### Example 2:

A 4160V distribution transformer supplies a 3000A, 208V main panel. What minimum 4160V primary fuse is needed to assure



selectivity?

### Answer:

A 200E primary fuse (A055F1DORO-200E or equivalent).

SEC. FUSE AMPERE RATING	MINIMUM PRIMARY FUSE RATING*				
	PRIMARY VOLTAGE				
	2400	4160	4800	6900	13,800
<b>480 Secondary</b>					
200	50E (80E)	30E (50E)	25E (40E)	20E (30E)	10E (15E)
400	100E (125E)	50E (80E)	50E (65E)	40E (50E)	20E (25E)
600	125E (200E)	100E (125E)	80E (125E)	65E (100E)	30E (50E)
800	250E	150E	125E	100E	50E
1000	300E	150E	150E	125E	50E
1200	350E	200E	200E	125E	65E
1600	500E	250E	250E	150E	100E
2000	600E	300E	300E	200E	100E
2500	-	450E	400E	-	125E
3000	-	500E	450E	-	150E
4000	-	-	600E	-	200E
5000	-	-	-	-	-
6000	-	-	-	-	-
<b>240V Secondary</b>					
200	25E (40E)	15E (25E)	15E (20E)	10E (15E)	10E
400	50E (80E)	30E (50E)	25E (40E)	20E (30E)	10E (15E)
600	80E (125E)	50E (65E)	40E (65E)	30E (40E)	15E (20E)
800	125E	80E	65E	50E	25E
1000	150E	100E	80E	65E	30E
1200	200E	125E	100E	65E	40E
1600	250E	125E	125E	100E	50E
2000	300E	150E	150E	125E	65E
2500	400E	250E	200E	150E	80E
3000	450E	250E	250E	150E	100E
4000	600E	400E	300E	200E	125E
5000	-	400E	400E	-	125E
6000	-	500E	450E	-	150E
<b>208V Secondary</b>					
200	20E (40E)	15E (25E)	10E (20E)	10E (15E)	10E
400	50E (80E)	25E (40E)	25E (40E)	15E (25E)	10E (15E)
600	65E (100E)	40E (65E)	40E (50E)	25E (40E)	15E (20E)
800	125E	65E	65E	50E	20E
1000	125E	80E	65E	50E	25E
1200	150E	100E	80E	65E	30E
1600	200E	125E	125E	80E	40E
2000	250E	150E	125E	100E	50E
2500	350E	200E	200E	125E	80E
3000	400E	200E	200E	150E	80E
4000	600E	300E	250E	200E	125E
5000	-	400E	350E	-	125E
6000	-	450E	400E	-	150E

\* ( ) indicates primary fuse rating when secondary fuse is time delay type

### Recommended Fuses:

Ferraz Shawmut Secondary, 200-600A - Class J (A4J or AJT) or RK1 (A2K or A2D 250V) (A6K or A6D 600V)

Secondary, 800-6000A - Class L (A4BY or A4BQ)

CS-3: 5kV-A055F, 8kV-A825X,\* 15kV-A155F

CL-14: 5kV-A055C, A055B, 15kV-A155C

\*Consult factory for information on A825X Series.



# APPLICATION INFORMATION

## SELECTIVITY BETWEEN E-RATED PRIMARY AND E-RATED SECONDARY FUSES

Some applications require selectivity between transformer secondary fuses and transformer primary fuses. The table below shows the smallest 15.5KV E-rated primary fuse which will be selective with a given E-rated secondary fuse. The table assures selectivity for Ferraz Shawmut Type CS-3 and CL-14 E-rated fuses under all current levels and under the worst case situation. The worst case situation exists when the following conditions occur simultaneously:

- Transformer is delta primary and wye secondary (see figure).
- A line-to-line secondary fault occurs.
- The fault current through a primary fuse is equal to the primary fuse 0.01 second melt current.

The worst case condition rarely occurs. In most cases selectivity will be maintained with a primary fuse one size smaller than shown in this table.

### Primary Fuse Ratings Selective With Secondary Ratings

SECONDARY FUSE RATING	MINIMUM 13.8KV PRIMARY FUSE RATING			
	SECONDARY VOLTAGE			
	2400	4160	4800	6900
10E	10E	10E	10E	15E
15E	10E	10E	15E	20E
20E	10E	15E	20E	20E
25E	10E	20E	25E	30E
30E	15E	25E	25E	40E
40E	20E	30E	40E	50E
50E	25E	40E	40E	65E
65E	30E	50E	65E	100E
80E	40E	65E	80E	100E
100E	50E	80E	100E	125E
125E	65E	100E	125E	150E
150E	80E	125E	125E	200E
200E	100E	150E	150E	-
250E	125E	200E	200E	-
300E	125E	-	-	-
400E	150E	-	-	-
450E	200E	-	-	-
600E	-	-	-	-

**Recommended Fuses:** Ferraz Shawmut CS-3: 5kV-A055F, 8kV-A825X,\* 15kV-A155F; CL-14: 5kV-A055C, A055B, 15kV-A155C  
 \*Consult factory for information on A825X Series.

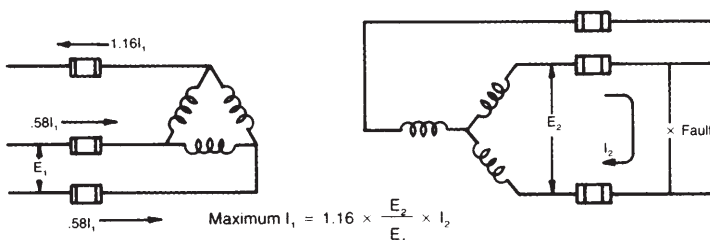

# APPLICATION INFORMATION

## SELECTIVITY BETWEEN E-RATED PRIMARY FUSES AND R-RATED SECONDARY MOTOR FUSES

Good design dictates that transformer secondary fuses shall clear overcurrents and not allow the primary fuse to open, thereby maintaining selectivity between the two.

With any system involving R-rated fuses, a contactor and overload relay must be employed to open on low overload currents. It is assumed in the table that the overload relay is properly selected and that the R-rated fuse is only required to open on overcurrents which are large enough for the fuse to open in times less than 20 seconds.

With the proper selection of the overload relay, selectivity is maintained throughout the full range of potential overcurrents. The contactor overload relay maintains selectivity with the E-rated primary fuse for low level overcurrents corresponding to opening times of 20 seconds and longer. The R-rated fuse maintains selectivity with the E-rated primary fuse on all higher level overcurrents corresponding to opening times of 20 seconds and shorter. Thus selectivity is maintained on all overcurrents to the maximum current interrupting rating published for the R-rated fuses.

## Selective Primary and Secondary Motor Fuse Ratings

SECONDARY FUSE R RATING	MINIMUM PRIMARY FUSE E RATING			
	PRIMARY VOLTAGE			
	4160V	4800V	6900V	13.8KV
<b>2400V Secondary System</b>				
2R	50E	50E	30E	15E
3R	80E	65E	50E	25E
4R	100E	100E	65E	30E
6R	125E	125E	100E	50E
9R	200E	200E	125E	65E
12R	250E	250E	150E	100E
18R	400E	350E	-	125E
24R	600E	450E	-	150E
36R	-	-	-	-
<b>4800V Secondary System</b>				
2R	-	-	65E	30E
3R	-	-	100E	50E
4R	-	-	125E	65E
6R	-	-	150E	100E
9R	-	-	-	125E
12R	-	-	-	150E
18R	-	-	-	-
24R	-	-	-	-
36R	-	-	-	-
<b>6900V Secondary System</b>				
2R	-	-	-	40E
3R	-	-	-	65E
4R	-	-	-	80E
6R	-	-	-	125E
9R	-	-	-	150E
12R	-	-	-	200E
18R	-	-	-	-

**Recommended Fuses:** Ferraz Shawmut  
 R-rated - A240R, A480R, A720R or equivalent  
 E-rated - CS-3: 5KV-A055F, 8KV-A825X,\* 15KV-A155F  
 CL-14: 5KV-A055C, A055B, 15KV-A155C  
 \* Consult factory for information on A825X Series.

### Example:

In a 13800V/2400V distribution system, what is the maximum size 2400V motor fuse which can be used if the distribution transformer primary is fused at 65E?

### Answer:

From the table, a 9R motor fuse (Ferraz Shawmut A240R9R) is the maximum size which can be used. If the 9R motor fuse opens on any overcurrent, it will not affect the 65E primary fuse, and selectivity is maintained.

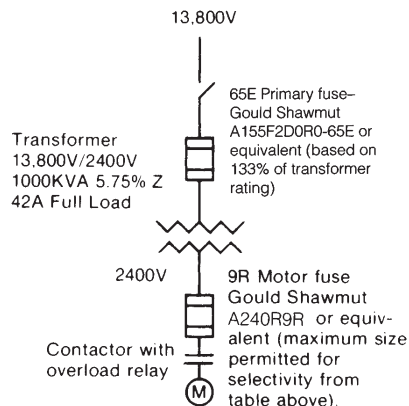

# APPLICATION INFORMATION

## SELECTIVITY BETWEEN E-RATED MAIN FUSE AND R-RATED MOTOR FUSE IN SERIES

Feeder fuses and motor fuses in series must be selective. Selectivity assures that the motor fuse only will open, and not the feeder fuse, thus eliminating power outages to the remainder of the branch circuits.

Selectivity is accomplished by assuring that the required minimum melting energy of the feeder fuse is greater than the total clearing energy required to open the motor fuse.

With any system involving R-rated fuses, a contactor and overload relay must be employed to open on low overhead currents. This table assumes that the overload relay is properly selected and that the R-rated fuse is only required to open on overcurrents which are large enough to open the fuse in 20 seconds or less.

Proper selection of the overload relay assures selectivity for all overcurrents. The contactor and relay in combination are selective with the E-rated fuse for low level overloads which correspond to opening times longer than 20 seconds. The R-rated fuse is selective with the E-rated fuse for higher level overcurrents up to the maximum interrupting rating of the R-rated fuse.

## Selective Main and Motor Fuse Ratings in Series

2400, 4160, 4800, 6900 or 7200V SYSTEMS	
MOTOR FUSE R RATING	MINIMUM MAIN FUSE E RATING
2R	80E
3R	125E
4R	150E
6R	200E
9R	300E
12R	400E
18R	600E
24R	-
36R	-

**Recommended Fuses:** Ferraz Shawmut  
 R-rated - A240R, A480R, A720R\* or equivalent  
 E-rated - CS-3: 5KV-A055F, 8KV-A825X,\* 15KV-A155F  
 CL-14: 5KV-A055C, A055B, 15KV-A155C  
 \*Consult factory for information on A825X Series.

### Example:

In a 4160V system, a motor requiring a 3R fuse is to be installed. What is the minimum E-rated feeder fuse required ahead of the motor?

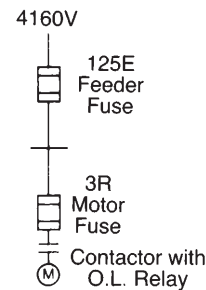

### Answer:

From the table, a 3R motor fuse (Ferraz Shawmut A480R3R-1) requires a minimum 125E distribution fuse (Ferraz Shawmut A055F1DORO-125E) upstream for proper selectivity. If the 3R motor fuse opens on any overcurrent, it will not affect the 125 E feeder fuse.

# APPLICATION INFORMATION

## QUICK THREE PHASE SHORT CIRCUIT CALCULATIONS

Short circuit current levels must be known before fuses or other equipment can be correctly applied. For fuses, unlike circuit breakers, there are four levels of interest. These are 10,000, 50,000, 100,000 and 200,000 RMS symmetrical amperes.

Rigorous determination of short circuit currents requires accurate reactance and resistance data for each power component from the utility generating station down to the point of the fault. It is time-consuming for a plant engineer to collect all this information and yet he is the one most affected by short circuit hazards.

There have been several approaches to “easy” short circuit calculations which have been cumbersome to be of practical use. The method described here is not new but it is the simplest of all approaches.

### Example 1:

What is the potential short circuit current at various points in a 480V, 3-phase system fed by a 1000KVA, 5.75%Z transformer? (Assume primary short circuit power to be 500MVA.)

In summary, each basic component of the industrial electrical distribution system is pre-assigned a *single* factor based on the impedance it adds to the system. For instance, a 1000KVA, 480 volt, 5.75%Z transformer has a factor of 4.80 obtained from Table A. This factor corresponds with 25,000 RMS short circuit amperes (directly read on Scale 1). Note: Factors change proportionally with transformer impedance. If this transformer were 5.00%Z, the factor would be  $5.00/5.75 \times 4.80 = 4.17$ .

Cable and bus factors are based on 100 foot lengths. Shorter or longer lengths have proportionately smaller or larger factors (i.e. 50' length = 1/2 factor; 200' length = 2 x factor). Basic component factors are listed on following pages in tables A through D.

To find the short circuit current at any point in the system, simply add the factors as they appear in the system from service entrance to fault point and read the available current on Scale 1.

### Example 2:

If the primary short circuit power were 50MVA (instead of 500MVA) in this same system, what would I<sub>sc</sub> be at the transformer? At the end of the bus duct run?

### Answer:

From the Primary MVA correction factor table A1, the factor for 50MVA (at 480V) is 1.74. The new factor at the transformer is then  $4.80 + 1.74 = 6.54$  and I<sub>sc</sub> is reduced to 18,000A (Scale 1). The new factor at the bus duct is  $9.21 + 1.74 = 10.95$  I<sub>sc</sub> = 11,000A (Scale 1).

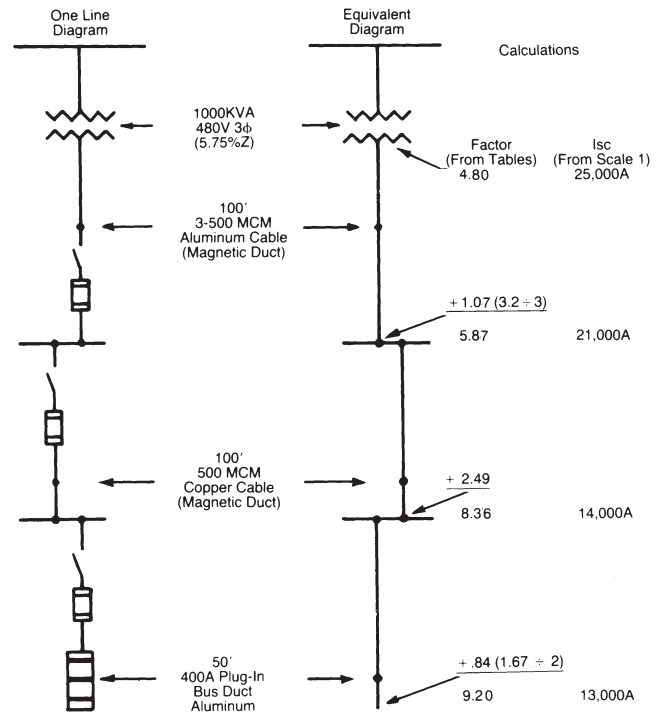

# APPLICATION INFORMATION

## QUICK THREE PHASE SHORT CIRCUIT CALCULATIONS (Continued)

### Component Factor Tables- Transformers

The transformer factors are based on available primary short circuit power of 500MVA and listed in Table A. For systems with other than 500MVA primary short circuit power, add the appropriate correction factors from Table A1 to the transformer factor found in Table A.

### A- Three Phase Transformer Factors

TRANSFORMER		FACTOR 3 PHASE VOLTAGE			
KVA	%Z	208	240	480	600
75	1.60	9.00	10.00	20.00	24.00
100	1.70	7.00	8.00	16.00	20.00
112.5	2.00	7.40	8.50	17.00	21.00
150	2.00	5.40	6.00	12.00	15.00
225	2.00	3.70	4.00	8.00	10.00
300	2.00	2.70	3.00	6.00	7.50
500	2.50	2.15	2.25	4.50	5.60
750	5.75	2.78	3.25	6.50	8.00
1000	5.75	2.24	2.40	4.80	6.00
1500	5.75	1.48	1.60	3.20	4.00
2000	5.75	NA	1.20	2.40	3.00
2500	5.75	NA	.95	1.91	2.40

**Notes:** 208 volt 3 $\phi$  transformer factors are calculated for 50% motor load. 240, 480 and 600 volt 3 $\phi$  transformer factors are calculated for 100% motor load. A phase-to-phase fault is .866 times the calculated 3-phase value.

### A1- Transformer Correction Factors

PRIMARY MVA	FACTOR			
	3 PHASE VOLTAGE			
	208	240	480	600
15	2.82	3.24	6.43	8.05
25	1.65	1.90	3.78	4.73
50	.78	.90	1.74	2.24
100	.34	.40	.80	1.00
150	.20	.23	.46	.58
250	.08	.10	.20	.25
Infinite	-.08	-.10	-.20	-.25

### A2- Factor for Second Three Phase Transformer in System

- Determine system factor at the second transformer primary.  
**Example:**  $I_{sc} @ 480V = 40,000A$ . Factor is 3.00 (from Scale 1).
- Adjust factor in proportion to voltage ratio of second transformer.  
**Example:** For 208V, factor changes to  $(208 \div 480) \times 3.00 = 1.30$
- Add factor for second 3 $\phi$  transformer.  
**Example:** Factor for 100KVA, 208V, 1.70%Z transformer is 7.00.  
Total Factor =  $7.00 + 1.30 = 8.30$   
( $I_{sc} = 14,500A$ )

### 3 $\phi$ to 3 $\phi$

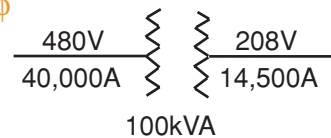

# APPLICATION INFORMATION

## QUICK THREE PHASE SHORT CIRCUIT CALCULATIONS (Continued)

### A3- Factors for Single Phase Transformer in Three Phase System

Transformer connections must be known before factor can be determined. See Figures A and B.

1. Determine system factor at 1 $\phi$  transformer primary, with 480V pri., 120/240V sec. (Figure A)

**Example:**  $I_{sc} @ 480V = 40,000$ , 3 $\phi$ . Factor is 3.00 (from Scale 1).

$$1\phi \text{ factor} = \frac{3\phi \text{ factor}}{.866} = \frac{3.00}{.866} = 3.46$$

2. Adjust factor in proportion to voltage ratio of 480/240V transformer.

**Example:** For 240V, 1 $\phi$  factor is  $(240 \div 480) 3.46 = 1.73$

3. Add factor for 1 $\phi$  transformer with Figure A connection.

**Example:** Factor for 100KVA, 120/240V, 3%Z transformer is:

- a. 120V--total factor =  $6.22 + 1.73 = 7.95$   
( $I_{sc} = 15,000A$ )
- b. 240V--total factor =  $8.64 + 1.73 = 10.37$   
( $I_{sc} = 11,600A$ )

### A3- Single Phase Transformer Factors

TRANSFORMER		FACTOR 1 PHASE VOLTAGE		
		120V	240V	120V
KVA	%Z	FIG. A	FIG. A	FIG. B
15	2.5	34.6	48.0	24.0
25	2.5	20.7	28.8	14.4
37.5	2.8	16.6	23.0	11.5
50	3.0	12.5	17.3	8.65
75	3.0	8.28	11.5	5.75
100	3.0	6.22	8.64	4.32
150	2.5	3.46	4.80	2.40
167	2.5	3.10	4.31	2.16
225	2.5	2.30	3.20	1.60
300	3.0	2.07	2.88	1.44
500	4.5	1.86	2.59	1.30

**Note:** Factor varies with %Z.

**Example:** 50KVA, 240V secondary with a 1.5%Z has a factor of  $(1.5\%Z + 3.0\%Z) \times 17.3 = 8.65$

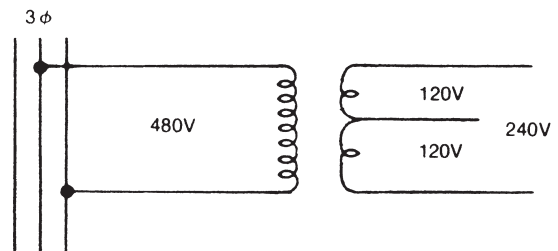

Fig. A

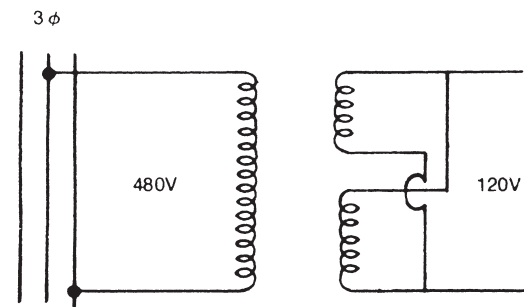

Fig. B



# APPLICATION INFORMATION

## QUICK THREE PHASE SHORT CIRCUIT CALCULATIONS (Continued)

### Component Factor Tables - Cables in Duct

#### B/B1- Copper Cables in Duct (Per 100')

CABLE SIZE	B-MAGNETIC DUCT				B1-NON-MAGNETIC DUCT			
	3 PHASE VOLTAGE				3 PHASE VOLTAGE			
	208	240	480	600	208	240	480	600
#8	79.00	68.00	34.00	27.00	78.00	67.60	33.80	27.10
6	50.00	43.00	22.00	17.50	47.90	41.50	20.70	16.60
4	32.00	28.00	14.00	11.15	30.70	26.70	13.30	10.70
2	21.00	18.00	9.00	7.23	19.90	17.20	8.61	6.89
1	17.50	15.00	7.40	5.91	16.20	14.00	7.07	5.60
1/0	14.00	12.20	6.10	4.85	13.20	11.40	5.70	4.57
2/0	11.80	10.20	5.10	4.05	10.60	9.21	4.60	3.68
3/0	9.80	8.50	4.27	3.43	8.87	7.59	3.85	3.08
4/0	8.40	7.30	3.67	2.94	7.57	6.55	3.28	2.62
250KCmil	7.70	6.70	3.37	2.70	6.86	5.95	2.97	2.38
300	7.00	6.10	3.04	2.44	5.75	4.98	2.49	1.98
350	6.60	5.70	2.85	2.28	5.36	4.64	2.32	1.86
400	6.20	5.40	2.70	2.16	5.09	4.41	2.20	1.75
500	5.80	5.00	2.49	2.00	4.66	4.04	2.02	1.62
600	5.50	4.80	2.40	1.91	4.29	3.72	1.86	1.49
750	5.20	4.50	2.26	1.80	4.05	3.51	1.76	1.41

#### C/C1- Aluminum Cables in Duct (Per 100')

CABLE SIZE	C-MAGNETIC DUCT				C1-NON-MAGNETIC DUCT			
	3 PHASE VOLTAGE				3 PHASE VOLTAGE			
	208	240	480	600	208	240	480	600
#8	129.00	112.00	56.00	45.00	129.75	112.45	56.20	45.00
6	83.00	72.00	36.00	29.00	80.00	69.10	34.60	27.70
4	53.00	46.00	23.00	18.50	51.10	44.20	22.10	17.70
2	35.00	30.00	15.00	12.00	33.00	25.70	14.30	11.40
1	28.00	24.00	12.00	9.50	26.30	22.80	11.40	9.12
1/0	21.50	18.50	9.70	7.70	21.20	18.40	9.20	7.36
2/0	18.50	16.00	8.00	6.40	17.00	14.70	7.34	5.87
3/0	15.00	13.00	6.50	5.20	13.80	12.00	6.02	4.79
4/0	12.50	11.00	5.50	4.40	11.50	9.95	4.98	3.99
250KCmil	11.10	9.60	4.80	3.85	10.10	8.72	4.36	3.49
300	9.90	8.60	4.30	3.42	8.13	7.04	3.52	2.81
350	8.60	7.40	3.70	3.00	7.49	6.50	3.07	2.45
400	8.30	7.20	3.60	2.90	6.87	5.95	2.98	2.38
500	7.40	6.40	3.20	2.60	6.12	5.31	2.66	2.13
600	7.20	6.20	3.10	2.44	5.30	4.59	2.29	1.83
750	6.50	5.60	2.80	2.22	4.85	4.20	2.10	1.69

**Note:** For parallel runs divide factor by number of conductors per phase.

**Example:** If factor for a single 500KCmil conductor is 2.49 then the factor for a run having 3-500KCmil per phase is  $2.49 \div 3 = .83$  (Example from Table B, 480 volts)

# APPLICATION INFORMATION

## QUICK THREE PHASE SHORT CIRCUIT CALCULATIONS (Continued)

$$I_{sc} = \frac{120,000}{\text{Total Factor}}$$

### Component Factor Tables - Bus Duct

#### D- Factors for Feeder\* Bus Duct (Per 100')

DUCT AMPERE RATING	FACTOR							
	3 PHASE VOLTAGE							
	COPPER				ALUMINUM			
	208	240	480	600	208	240	480	600
600	2.85	2.48	1.24	.99	2.54	2.19	1.10	.88
800	1.61	1.40	.70	.56	2.54	2.19	1.10	.88
1000	1.61	1.40	.70	.56	1.90	1.65	.82	.66
1200	1.21	1.06	.53	.42	1.60	1.36	.66	.54
1350	1.17	1.01	.51	.40	1.32	1.14	.57	.46
1600	1.03	.89	.45	.36	1.19	1.03	.52	.41
2000	.90	.78	.39	.31	.90	.77	.39	.31
2500	.63	.54	.27	.22	.70	.60	.30	.24
3000	.51	.44	.22	.18	.60	.52	.26	.21
4000	.37	.32	.16	.13	.43	.38	.19	.15
5000	.30	.26	.13	.10	--	--	--	--

\* These factors may be used with feeder duct manufactured by I-T-E, GE, Square D and Westinghouse.

#### D1- Factors for Plug-In\*\* Bus Duct (Per 100')

DUCT AMPERE RATING	FACTOR							
	3 PHASE VOLTAGE							
	COPPER				ALUMINUM			
	208	240	480	600	208	240	480	600
400	2.53	2.18	1.09	.89	3.88	3.34	1.67	1.36
600	2.53	2.18	1.09	.89	2.41	2.07	1.04	.84
800	1.87	1.61	.81	.66	2.41	2.07	1.04	.84
1000	1.87	1.61	.81	.66	1.69	1.45	.73	.59
1200	1.47	1.26	.63	.51	1.43	1.22	.61	.50
1350	1.26	1.08	.54	.44	1.30	1.12	.56	.45
1600	.91	.78	.39	.32	1.09	.94	.47	.38
2000	.79	.68	.34	.28	.89	.77	.38	.31
2500	.61	.52	.26	.21	.66	.57	.28	.23
3000	.48	.42	.21	.17	.59	.51	.25	.21
4000	.43	.37	.18	.15	.46	.40	.20	.16
5000	.38	.33	.16	.13	.35	.30	.15	.12

\*\* These factors may be used with plug-in duct manufactured by GE, Square D and Westinghouse.

### SHORT CIRCUIT CURRENT

TOTAL FACTOR | I<sub>sc</sub> - RMS AMPERES

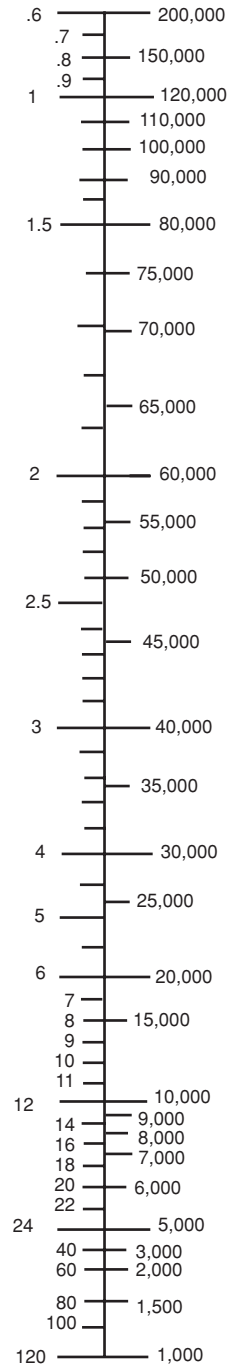

SCALE 1



# APPLICATION INFORMATION

## PROPERTIES OF MATERIALS

### FUSE BLOCKS, FUSE HOLDERS, POWER DISTRIBUTION BLOCKS, FUSES & ACCESSORIES

PROPERTY	UNITS	ASTM TEST	PHENOLIC	POLYCARBONATE	POLYAMIDE	POLYBUTYLENE TERPHTHALATE	POLYSULFONE COPOLYMER	POLYPHTALAMIDE
Specific Gravity	-	D792	1.4	1.21	1.36	1.6	1.52	1.71
IZOD	ft-lb/in	D256	0.29	4-6	3.2	1.2	1.8	1.5
Flexural Strength	psi	D790	11,000	13,200	38,000	27,000	26,900	37,300
Flexural Modulus	psi	D790	1.1 x 10 <sup>6</sup>	325,000	1.25 x 10 <sup>6</sup>	1.1 x 10 <sup>6</sup>	1.4 x 10 <sup>6</sup>	1.9 x 10 <sup>6</sup>
Tensile Strength	psi	D638	7,000	9,000	25,000	17,000	17,600	26,000
Compressive Strength	psi	D695	28,800	12,500	34,000	18,000	-	-
Water Absorption	24 hrs %	D570	0.45	0.15	1.3	0.06	0.1	0.18
Hardness	Rockwell	D785	M-110	M-85	R-105	R-119	-	-
Dielectric Strength								
60 hertz, 25°C, s/t	vpm	-	300	425	435	460	500	460
60 hertz, 25°C, s/s	vpm	-	250	425	-	460	-	-
Dielectric Constant								
60 hertz-dry	-	D150	5.96	3.01	-	-	-	-
1 Mhertz-dry	-	D150	4.9	2.96	3.6	3.7	3.8	4.9
Volume Resistivity	ohm-cm	D257	50 x 10 <sup>6</sup>	>10 <sup>16</sup>	10 <sup>16</sup>	>3.4 x 10 <sup>16</sup>	>10 <sup>16</sup>	3 x 10 <sup>16</sup>
Heat Deflection (°F @ 264 psi)	°F	D648	320	270	410	400	330	523
Flammability (UL 94)	-	-	94 V-0	94 V-0	94 V-0	94 V-0	94 V-0	94 V-0
Relative Thermal Index (RTI) (UL746B)								
Electrical	°C	-	150	125	150	130	150	140
Mechanical without impact	°C	-	150	125	140	140	150	130

Note: Above data represents approximate values and are for reference only.

# APPLICATION INFORMATION

## Comparative Data of Stranded Copper and Aluminum Cables

SIZE AWG kcMIL	AREA	
	Circular Mils	Square Millimeters
30	100.5	0.051
28	159.8	0.081
26	254.1	0.123
24	404.0	0.205
22	642.4	0.326
20	1022	0.518
18	1620	0.823
16	2580	1.31
14	4110	2.08
12	6530	3.31
10	10380	5.26
8	16510	8.37
6	26240	13.3
4	41740	21.2
3	52620	26.7
2	66360	33.6
1	83690	42.4
1/0	105600	53.5
2/0	133100	67.4
3/0	167800	85.0
4/0	211600	107
250	-	127
300	-	152
350	-	177
400	-	203
500	-	253
600	-	304
700	-	355
750	-	380
800	-	405
900	-	456
1000	-	507
1250	-	634
1500	-	760
1750	-	887
2000	-	1014

## Recommended Tightening Torque for Bolt-On and Stud Mounted Fuses

### English Sizes

THREAD SIZE	TIGHTENING TORQUE	
	ft.-lbs	in-lbs
1/4-20	4	50
5/16-18	7.5	90
3/8-16	13	160
3/8-24	15	180
1/2-13	30	360
1/2-20	31	375

### Metric Sizes

THREAD SIZE	TIGHTENING TORQUE	
	newton-meters	in-lbs
M6	6	53
M8	13	115
M10	26	230
M12	45	398

## Small Ampere Rating Equivalents

FRACTION	DECIMAL	MILLIAMPS
1/100	0.0100	10
1/64	0.0156	15
1/32	0.03125	31
4/100	0.0400	40
5/100(1/20)	0.0500	50
1/16	0.0625	62.5
8/100	0.0800	80
1/8	0.1250	125
15/100	0.150	150
16/100	0.160	160
3/10	0.3000	300
315/1000	0.3150	315
3/8	0.3750	375
4/10	0.4000	400
1/2	0.5000	500
6/10	0.6000	600
630/1000	0.6300	630
7/10	0.7000	700
3/4	0.7500	750
8/10	0.8000	800
9/10	0.9000	900
1	1.000	1000



# APPLICATION INFORMATION

## RULES FOR EQUIPMENT SHORT CIRCUIT RATING

The National Electric Code (1999) states:

### 110-9. Interrupting Rating

“Equipment intended to interrupt current at fault levels shall have an interrupting rating sufficient for the nominal circuit voltage and the current that is available at the line terminals of the equipment. Equipment intended to interrupt current at other than fault levels shall have an interrupting rating at nominal circuit voltage sufficient for the current that must be interrupted.”

Enclosed fusible switches whether for individual wall mounting or in equipment assemblies, are “equipment intended to interrupt current”. With this in mind, both the switch and the fuse must be adequately rated to satisfy code requirements.

The fuse must have an interrupting rating greater than the short circuit current available at the line terminals of the switch. The switch must have a short circuit current withstand rating greater than the short circuit current available at the line terminals of the switch.

UL98 “Enclosed and Dead-Front Switches” requires that Listed switches be tested with fuses to establish the short circuit current withstand rating of the switch. The switch is then required to be marked with its withstand rating, the appropriate UL fuse class and maximum circuit voltage.

## FERRAZ SHAWMUT INSTRUCTIONAL VIDEOS

### **Misapplication** (8 minutes)

An early film which dramatically shows the hazards of substituting the wrong fuse at an industrial plant.

### **Circuit Protection For The Future, Today** (9 minutes)

Shows a comparison of fuses and circuit breakers protecting electrical equipment found in typical industrial plants.

### **AJT/IEC Contractor Protection** (10 minutes)

Demonstrates the difference between the protection requirements of North American and European motor control components.

### **A-T 2000** (12 minutes)

Shows the importance of high current limitation and introduces the concept of “No Damage” protection.

## 10 REASONS FOR USING CURRENT-LIMITING FUSES

### ➤ **RELIABILITY**

No moving parts to wear or become contaminated by dust, oil or corrosion.

### ➤ **LONG LIFE**

The speed of response of a fuse will not change or slow down as the fuse ages. In other words, the fuse’s ability to provide protection is not adversely affected by the passage of time.

### ➤ **MINIMAL MAINTENANCE**

Fuses do not require periodic recalibration as do electro mechanical overcurrent protective devices.

### ➤ **COMPONENT PROTECTION**

The current limiting action of a fuse minimizes or eliminates component damage.

### ➤ **NORTH AMERICAN STANDARDS**

Tri-national Standards specify fuse performance and maximum allowable fuse  $I_p$  and  $I^2t$  let-thru values.

### ➤ **SELECTIVITY**

Fuses may be easily coordinated to provide selectivity under both overload and short circuit conditions.

### ➤ **HIGH INTERRUPTING RATING**

You don’t pay a premium for high interrupting capacity. Most low voltage current limiting fuses have a 200,000 ampere interrupting rating.

### ➤ **COST EFFECTIVE**

Fuses are generally the most cost effective means of providing overcurrent protection. This is especially true where high fault currents exist or where small components need protection.

### ➤ **EXTENDED PROTECTION**

Devices with low interrupting ratings are often rendered obsolete by service upgrades or increases in available fault current. Non-fused systems may need expensive system upgrades to maintain system safety.

### ➤ **SAFETY**

Overcurrent protective devices which operate are often reset without first investigating to find the cause of opening. Electro-mechanical devices which have opened high level faults may not have the reserve capacity to open a 2nd or 3rd fault safely. When a fuse opens it is replaced with a new fuse, thus protection is not degraded by previous faults.

# APPLICATION INFORMATION



## SUGGESTED FUSE SPECIFICATIONS

### 1.0 General

The electrical contractor shall furnish and install a complete set of fuses for all fusible equipment on the job as specified by the electrical drawings. Final tests and inspections shall be made prior to energizing the equipment. This shall include tightening all electrical connections and inspecting all ground conductors. Fuses shall be as follows:

### 2.0 Mains, Feeders and Branch Circuits

**A.** Circuits 601 to 6000 amperes shall be protected by current-limiting Ferraz Shawmut Amp-Trap 2000 Class L time-delay **A4BQ** fuses. Fuses shall be time-delay and shall hold 500% of rated current for a minimum of 4 seconds, clear 20 times rated current in .01 second or less and be UL Listed and CSA Certified with an interrupting rating of 200,000 amperes rms symmetrical.

**B.** Circuits 600 amperes or less shall be protected by current-limiting Ferraz Shawmut Amp-Trap 2000 Class RK1 time-delay **A2D** (250V) or **A6D** (600V) or Class J time-delay **AJT** fuses. Fuses shall hold 500% of rated current for a minimum of 10 seconds (30A, 250V Class RK1 case size shall be a minimum of 8 seconds) and shall be UL Listed and CSA Certified with an interrupting rating of 200,000 amperes rms symmetrical.

### C. Motor Protection

All individual motor circuits shall be protected by Ferraz Shawmut Amp-Trap 2000 Class RK1, Class J or Class L time-delay fuses as follows:

Circuits up to 480A: Class RK1 - **A2D** (250V) or **A6D**(600V)  
Class J - **AJT**

Circuits over 480A: Class L - **A4BQ**

Fuse sizes for motor protection shall be chosen from tables published by Ferraz Shawmut for the appropriate fuse. Heavy load and maximum fuse ratings are also shown for applications where typical ratings are not sufficient for the starting current of the motor.

### D. Motor Controllers

Motor controllers shall be protected from short circuits by Ferraz Shawmut Amp-Trap 2000 time-delay fuses. For Type 2 protection of motor controllers, fuses shall be chosen in accordance with motor control manufacturers' published recommendations, based on Type 2 test results. The fuses shall be Class **RK1 A2D** (250V) or **A6D** (600V) or Class J **AJT** or Class CC **ATDR** (600V).

**E.** Circuit breakers and circuit breaker panels shall be protected by Ferraz Shawmut Amp-Trap 2000 fuses Class RK1 (**A2D** or **A6D**), Class J (**AJT**) or Class L (**A4BQ**) chosen in accordance with tested UL Series-connected combinations published in the current yellow UL Recognized Component Directory.

**F.** Lighting and control circuits in the connected combinations shown up to 600VAC shall be protected by Ferraz Shawmut Amp-Trap 2000 Class CC time-delay **ATQR** or **ATDR** fuses, sized according to the electrical drawings.

### 3.0 Spares

Spare fuses amounting to 10% (minimum three) of each type and rating shall be supplied by the electrical contractor. These shall be turned over to the owner upon project completion. Fuses shall be contained and cataloged within the appropriate number of spare fuse cabinets (no less than one). Spare fuse cabinets shall be equipped with a key lock handle, be dedicated for storage of spare fuses and shall be **GSFC**, as supplied by Ferraz Shawmut.

### 4.0 Execution

**A.** Fuses shall not be installed until equipment is to be energized. All fuses shall be of the same manufacturer to assure selective coordination.

**B.** As-installed drawings shall be submitted to the engineer after completion of the job.

**C.** All fusible equipment rated 600 amperes or less shall be equipped with fuse clips to accept Class RK1 or Class J fuses as noted in the specifications.

### 5.0 Substitution

Fuse sizes indicated on drawings are based on Ferraz Shawmut Amp-Trap 2000 fuse current-limiting performance and selectivity ratios. Alternative submittals to furnish materials other than those specified, shall be submitted to the engineer in writing two weeks prior to bid date, along with a short circuit and selective coordination study.

