

REV	DATE	ECO	DESCRIPTION	BY	CK	APP
-	3-9-99	N/A	INITIAL RELEASE	CRP	N/A	N/A
A	4-7-99	N/A	ADDED TOLERANCES (3 PLACES)	CRP	N/A	N/A

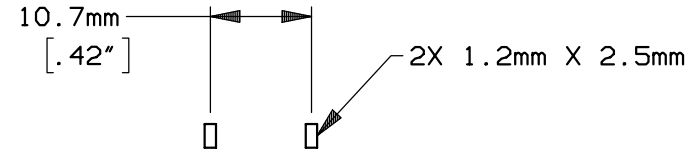

MOUNTING HOLE PATTERN

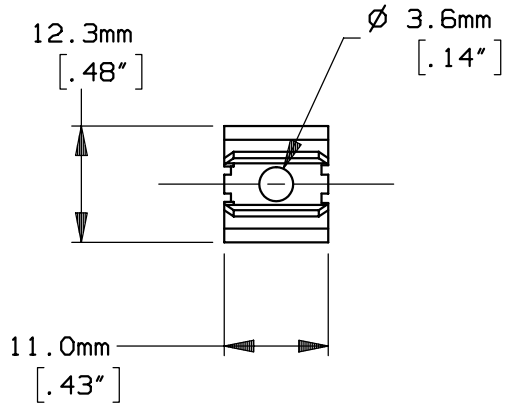
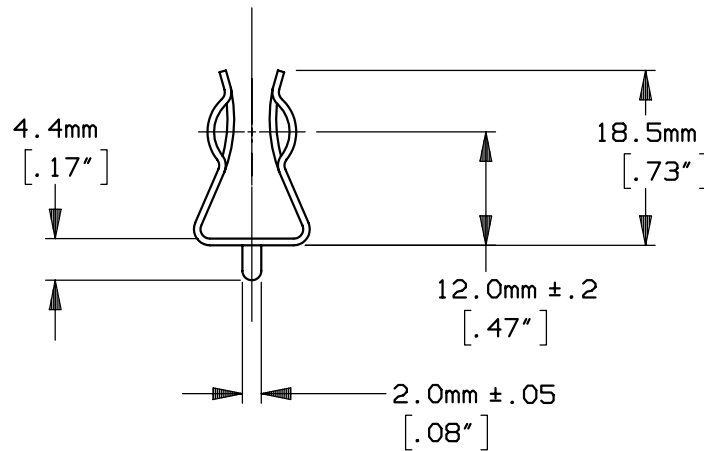
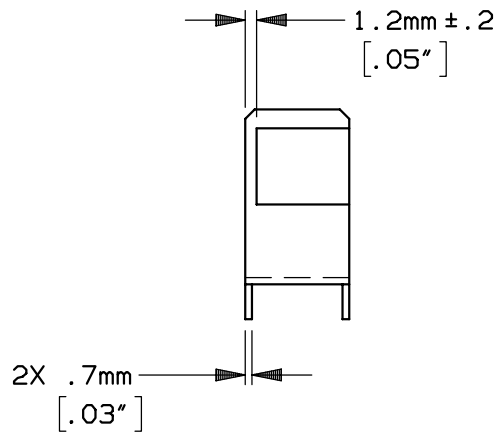

1. MATERIAL: SPRING BRASS, TIN PLATED



FERRAZ SHAWMUT INC.
374 MERRIMAC STREET
NEWBURYPORT, MA 01950

10mm (13/32") PC MOUNT FUSE CLIP

OUTLINE DIMENSIONS
NOT TO BE USED FOR PRODUCTION

PRODUCT MANAGER

DESIGN ENGINEER

SIGN:
DATE:

SIGN:
DATE:

CAT. NO. SDC7

700424